



**FALLBROOK PUBLIC UTILITY DISTRICT  
BOARD OF DIRECTORS  
REGULAR BOARD MEETING / PUBLIC HEARING**

**AGENDA**

**PURSUANT TO WAIVERS TO CERTAIN BROWN ACT PROVISIONS UNDER EXECUTIVE ORDERS ISSUED BY GOVERNOR NEWSOM RELATED TO THE COVID-19 STATE OF EMERGENCY THIS MEETING WILL BE CONDUCTED VIA WEB AND TELECONFERENCE USING THE BELOW INFORMATION, AND THERE WILL BE NO PHYSICAL LOCATION FROM WHICH MEMBERS OF THE PUBLIC MAY PARTICIPATE. INSTEAD MEMBERS OF THE PUBLIC ARE ENCOURAGED TO PARTICIPATE IN THE BOARD MEETING VIA WEB CONFERENCE USING THE BELOW CALL-IN AND WEBLINK INFORMATION.**

<https://zoom.us/j/99035843575?pwd=MVBHd2JCYzAwTDZxODh5eEUzUm01dz09>

MEETING ID 990 3584 3575  
AUDIO CALL-IN 1-669-900-9128  
AUDIO PASSCODE 742881

**PUBLIC COMMENTS:** Members of the public may submit public comments and comments on agenda items in one of the following ways:

**SUBMIT COMMENTS BEFORE THE MEETING:**

- By emailing to our Board Secretary at [leckert@fpud.com](mailto:leckert@fpud.com)
- By mailing to the District Offices at 990 E. Mission Rd., Fallbrook, CA 92028
- By depositing them in the District's Payment Drop Box located at 990 E. Mission Rd., Fallbrook, CA 92028

All comments submitted before the meeting by whatever means must be received at least 1 hour in advance of the meeting. All comments will be read to the Board during the appropriate portion of the meeting. Please keep any written comments to 3 minutes.

**MAKE COMMENTS DURING THE MEETING:** The Board President will inquire prior to Board discussion if there are any comments from the public on each item.

- Via Zoom Webinar go to the "Participants List," hover over your name and click on "raise hand." This will notify the moderator that you wish to speak during oral communication or during a specific item on the agenda.
- Via phone, you can raise your hand by pressing \*9 to notify the moderator that you wish to speak during the current item.

**THESE PUBLIC COMMENT PROCEDURES SUPERSEDE THE DISTRICT'S STANDARD PUBLIC COMMENT POLICIES AND PROCEDURES TO THE CONTRARY.**

**MONDAY, FEBRUARY 22, 2021  
4:00 P.M.**

**FALLBROOK PUBLIC UTILITY DISTRICT  
990 E. MISSION RD., FALLBROOK, CA 92028  
PHONE: (760) 728-1125**

*If you have a disability and need an accommodation to participate in the meeting, please call the Secretary at (760) 999-2704 for assistance so the necessary arrangements can be made.*

**I. PRELIMINARY FUNCTIONS**

CALL TO ORDER / ROLL CALL / ESTABLISH A QUORUM

PLEDGE OF ALLEGIANCE

ADDITIONS TO AGENDA PER GC § 54954.2(b)

APPROVAL OF AGENDA

PUBLIC COMMENT

*Members of the public are invited to address the Board of Directors on any item that is within the subject matter jurisdiction of the legislative body. The Board President may limit comments to three (3) minutes.*

- A. RECOGNITION AND COMMENDATION OF STUDENT ARTWORK AND 4<sup>TH</sup> GRADE TEACHER
- B. EMPLOYEE OF THE QUARTER FEBRUARY 2021
  - 1. Christian Hernandez
- C. MANAGER'S AWARD
  - 1. Mickey Case
- D. EMPLOYEE ANNOUNCEMENTS
  - 1. Jacob Hyink

**II. CONSENT CALENDAR----- (ITEMS E – H)**

*All items appearing on the Consent Calendar may be disposed of by a single motion. Items shall be removed from the Consent Calendar if any member of the Board of Directors or the public requests removal prior to a vote on a motion to approve the items. Such items shall be considered separately for action by the Board.*

- E. CONSIDER APPROVAL OF MINUTES
  - 1. January 25, 2021 Regular Board Meeting

*Recommendation: The Board approve the minutes of the aforementioned meeting of the Board of Directors of the Fallbrook Public Utility District.*

- F. CONSIDER CLAIM FOR INUNDATION OF WATER ONTO REAL PROPERTY

*Recommendation: The aggregate cost of the claims related to the incident will exceed the District retrospective allocation point of \$25,000. Staff recommends rejection of this claim, and any and all claims resulting from*

*this incident, and to forward all claims for this incident to ACWA/JPIA for resolution.*

- G. CONSIDER EASEMENT QUITCLAIM FOR 420 WEST DOUGHERTY STREET

Recommendation: *That the Board authorize to quitclaim the easement recorded as Document No. 2008-0306324.*

- H. CONSIDER LETTER OF SUPPORT FOR HR 535/S.91 (SPECIAL DISTRICTS PROVIDE ESSENTIAL SERVICES ACT) & AB 361 (RIVAS) – REMOTE MEETINGS DURING DECLARED EMERGENCIES.

Recommendation: *The Board authorize letters supporting HR 535/S.91 (Special Districts Provide Essential Services Act) & AB 361 (Rivas) – Remote Meetings During Declared Emergencies and direct staff to distribute the letter of support to the District’s legislators.*

**III. INFORMATION -----(ITEMS I – J)**

- I. ENGINEERING AND OPERATIONS KEY PERFORMANCE INDICATORS

Presented by: *Aaron Cook, Engineering Manager*

- J. RECYCLED WATER PROGRAM UPDATE

Presented by: *Jack Bebee, General Manager*

**IV. ACTION / DISCUSSION CALENDAR -----(ITEMS K – O)**

- K. CONSIDER THE FALLBROOK VILLAGE ASSOCIATION AS A COMMUNITY SERVICE WATER USER (VINCE ROSS SQUARE)

Recommendation: *Staff supports the Board’s direction. If approved, staff will provide an update on water usage at the end of each fiscal year*

- L. CONSIDER AUTHORIZATION FOR ADDITIONAL DEPOSIT TO SAN DIEGO LOCAL AGENCY FORMATION COMMISSION

Recommendation: *That the Board authorize the General Manager to provide an additional deposit to SDLAFCO of \$50,000.*

- M. CONSIDER SMRCUP GAC INSTALLATION CHANGE ORDER

Recommendation: *That the Board approve the change order for Filanc-Alberici to complete the additional work at a cost of \$3,389,801.*

- N. CONSIDER ADOPTION OF RESOLUTION NO. 5006, UPDATING THE ADMINISTRATIVE CODE TABLE OF CONTENTS, RENUMBERING OF EXISTING ARTICLES TO CREATE A SEQUENTIAL ORDER, AND UPDATING INTERNAL SECTION CROSS-REFERENCES AS NECESSARY

*Recommendation:* That the Board adopt Resolution No. 5006, amending the Administrative Code Table of Contents, and renumbering Administrative Code Articles to create a sequential order, and update internal section cross-references as necessary.

- O. CONSIDER REQUEST FOR APPROVAL TO PURCHASE ONE BOOM TRUCK CRANE

*Recommendation:* The Board approve the purchase of one boom truck crane from Velocity Truck Centers in the amount of \$314,627.03.

**V. PUBLIC HEARING -----(ITEM P)**

- P. POTENTIAL INCREASE IN COMPENSATION FOR MEMBERS OF THE BOARD OF DIRECTORS (ADMINISTRATIVE CODE SECTION 2.12); ORDINANCE NO. 349

*Recommendation:* Hold the public hearing and consider adoption of Ordinance No. 349, to increase Board compensation from \$110.25 to \$115.76 for each day's service to the District and to update Section 2.12 of the District's Administrative Code to reflect the updated amount.

**VI. ORAL/WRITTEN REPORTS----- (ITEMS 1-8)**

1. General Counsel
2. SDCWA Representative Report
3. General Manager
  - a. Engineering and Operations Report
4. Assistant General Manager/Chief Financial Officer
  - a. Financial Summary Report
  - b. Treasurer's Report
  - c. Budget Status Report
  - d. Warrant List
5. Public Affairs Specialist
6. Notice of Approval of Per Diem for Meetings Attended
7. Director Comments/Reports on Meetings Attended
8. Miscellaneous

**VII. CLOSED SESSION-----**(ITEMS 1-2)****

1. CONFERENCE WITH LEGAL COUNSEL – ANTICIPATED LITIGATION SIGNIFICANT EXPOSURE TO LITIGATION PER GC § 54956.9 (d)(2):

*One (1) Potential Case (Claim filed by George Acquavella)*

2. CONFERENCE WITH LEGAL COUNSEL – EXISTING LITIGATION PURSUANT TO GOVERNMENT CODE SECTION 54956.9 (d)(1):

*Name of Case: Todd Lange v. Fallbrook Public Utility District, San Diego Co. Sup. Ct. (North County) Case No 37-2020-00046705-CU-PT-NC*

RECONVENE TO OPEN SESSION

REPORT FROM CLOSED SESSION (*As necessary*)

**VIII. ADJOURNMENT OF MEETING**

\* \* \* \* \*

**DECLARATION OF POSTING**

I, Lauren Eckert, Executive Assistant/Board Secretary of the Fallbrook Public Utility District, do hereby declare that I posted a copy of the foregoing agenda in the glass case at the entrance of the District Office located at 990 East Mission Road, Fallbrook, California, at least 72 hours prior to the meeting in accordance with Government Code § 54954.2(a).

I, Lauren Eckert, further declare under penalty of perjury and under the laws of the State of California that the foregoing is true and correct.

February 17, 2021  
Dated / Fallbrook, CA

/s/ Lauren Eckert  
Executive Assistant/Board Secretary

**M E M O**

**TO:** Board of Directors, Management Staff  
**FROM:** Noelle Denke, Public Affairs Specialist  
**DATE:** February 22, 2021  
**SUBJECT:** Recognition and Commendation of Student Artwork and 4<sup>th</sup> Grade Teacher

---

Purpose

To commend 16 student artists in the 4<sup>th</sup> grade, and their teacher Guillermo Acevedo, who submitted artwork for the 2021 “Be Water Smart” calendar.

Summary

With the COVID-19 pandemic and students spending very little time in the classroom, learning almost exclusively online from home, the annual calendar contest was a significant challenge this year. Classroom presentations from FPUD’s public affairs representative, Noelle Denke, were not an option. The presentations play an important part of the contest, however, as they teach the water cycle and conservation, and generate excitement and participation for the “Be Water Smart” poster contest. Teachers often encourage or require their students to enter, typically generating about 250 entries.

Since teachers are undoubtedly struggling with distance learning, the contest was pushed to the bottom of their priority list. However, one teacher, Guillermo Acevedo, a 4<sup>th</sup> grade teacher at Live Oak Elementary, made it a priority and 16 of his students submitted entries. All are worthy of inclusion in the 2021 Be Water Smart calendar. This is the 16<sup>th</sup> year he has encouraged his students to enter the contest. This year, he was the only teacher in the district to get his students to participate.

Mr. Acevedo and his students are to be commended. He worked with Mrs. Denke to have the contest deadline extended. A video was also made explaining the contest. Students were asked to draw a picture of how to be water smart, or smart ways to conserve water so there’s enough for all living things, or water smart ways to prevent water pollution. This is the first time the calendar will be made up of entries from just one class. It is also the first time FPUD will be producing an 18-month calendar.

The winners will receive gift cards and some items with the FPUD logo on them: a Frisbee, water bottle and some school supplies. They will also have their artwork specially matted and framed. Additionally, the top three will win a T-shirt with their artwork printed on it.

Their artwork will be displayed in the FPUD boardroom hallway for one year. It will also be used monthly in social media posts.

The winners are: 1<sup>st</sup> place: Jaqueline Rosas, 2<sup>nd</sup> place: Camila Palma, 3<sup>rd</sup> place: Liam Rafalski; remaining winners are Noah Varela, Annabella Cunningham, Ewny Sebastian, Bruce Byrd, Edgar Campos, Jocelyn Garcia, Adrian Calderon, Brandon Garcia, Tobin Marshall, Ryder Orozco, Natalie Mendoza, Evan Pellanda and Deisy Ramos.

**M E M O**

**TO:** Board of Directors  
**FROM:** Jack Bebee, General Manager  
**DATE:** February 22, 2021  
**SUBJECT:** February 2021 Employee of the Quarter

---

Lauren Eckert, November 2020 Employee of the Quarter, chose Christian Hernandez as the February 2021 Employee of the Quarter for the following reasons:

*“Christian Hernandez has recently, received positive feedback on multiple occasions. He was also recently recognized for exemplary work performance and for being an outstanding representative of the District, when he received a Manager’s Award at the December Board Meeting.”*

Christian received a Certificate of Appreciation and chose a gift valued at \$150. Additionally, Christian will have lunch with the General Manager, a member of the Board of Directors, and the previous Employee of the Quarter once COVID-19 restrictions permit.

MEMO

**TO:** Board of Directors  
**FROM:** Dave Shank, Assistant General Manager/CFO  
**DATE:** February 22, 2021  
**SUBJECT:** Manager's Award Recipient

---

Description

To recognize Manager's Award recipient Mickey Case.

Purpose

Over the past year, Mickey's expertise and ability to quickly pivot office staff to working remotely has allowed the District to seamlessly continue its day-to-day administrative operations. We appreciate his hard work, and we continue to appreciate his patience when addressing all of our technical issues that need to be resolved.

Mickey will receive a \$25 gift card.

Budgetary Impact

Approximately \$25 will be expensed under the Human Resources Staff Development budget for the 2020-21 fiscal year.

Recommended Action

This item is for information only; no Board action is required.



**This page intentionally left blank.**

**M E M O**

**TO:** Board of Directors  
**FROM:** Lauren Eckert, Executive Assistant/Board Secretary  
**DATE:** February 22, 2021  
**SUBJECT:** Approval of Minutes

---

Recommended Action

That the Board approve the minutes of the following meeting of the Board of Directors of the Fallbrook Public Utility District:

1. January 25, 2021 Regular Meeting



**FALLBROOK PUBLIC UTILITY DISTRICT  
BOARD OF DIRECTORS  
REGULAR BOARD MEETING**

**MINUTES**

**MONDAY, JANUARY 25, 2021  
4:00 P.M.**

**FALLBROOK PUBLIC UTILITY DISTRICT  
990 E. MISSION RD., FALLBROOK, CA 92028  
PHONE: (760) 728-1125**

*If you have a disability and need an accommodation to participate in the meeting, please call the Secretary at (760) 999-2704 for assistance so the necessary arrangements can be made.*

**I. PRELIMINARY FUNCTIONS**

**CALL TO ORDER / ROLL CALL / ESTABLISH A QUORUM**

Vice President Baxter called the January Regular Meeting of the Board of Directors of the Fallbrook Public Utility District to order at 4:02 p.m.

Vice President Baxter announced, for the record, that this meeting was conducted by teleconference using the call-in and web link on the agenda, pursuant to the Brown Act waivers to certain provisions under the Governor's Executive Order in response to the COVID-19 State of Emergency.

Vice President Baxter also announced the agenda provided notice that members of the public were encouraged to participate in the Board meeting via teleconference using the call-in and web link information, and that members of the public could have also emailed public comments and comments on agenda items in advance of the meeting by mailing them to the District, dropping them in the District's payment drop box, or emailing them to the Board Secretary. Any such written comments would be read on to the record at the appropriate portion of the meeting – up to a limit of three (3) minutes per comment. These instructions supersede the District's normal public comment procedures

Vice President Baxter reported that President DeMeo was absent from the meeting.

A quorum was established, and attendance was as follows:

**Board of Directors**

**Present:** Dave Baxter, Member/Vice President  
Ken Endter, Member  
Don McDougal, Member  
Charley Wolk, Member

Absent: Jennifer DeMeo, President

General Counsel/District Staff

Present: Jack Bebee, General Manager  
Paul de Sousa, General Counsel  
Dave Shank, Assistant General Manager/CFO  
Jason Cavender, Operations Manager  
Kevin Collins, Purchasing/Warehouse Supervisor  
Aaron Cook, Engineering Manager  
Noelle Denke, Public Affairs Specialist  
Steve Stone, Field Services Manager  
Lauren Eckert, Executive Assistant/Board Secretary

Also present were others, including, but not limited to: Steven Gortler

PLEDGE OF ALLEGIANCE

Vice President Baxter led the Pledge of Allegiance.

APPROVAL OF AGENDA

MOTION: Director McDougal moved to approve the agenda as presented; Director Endter seconded. Motion passed; VOTE:

AYES: Directors Baxter, Endter, McDougal, and Wolk

NOES: None

ABSTAIN: None

ABSENT: Director DeMeo

PUBLIC COMMENT

*Members of the public are invited to address the Board of Directors on any item that is within the subject matter jurisdiction of the legislative body. The Board President may limit comments to three (3) minutes.*

There were no public comments.

- A. APPOINTMENTS TO BOARD STANDING COMMITTEES
  - 1. Fiscal Policy & Insurance
  - 2. Personnel
  - 3. Engineering & Operations

The Board Standing Committee appointments remained unchanged as follows:

1. Fiscal Policy & Insurance: Directors Wolk and McDougal
2. Personnel: Directors DeMeo and McDougal
3. Engineering & Operations: Directors Baxter and Endter

- B. 2020 EMPLOYEE OF THE YEAR; RESOLUTION NO 5004
1. Chris Hamilton

The Board recognized and commended Chris Hamilton for being voted as Employee of the Year for 2020 by his peers.

MOTION: Director Wolk moved to approve Resolution No. 5004, recognizing and commending Chris Hamilton for being voted as Employee of the Year for 2020 by his peers; Director McDougal seconded. Motion carried; VOTE:

AYES: Directors Baxter, Endter, McDougal, and Wolk  
NOES: None  
ABSTAIN: None  
ABSENT: Director DeMeo

- C. YEARS OF SERVICE
1. Joye Johnson – 5 years

The Board recognized Joye Johnson for her five years of service to the District.

- II. **CONSENT CALENDAR**-----**(ITEM D)**  
*All items appearing on the Consent Calendar may be disposed of by a single motion. Items shall be removed from the Consent Calendar if any member of the Board of Directors or the public requests removal prior to a vote on a motion to approve the items. Such items shall be considered separately for action by the Board.*

- D. CONSIDER APPROVAL OF MINUTES
1. December 7, 2020 Combined November/December Regular Board Meeting

Recommendation: The Board approve the minutes of the aforementioned meeting of the Board of Directors of the Fallbrook Public Utility District.

MOTION: Director Endter moved to approve the Consent Calendar as presented; Director McDougal seconded. Motion carried; VOTE:

AYES: Directors Baxter, Endter, McDougal, and Wolk  
NOES: None

ABSTAIN: None  
ABSENT: Director DeMeo

**III. INFORMATION -----(ITEMS E–H)**

**E. DEBT REFUNDING RESULTS**

*Presented by: David Shank, Assistant General Manager/Chief Financial Officer*

Registered Municipal Advisor, Steven Gortler presented a slideshow outlining the debt refunding results, including savings to the District.

Director McDougal noted the District initially thought the savings would be \$1,000,000, and the actual savings were closer to \$1,500,000. AGM/CFO Shank reported the cost of issuance was less than what was initially estimated.

Director Wolk questioned the SRF loan interest figures shown in the presentation. Registered Municipal Advisor Gortler reported that originally there was \$24.6M in unpaid principal and \$4.86M in interest that would have been paid over the life of the bond. After refinancing, there was only \$19.8M principal on the new bond instead of \$24.6M and \$6.1M in interest instead of \$4.86M. Therefore, the District was paying back a lot more interest and less principal than it would have by not refunding the loan. The bonds were structured this way to attract interested investors.

General Manager Bebee acknowledged the effort by the FP&I Committee and Finance Department to put the District in a situation where the refunding was possible.

**F. MID-YEAR BUDGET UPDATE**

*Presented by: David Shank, Assistant General Manager/Chief Financial Officer*

Assistant General Manager/CFO Shank presented a slide show that provided an overview and update of the mid-year budget.

Director Endter asked if the government would reimburse the District for employees out on leave because of COVID. AGM/CFO Shank responded that the District was not reimbursed.

General Manager Bebee acknowledged the amount of work the FP&I Committee had done to make the budget extremely accurate.

G. FY20-21 CAPITAL PROJECTS UPDATE

Presented by: *Aaron Cook, Engineering Manager*

Engineering Manager Cook presented a slide show that provided a mid-year capital improvement project update.

Vice President Baxter asked if the backflow replacement priority was due to regulatory requirements. General Manager Bebee reported that there was a realization that there were backflow devices in need of immediate attention.

Vice President Baxter asked how close we would get to the year-end goal for meter replacement. Field Services Manager Stone thought there would be another 400-500 completed by the end of the fiscal year, but it would be hard to say definitively.

Director Wolk asked if the 4,000 linear feet of pipeline for the SMRCUP project was included in the pipeline replacement goal. Engineering Manager Cook responded that the portion for the SMRCUP project was replacing an old line that would need replacement. Engineering Manager Cook confirmed the 4,000 feet that was part of the SMRCUP project was included in the 6,600 feet goal.

Director McDougal asked if the construction of the new assisted living facility had an impact on the District's new pump station on Mission Road. Engineering Manager Cook responded that it was just a coincidence that the construction was happening at the same time, and there was no impact.

Vice President Baxter asked for a more detailed explanation of the recycled reuse pilot program. General Manager Bebee suggested a detailed presentation could be presented at the next Board meeting to give a clearer picture.

H. SMRCUP GAC TREATMENT UPDATE

Presented by: *Aaron Cook, Engineering Manager*

Engineering Manager Cook provided an update to the SMRCUP GAC Treatment Project.

Engineering Manager Cook announced they have already requested an amendment to the state revolving loan to cover these GAC costs. General Manager Bebee reported the official amendment and change order would come back to the Board for action in the future.

IV. ACTION / DISCUSSION CALENDAR ----- (ITEMS I-K)

I. CONSIDER ANNUAL REVIEW OF DIRECTORS' PER DIEM COMPENSATION

*Recommendation: Staff supports Board decision.*

General Manager Bebee announced Directors' per diem was reviewed annual, and there was an option to increase the compensation by five percent.

General Counsel de Sousa reported the action item at this meeting was to direct staff to set a Public Hearing at the next meeting for increasing Director per diem compensation.

MOTION: Director McDougal moved to begin the process of increasing Director per diem compensation by 5%, which will require a noticed Public Hearing in February; Director Endter seconded. Motion passed; VOTE:

AYES: Directors Baxter, Endter, McDougal, and Wolk  
NOES: None  
ABSTAIN: None  
ABSENT: Director DeMeo

J. CONSIDER UPDATES TO RECYCLED WATER PROVISIONS (ARTICLE 28) AND RECYCLED WATER USER AGREEMENT

*Recommendation: That the Board adopt Resolution No. 5005, amending Administrative Code Article 28 and adopt the proposed changes to the Recycled Water User Agreement*

General Manager Bebee stated the changes to the Recycled Water Provisions and Recycled Water User Agreement were largely administrative, ensuring consistency with today's regulations.

MOTION: Director Endter moved to adopt Resolution No. 5005, amending Administrative Code Article 28 and to adopt the proposed changes to the Recycled Water User Agreement; Director McDougal seconded. Motion passed; VOTE:

AYES: Directors Baxter, Endter, McDougal, and Wolk  
NOES: None  
ABSTAIN: None  
ABSENT: Director DeMeo

K. CONSIDER REQUEST TO PURCHASE PLANNED REPLACEMENT FLEET VEHICLES FOR FY 2021



*Recommendation: The Board approve a purchase of four vehicles from Courtesy Chevrolet in the total amount of \$112,860.13.*

General Manager Bebee stated there was an overall fleet and vehicle replacement program that included a methodology that addressed fleet vehicles, ensuring a cost effective approach. Three vehicles were now scheduled for replacement, and one additional vehicle was budgeted for a new position.

Vice President Baxter noted there was a savings of over \$87,000 from budget.

Director Wolk thought it was important to revise the criteria of how the District replaced vehicles, as the vehicles were relatively low mileage, which should be more of a criteria than age. Director Wolk noted regular maintenance, including oil changes should not be included in the maintenance cost.

MOTION: Director Endter moved to approve a purchase of four vehicles from Courtesy Chevrolet in the total amount of \$112,860.13; Director McDougal seconded. Motion passed; VOTE:

AYES: Directors Baxter, Endter, McDougal, and Wolk

NOES: None

ABSTAIN: None

ABSENT: Director DeMeo

#### IV. ORAL/WRITTEN REPORTS ----- (ITEMS 1-8)

##### 1. General Counsel

- General Counsel de Sousa noted SB 231, similar to SB 998, would potentially require the District to waive connection fees and not terminate water service for non-payment if there is a State or County declared emergency.

##### 2. SDCWA Representative Report

- General Manager Bebee noted there was a meeting Thursday to review the budget and the two-year budget going forward, and he will provide an update at the February Board meeting.

##### 3. General Manager

###### a. Engineering and Operations Report

- General Manager Bebee reported the written report was included in the agenda packet.
  - i. Director Wolk asked why there was a spike in unplanned disruptions in December. General Manager Bebee stated he will get back to Director Wolk on these events.

4. Assistant General Manager/Chief Financial Officer
  - a. Financial Summary Report
  - b. Treasurer's Report
  - c. Budget Status Report
  - d. Warrant List
    - AGM/CFO Shank provided an overview of the written reports included in the agenda packet.
5. Public Affairs Specialist
  - Public Affairs Specialist Denke announced the District had received a lot of positive feedback from the public, including positive comments about Christian Hernandez, Chris Hamilton, and Matt Lian. She also provided an update for the student calendar contest.
6. Notice of Approval of Per Diem for Meetings Attended
  - Notification of approval for Director's attendance to ACWA Leadership Listening Session, held virtually, on December 16, 2020.
    - i. Vice President Baxter provided notice to the Board that he approved President DeMeo's attendance to the ACWA Leadership Listening Session, held virtually, on December 16, 2020.
7. Director Comments/Reports on Meetings Attended
8. Miscellaneous

#### ADJOURN TO CLOSED SESSION

Vice President Baxter announced that members of the public were welcome to continue to stay on the teleconference line while the Board was in Closed Session, however they would only hear silence. Following Closed Session and prior to adjournment, an oral announcement of reportable action, should there be any, would be made to the public on the teleconference line.

The Board of Directors adjourned to Closed Session at 5:47 p.m. following an oral announcement by General Counsel de Sousa of Closed Session Items V.1 through V.3.

#### **VI. CLOSED SESSION ----- (ITEMS 1-3)**

1. CONFERENCE WITH LEGAL COUNSEL – ANTICIPATED LITIGATION SIGNIFICANT EXPOSURE TO LITIGATION PURSUANT TO GOVERNMENT CODE SECTION 54956.9 (d)(2)  
  
*One (1) Potential Case*
2. CONFERENCE WITH LEGAL COUNSEL – EXISTING LITIGATION PURSUANT TO GOVERNMENT CODE SECTION 54956.9 (d)(1):

*Name of Case: Todd Lange v. Fallbrook Public Utility District, San Diego Co. Sup. Ct. (North County) Case No 37-2020-00046705-CU-PT-NC*

3. CONFERENCE WITH LEGAL COUNSEL – EXISTING LITIGATION PURSUANT TO GOVERNMENT CODE SECTION 54956.9 (d)(1):

*Name of Case: Bonnie Kessner and Andrea McCartney-Page, et al. vs. City of Santa Clara et al., Santa Clara Co. Sup. Ct. Case Number 20CV364054*

RECONVENE TO OPEN SESSION

The Board returned from Closed Session and reconvened to Open Session at 6:14 p.m.

REPORT FROM CLOSED SESSION (*As necessary*)

There was no reportable action taken in Closed Session.

**VII. ADJOURNMENT OF MEETING**

There being no further business to discuss, the January Regular Meeting of the Fallbrook Public Utility District was adjourned at 6:14 p.m.

\_\_\_\_\_  
President, Board of Directors

ATTEST:

\_\_\_\_\_  
Secretary, Board of Directors

**M E M O**

**TO:** Board of Directors  
**FROM:** Larry Ragsdale, Safety and Risk Officer  
**DATE:** February 22, 2021  
**SUBJ:** Claim For Inundation Of Water Onto Real Property

---

Purpose

To present claims filed for property damage.

Summary

January 16, 2021 Claimants allege the main line break caused damage to private property and landscaping.

Budgetary Impact

Impact analysis cost cannot be determined until JPIA rules on its disposition. Other factors that affect the budgetary impact vary from the claims process, cost, and litigation. Due to these factors, the impact cannot be established at this time.

Recommended Action

The aggregate cost of the claims related to the incident will exceed the District retrospective allocation point of \$25,000. Staff recommends rejection of this claim, and any and all claims resulting from this incident, and to forward all claims for this incident to ACWA/JPIA for resolution.

# Claim Form

(A claim shall be presented by the claimant or by a person acting on his behalf.)

## NAME OF DISTRICT:

1

Claimant name, address (mailing address if different), phone number, social security number, e-mail address, and date of birth.

Effective January 1, 2010, the Medicare Secondary Payer Act (Federal Law) requires the District/Agency to report all claims involving payments for bodily injury and/or medical treatments to Medicare. As such, if you are seeking medical damages we MUST have both your Social Security Number and your date of birth.

Name: THOMAS E. ROSSI

Phone Number: [REDACTED]

Address:

Social Security No.:

FALLBROOK, CA 92028

Date of Birth:

E- [REDACTED]

2

List name, address, and phone number of any witnesses.

Name: DAVE DEVEDORE

Address: [REDACTED]

Phone Number: [REDACTED]

3

List the date, time, place, and other circumstances of the occurrence or transaction, which gave rise to the claim asserted.

Date: 1.16.21 Time: EARLY MORN. Place: [REDACTED]

Tell What Happened (give complete information): ALSO SEE ATTACHED EMAIL PRINTOUT

FPUD WATER MAIN LINE RUPTURED IN THE EARLY MORNING HOURS OF 1.16.21. WATER GUSHED OUT OF RUPTURED LINE AND FLOODED 1507 KNOWLAK LANE PROPERTY. EXTENT OF DAMAGE TO HOUSE AND PROPERTY T.B.D.

NOTE: Attach any photographs you may have regarding this claim.

4

Give a general description of the indebtedness, obligation, injury, damage, or loss incurred so far as it may be known at the time of presentation of the claim.

YOUR FOREMAN AUSTIN WENDT: 1.760.497.5774 TOOK MANY DETAILED PHOTOS OF ALL THE VISIBLE DAMAGE. I ALSO HAVE PICTURES IF NEEDED

5

Give the name or names of the public employee or employees causing the injury, damage, or loss, if known.

6

The amount claimed if it totals less than ten thousand dollars (\$10,000) as of the date of presentation of the claim, including the estimated amount of any prospective injury, damage or loss, insofar as it may be known at the time of the presentation of the claim, together with the basis of computation of the amount claimed. If the amount claimed exceeds ten thousand dollars (\$10,000), no dollar amount shall be included in the claim. However, it shall indicate whether the claim would be a limited civil case.

Date: 1.16.21 Time: 5:30 PM Signature: [Signature]

THOMAS ROSSI

ANSWER ALL QUESTIONS. OMITTING INFORMATION COULD MAKE YOUR CLAIM LEGALLY INSUFFICIENT!



20210116\_063059



20210116\_063110

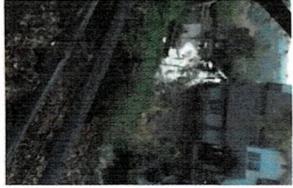

20210116\_063613



20210116\_063810



20210116\_063822



20210116\_063838



20210116\_063842



20210116\_064033



20210116\_071124



20210116\_071534



20210116\_071547



20210116\_071552



20210116\_071554



20210116\_071939



20210116\_090554



20210116\_090604



20210116\_090610



20210116\_090621



20210116\_090627



20210116\_090630



20210116\_143702



20210116\_152621



20210116\_152629



20210116\_152632



20210116\_152646



20210116\_152658



20210116\_152704



20210116\_152728



20210116\_152805



20210116\_152814



20210116\_152820



20210116\_152844



20210116\_152846



20210116\_152850



20210116\_152859



20210116\_152938



20210116\_154506



20210116\_154509



20210116\_154537



20210116\_154551



20210116\_154624

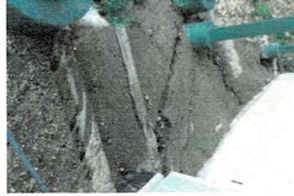

20210116\_154630



20210116\_154638



20210116\_154642



20210116\_154650



20210116\_154711



20210116\_154714

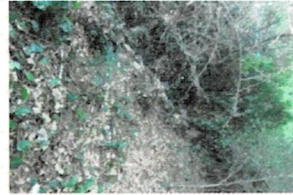

20210116\_154751



20210116\_154754



20210116\_154815

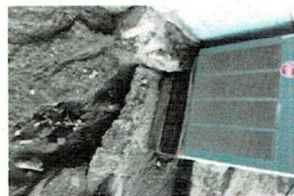

20210116\_154833



20210116\_154843



20210116\_154849

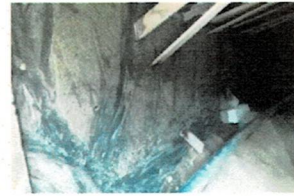

20210116\_154921



20210116\_154953



20210116\_155142



20210116\_160541



20210116\_160549



c7d4e52d35247d28411de964



20210116\_063054

Agent Description

Stamp: 1/16/2021 7:32:33 AM - RMH  
Ask Caller: Water Emergency  
Water Spill?: Yes  
Water Spill Type: Recycled Water Spill  
Caller: UNDERWOOD ,. ROBERT  
Account Number: N/A  
Ph: [REDACTED]

Address: [REDACTED]

City: FALLBROOK

Zip Code: 92028

Re: I HAVE NO WATER PRESSURE AND WATER IS RUNNING DOWN MY STREET

Successful Dispatch: Yes

Dispatch Type: Relay

	HistoryStamp	DispositionType	Disposition	Agent	Description
History	1/16/2021 7:36:26AM	Generic	Dial 760-497-3985	RMH	
History	1/16/2021 7:36:26AM	Generic	Dialed - Water Standby Phone	RMH	Water Standby Phone
History	1/16/2021 7:37:18AM	DispatchAdded	Dispatch added	RMH	
History	1/16/2021 7:37:18AM	Taken	Taken	RMH	Water Standby Phone
History	1/16/2021 7:38:56AM	Edited	Edited	CGC	Water Standby Phone
History	1/16/2021 7:38:56AM	DispatchDeleted	Dispatch deleted(MessageSaved)	CGC	Water Standby Phone
History	1/16/2021 7:38:56AM	Delivered	Delivered	CGC	

2783262

Discarded: N Exported: N Urgent: N Taken: 1/16/2021 7:38:19AM Op: CGC Delivered: 1/16/2021 7:38:19AM

Stamp: 1/16/2021 7:37:31 AM - CGC

Check In Description: Office Calling with Account Update

Check-In/OnCall Notes: THERE IS A WATER MAIN BREAK ON KNOLL PARK AND LANE NO ETA.

CallerID: [REDACTED]

	HistoryStamp	DispositionType	Disposition	Agent
History	1/16/2021 7:38:19AM	Unknown	email initiated to changes@southwestansweringservice.com	CGC
History	1/16/2021 7:38:19AM	Taken	Taken	CGC
History	1/16/2021 7:38:19AM	Delivered	Delivered	CGC
History	1/16/2021 7:38:19AM	Delivered	Delivered	CGC
History	1/16/2021 7:38:21AM	Unknown	email completed to changes@southwestansweringservice.com	CGC

2783272

Discarded: N Exported: N Urgent: N Taken: 1/16/2021 7:45:47AM Op: CMR Delivered: 1/16/2021 7:45:47AM



**GENERAL INCIDENT INFORMATION**  
**Form "A" Property Liability - Accept/Reject endorsements**

Event ID: 21-302  
 DOI: 1/16/2021  
 Type Claim: Real property  
 Parties address: ██████████ Fallbrook, CA 92028  
**Timeliness of Claim: 0 Year(s) 0 Month(s) 0 Days**

Name of Party: Tom Rossi  
 Contact # ██████████  
 Email: ██████████  
 Company: Property owner

Type of Incident: <b>Water Damage</b>		Nature of Incident: <b>Main line break</b>	
Incident Description: Claimant alleges the inundation of water to his house foundation caused structural and property damage.			
Location of Incident: <b>Knoll Park Lane</b>			
Date Claim Received:	1/16/2021	Date Closed:	
Settlement:			
Release Signed:		Incident Reported to JPIA:	
REMARKS:	<i>Claim has been determined to exceed our RAP of \$25,000. Current estimate is \$50,000.</i> <i>JPIA has assigned Claim# 21-0473 to this main line break incident which is to be applied to any and all additional claims related to this main line incident.</i>		

**ACCEPT/DENY**

Date: 2/11/21      *[Signature]*      Safety & Risk Officer      Claim Request:  Accept  Deny

Remarks:

Date: 02/11/2021      *[Signature]*      Assistant General Manager / CFO      Claim Request:  Accept  Deny

Remarks:

Date: 02/11/2021      *[Signature]*      General Manager      Claim Request:  Accept  Deny

Remarks:

**BOARD ACTION** If applicable

Accept     Deny

**M E M O**

**TO:** Board of Directors  
**FROM:** Engineering & Operations Committee  
**DATE:** February 22, 2021  
**SUBJECT:** Easement Quitclaim for 420 West Dougherty Street

---

Description

Quitclaim an existing utility easement at 420 West Dougherty Street that is part of an abandoned subdivision plan.

Purpose

An easement was granted to the District on June 6, 2008 as part of Tentative Map 5339-1, which planned to subdivide the property at 420 West Dougherty Street into 28 residential lots. The development plans have been abandoned per Tentative Map 5642-2020. The property owner, Dougherty Citrus, Inc., is requesting that the District quitclaim the easement since it is no longer necessary.

Budgetary Impact

No budgetary impact.

Recommended Action

The Board approve authorization to quitclaim the easement recorded as Document No. 2008-0306324.

January 26, 2021  
W.O. 673-0903-400

Soleil Develle  
Engineering Technician  
Fallbrook Public Utility District  
990 East Mission Road  
Fallbrook, CA 92028

RECEIVED  
FEB 13 2021  
BY: \_\_\_\_\_

**RE: QUITCLAIM REQUEST FOR 420 WEST DOUGHERTY STREET, FALLBROOK, CA**

Dear Mr. Develle:

The owners of the Dougherty Citrus project located at 420 West Dougherty Street have decided not to go forward with the development of their subdivision-County of San Diego TM 5339-1. The final map for this project was recorded on January 19, 2016 as Map No. 16088. They have filed a tentative map with the County to revert the subdivision back to acreage(County PDS2020-TM-5642).

As part of this process, BHA, on behalf of Dougherty Citrus Inc. hereby requests that the Fallbrook Public Utility District quitclaim an easement granted to the District as Document No. 2008-0306324, recorded on June 6, 2008. We have attached a copy of the document with this letter.

The property owner is Dougherty Citrus, Inc. The President of the Corporation is Richard Cicoletti. Their mailing address is 2784 James Drive, Carlsbad, CA 92008.

We have enclosed a check in the amount of \$50.00 for the processing fee along with an exhibit of the easement to be quitclaimed, and a WORD document with the legal description of the easement.

Sincerely,

**bHA, Inc.**

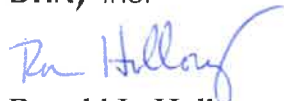

Ronald L. Holloway  
Senior Vice President

RLH:

cc: Richard Cicoletti

RECORDING REQUESTED BY  
AND WHEN RECORDED MAIL THIS DEED  
AND, UNLESS OTHERWISE SHOWN  
BELOW, MAIL TAX STATEMENTS TO:

Fallbrook Public Utility District  
990 E. Mission Rd.  
Fallbrook, CA 92028

SPACE ABOVE THIS LINE FOR RECORDER'S USE

## Quitclaim Deed

*This is NOT a transfer of property; it is only a relinquishment of rights to an easement, therefore, a Preliminary Change of Ownership form is not necessary in this case.*

The undersigned declares that the documentary transfer fee is \$ \_\_\_\_\_ -0- \_\_\_\_\_ and is  
 computed on the full value of the interest or property conveyed, or is  
\_\_\_\_\_ computed on the full value less the value of liens or encumbrances remaining thereon at the time of sale.

The land, tenements or realty is located in

unincorporated area \_\_\_\_\_ city of \_\_\_\_\_ and

FOR A VALUABLE CONSIDERATION, receipt of which is hereby acknowledged,

### FALLBROOK PUBLIC UTILITY DISTRICT

A corporation organized under the laws of the state of California, does hereby remise, release and forever quitclaim to

### Dougherty Citrus, Inc

The following described real property in the County of San Diego, State of California:

### SEE ATTACHED EXHIBIT 'A' AND 'B'

(Also Known as Easement Document 2008-0306324)

\_\_\_\_\_  
Date: \_\_\_\_\_  
President, FPUD Board of Directors  
Name:

\_\_\_\_\_  
Date: \_\_\_\_\_  
Secretary, FPUD Board of Directors  
Name: Lauren Echert

## EXHIBIT "A"

### LEGAL DESCRIPTION

#### EASEMENT FOR PUBLIC UTILITIES, INGRESS AND EGRESS

A PORTION OF RANCHO SANTA MARGARITA Y LAS FLORES AS DELINEATED UPON A MAP RECORDED IN BOOK 7, PAGE 39 OF PATENTS AND AS SHOWN BY RECORD OF SURVEY MAPS 794 AND 831 FILED IN THE RECORDER'S OFFICE, AND A PORTION OF LOT 1 IN FRACTIONAL SECTION 24, TOWNSHIP 9 SOUTH, RANGE 4 WEST, SAN BERNARDINO MERIDIAN, ACCORDING TO THE OFFICIAL PLAT OF SAID LAND FILED IN THE DISTRICT LAND OFFICE JULY 31, 1880, ALL BEING IN THE COUNTY OF SAN DIEGO COUNTY, STATE OF CALIFORNIA, MORE PARTICULARLY DESCRIBED AS FOLLOWS:

#### PARCEL A

COMMENCING AT THE NORTHWEST CORNER OF THE LAND DESCRIBED IN THE DEED TO NICHOLAS J. MARIANI, ET UX, RECORDED MARCH 15, 1967 AS FILE NO. 34943 OF OFFICIAL RECORDS; THENCE ALONG THE NORTHERLY LINE OF SAID LAND AND A PORTION OF THE NORTHERLY LINE OF SAID LOT 1, SOUTH 88°38'17" EAST 589.05 FEET TO **TRUE POINT OF BEGINNING**; THENCE CONTINUING ALONG SAID NORTHERLY LINE, SOUTH 88°38'17" EAST, 207.36 FEET TO THE MOST NORTHWESTERLY CORNER OF PARCEL 1 OF PARCEL MAP NO. 4426 FILED IN THE OFFICE OF THE COUNTY RECORDER OF SAID SAN DIEGO COUNTY, JANUARY 30, 1976; THENCE ALONG THE BOUNDARY LINES OF SAID PARCEL 1, SOUTH 01°03'13" WEST, 20.00 FEET; THENCE NORTH 88°38'17" WEST, 135.53 FEET; THENCE SOUTH 12°46'04" EAST, 2.09 FEET TO THE BEGINNING OF A NON TANGENT CURVE CONCAVE TO THE SOUTHEAST HAVING A RADIUS OF 25.00 FEET, A RADIAL LINE FROM SAID POINT BEARS SOUTH 11°31'15" EAST; THENCE LEAVING THE EASTERLY LINE OF SAID PARCEL 1, SOUTHWESTERLY ALONG SAID CURVE, THROUGH A CENTRAL ANGLE OF 69°22'56", AN ARC DISTANCE OF 30.27 FEET TO THE BEGINNING OF A REVERSE CURVE CONCAVE TO THE NORTH HAVING A RADIUS OF 40.00 FEET; THENCE SOUTHWESTERLY AND WESTERLY ALONG SAID CURVE, THROUGH A CENTRAL ANGLE OF 119°20'06", AN ARC DISTANCE OF 83.31 FEET TO THE BEGINNING OF A REVERSE CURVE CONCAVE TO THE SOUTHEAST HAVING A RADIUS OF 25.00 FEET; THENCE NORTHWESTERLY AND SOUTHERLY ALONG SAID CURVE, THROUGH A CENTRAL ANGLE OF 165°28'35", AN ARC DISTANCE OF 72.20 FEET TO A POINT HEREINAFTER REFERED TO AS **POINT "A"**; THENCE SOUTH 54°57'35" WEST, 40.02 FEET TO THE BEGINNING OF A NON TANGENT CURVE CONCAVE TO THE SOUTH HAVING A RADIUS OF 25.00 FEET, A RADIAL LINE FROM SAID POINT BEARS SOUTH 52°57'21" WEST; THENCE WESTERLY ALONG SAID CURVE, THROUGH A CENTRAL ANGLE OF 81°13'32", AN ARC DISTANCE OF 35.44 FEET TO THE BEGINNING OF A REVERSE CURVE CONCAVE TO THE NORTH HAVING A RADIUS OF 270.00 FEET; THENCE SOUTHWESTERLY ALONG SAID CURVE, THROUGH A CENTRAL ANGLE OF 17°54'36", AN ARC DISTANCE OF 84.40 FEET; THENCE SOUTH 79°38'25" WEST, 252.76 FEET TO THE BEGINNING OF A CURVE CONCAVE TO THE SOUTHEAST HAVING A RADIUS OF 180.00 FEET; THENCE SOUTHWESTERLY ALONG SAID CURVE, THROUGH A CENTRAL ANGLE OF 72°52'52", AN ARC DISTANCE OF 228.96 FEET; THENCE SOUTH 06°45'33" WEST, 38.62 FEET TO A POINT HEREINAFTER REFERED TO AS **POINT "B"**; THENCE CONTINUING SOUTH 06°45'33" WEST, 90.00 FEET; THENCE CONTINUING SOUTH 06°45'33" WEST, 425.67 FEET TO THE BEGINNING OF A CURVE CONCAVE TO THE EAST HAVING A RADIUS OF 180.00 FEET; THENCE SOUTHERLY ALONG SAID CURVE, THROUGH A CENTRAL ANGLE OF 15°25'06", AN ARC

DISTANCE OF 48.44 FEET TO THE BEGINNING OF A COMPOUND CURVE CONCAVE TO THE NORTHEAST HAVING A RADIUS OF 25.00 FEET; THENCE SOUTHEASTERLY ALONG SAID CURVE, THROUGH A CENTRAL ANGLE OF 108°21'10", AN ARC DISTANCE OF 47.28 FEET; THENCE SOUTH 03°20'09" EAST, 43.68 FEET TO THE BEGINNING OF A NON TANGENT CURVE CONCAVE TO THE SOUTHEAST HAVING A RADIUS OF 25.00 FEET, A RADIAL LINE FROM SAID POINT BEARS SOUTH 27°00'43" EAST; THENCE SOUTHWESTERLY ALONG SAID CURVE, THROUGH A CENTRAL ANGLE OF 80°00'00", AN ARC DISTANCE OF 34.91 FEET; THENCE SOUTH 17°00'43" EAST, 19.43 FEET; THENCE SOUTH 46°32'03" WEST, 118.39 FEET; THENCE SOUTH 06°43'19" WEST, 165.59 FEET TO A POINT ON THE WESTERLY PROLONGATION OF THE SOUTHERLY LINE OF SAID LOT 1, SECTION 24; THENCE ALONG SAID LINE, NORTH 88°39'24" WEST, 20.09 FEET TO THE EASTERLY BOUNDARY OF FALLBROOK NAVAL WEAPONS STATION AS SHOWN ON RECORD OF SURVEY MAP NO. 9426, FILED IN THE OFFICE OF THE COUNTY RECORDER OF SAID SAN DIEGO COUNTY, AUGUST 11, 1983, THENCE ALONG SAID LINE, NORTH 06°43'19" EAST (NORTH 06°43'38" EAST PER ROS 9426), 174.71 FEET; THENCE LEAVING SAID LINE, NORTH 46°32'03" EAST, 96.60 FEET; THENCE SOUTH 72°59'17" WEST, 5.10 FEET; THENCE NORTH 17°00'43" WEST, 83.62 FEET TO THE BEGINNING OF A CURVE CONCAVE TO THE EAST HAVING A RADIUS OF 220.00 FEET; THENCE NORTHERLY ALONG SAID CURVE, THROUGH A CENTRAL ANGLE OF 23°46'16", AN ARC DISTANCE OF 91.27 FEET; THENCE NORTH 83°16'41" WEST, 4.92 FEET TO SAID LINE PER RECORD OF SURVEY 9426; THENCE ALONG SAID LINE NORTH 06°43'19" EAST, 193.16 FEET TO AN ANGLE POINT IN SAID LINE; THENCE CONTINUING ALONG SAID LINE, NORTH 06°45'33" EAST (NORTH 06°45'25" EAST PER ROS 9426), 361.13 FEET; THENCE LEAVING SAID LINE, SOUTH 83°14'27" EAST, 5.05 FEET TO THE BEGINNING OF A NON TANGENT CURVE CONCAVE TO THE SOUTHEAST HAVING A RADIUS OF 220.00 FEET, A RADIAL LINE FROM SAID POINT BEARS SOUTH 83°14'27" EAST; THENCE NORTHEASTERLY ALONG SAID CURVE, THROUGH A CENTRAL ANGLE OF 72°52'52", AN ARC DISTANCE OF 279.84 FEET; THENCE NORTH 79°38'25" EAST, 252.76 FEET TO THE BEGINNING OF A CURVE CONCAVE TO THE NORTHWEST HAVING A RADIUS OF 230.00 FEET; THENCE NORTHEASTERLY ALONG SAID CURVE, THROUGH A CENTRAL ANGLE OF 31°52'36", AN ARC DISTANCE OF 127.96 FEET TO THE BEGINNING OF A REVERSE CURVE CONCAVE TO THE SOUTHEAST HAVING A RADIUS OF 270.00 FEET; THENCE NORTHEASTERLY ALONG SAID CURVE, THROUGH A CENTRAL ANGLE OF 21°24'25", AN ARC DISTANCE OF 100.88 FEET TO THE POINT OF BEGINNING.

CONTAINING 1.757 ACRES, MORE OR LESS.

#### **PARCEL B**

BEGINNING AT THE AFORMENTIONED POINT "A"; THENCE SOUTH 37°02'39" EAST, 31.64 FEET TO THE BEGINNING OF A CURVE CONCAVE TO THE WEST HAVING A RADIUS OF 270.00 FEET; THENCE SOUTHERLY ALONG SAID CURVE, THROUGH A CENTRAL ANGLE OF 41°13'17", AN ARC DISTANCE OF 194.25 FEET; THENCE SOUTH 04°10'38" WEST, 65.83 FEET TO THE BEGINNING OF A CURVE CONCAVE TO THE WEST HAVING A RADIUS OF 270.00 FEET; THENCE SOUTHERLY ALONG SAID CURVE, THROUGH A CENTRAL ANGLE OF 18°44'23", AN ARC DISTANCE OF 88.31 FEET; THENCE SOUTH 22°55'01" WEST, 244.74 FEET TO THE BEGINNING OF A CURVE CONCAVE TO THE NORTHWEST HAVING A RADIUS OF 270.00 FEET; THENCE SOUTHWESTERLY ALONG SAID CURVE, THROUGH A CENTRAL ANGLE OF 52°19'17", AN ARC DISTANCE OF 246.56 FEET TO THE BEGINNING OF A REVERSE CURVE CONCAVE TO THE SOUTHEASTERLY HAVING A RADIUS OF 230.00 FEET; THENCE SOUTHWESTERLY ALONG SAID CURVE, THROUGH A CENTRAL ANGLE OF 12°15'01", AN ARC DISTANCE OF 49.18 FEET; THENCE SOUTH 62°59'17" WEST, 326.79 FEET; THENCE NORTH 03°20'09" WEST, 43.68 FEET; THENCE NORTH 62°59'17" EAST, 309.25 FEET TO THE BEGINNING OF A CURVE CONCAVE TO THE SOUTHEAST HAVING A RADIUS OF 270.00 FEET; THENCE

NORTHEASTERLY ALONG SAID CURVE, THROUGH A CENTRAL ANGLE OF 12°15'01", AN ARC DISTANCE OF 57.73 FEET TO THE BEGINNING OF A REVERSE CURVE CONCAVE TO THE NORTHWEST HAVING A RADIUS OF 230.00 FEET; THENCE NORTHEASTERLY ALONG SAID CURVE, THROUGH A CENTRAL ANGLE OF 52°19'17", AN ARC DISTANCE OF 210.03 FEET; THENCE NORTH 22°55'01" EAST, 34.58 FEET; THENCE CONTINUING NORTH 22°55'01" EAST, 90.00 FEET; THENCE CONTINUING NORTH 22°55'01" EAST, 120.15 FEET TO THE BEGINNING OF A CURVE CONCAVE TO THE WEST HAVING A RADIUS OF 230.00 FEET; THENCE NORTHERLY ALONG SAID CURVE, THROUGH A CENTRAL ANGLE OF 18°44'23", AN ARC DISTANCE OF 75.23 FEET; THENCE NORTH 04°10'38" EAST, 65.83 FEET TO THE BEGINNING OF A CURVE CONCAVE TO THE WEST HAVING A RADIUS OF 230.00 FEET; THENCE NORTHERLY ALONG SAID CURVE, THROUGH A CENTRAL ANGLE OF 41°13'17", AN ARC DISTANCE OF 165.47 FEET; THENCE NORTH 37°02'39" WEST, 33.04 FEET; THENCE NORTH 54°57'35" EAST, 40.02 FEET TO SAID POINT "A".

CONTAINING 1.105 ACRES, MORE OR LESS.

### PARCEL C

BEGINNING AT THE AFORMENTIONED POINT "B" SAID POINT BEING THE BEGINNING OF A CURVE CONCAVE TO THE NORTHEAST, HAVING A RADIUS OF 25.00 FEET, A RADIAL LINE FROM SAID POINT BEARS NORTH 83°14'27" WEST; THENCE SOUTHEASTERLY ALONG SAID CURVE, THROUGH A CENTRAL ANGLE OF 89°59'34" AN ARC DISTANCE OF 39.27 FEET; THENCE SOUTH 83°14'01" EAST, 79.40 FEET TO THE BEGINNING OF A CURVE CONCAVE TO THE SOUTH HAVING A RADIUS OF 270.00 FEET; THENCE EASTERLY ALONG SAID CURVE, THROUGH A CENTRAL ANGLE OF 16°09'02", AN ARC DISTANCE OF 76.11 FEET; THENCE SOUTH 67°04'59" EAST, 326.21 FEET TO THE BEGINNING OF A CURVE CONCAVE TO THE NORTH HAVING A RADIUS OF 25.00 FEET; THENCE EASTERLY ALONG SAID CURVE, THROUGH A CENTRAL ANGLE OF 90°00'00", AN ARC DISTANCE OF 39.27 FEET; THENCE SOUTH 22°55'01" WEST, 90.00 FEET TO THE BEGINNING OF A NON TANGENT CURVE CONCAVE TO THE WEST HAVING A RADIUS OF 25.00 FEET, A RADIAL LINE FROM SAID POINT BEARS NORTH 67°04'59" WEST; THENCE NORTHERLY ALONG SAID CURVE, THROUGH A CENTRAL ANGLE OF 90°00'00", AN ARC DISTANCE OF 39.27 FEET; THENCE NORTH 67°04'59" WEST, 326.21 FEET TO THE BEGINNING OF A CURVE CONCAVE TO THE SOUTH HAVING A RADIUS OF 230.00 FEET; THENCE WESTERLY ALONG SAID CURVE, THROUGH A CENTRAL ANGLE OF 16°09'02", AN ARC DISTANCE OF 64.83 FEET; THENCE NORTH 83°14'01" WEST, 79.39 FEET TO THE BEGINNING OF A CURVE CONCAVE TO THE SOUTHEAST HAVING A RADIUS OF 25.00 FEET; THENCE SOUTHWESTERLY ALONG SAID CURVE, THROUGH A CENTRAL ANGLE OF 90°00'26", AN ARC DISTANCE OF 39.27 FEET; THENCE NORTH 06°45'33" EAST, 90.00 FEET TO SAID POINT "B".

CONTAINING 0.495 ACRES, MORE OR LESS.

THIS LEGAL DESCRIPTION WAS PREPARED  
BY ME OR UNDER MY DIRECTION

---

ARMAND A. MAROIS  
PLS 5941

DATE

# EXHIBIT B

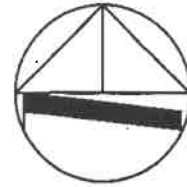

SCALE 1"=300'

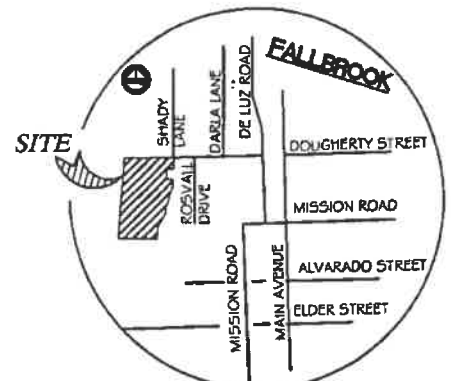
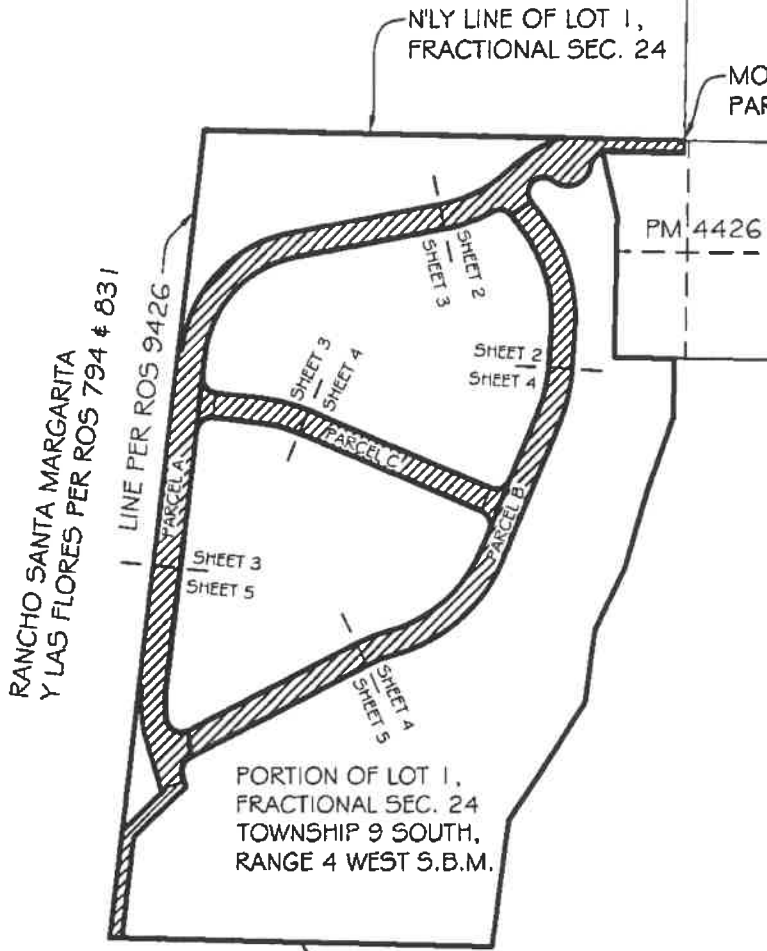

VICINITY MAP

NTS

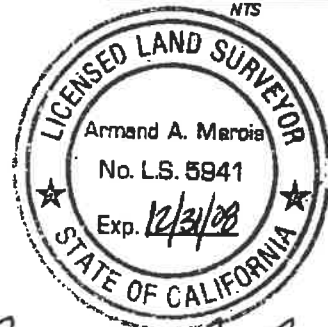

*Armand A. Marois*  
 ARMAND A. MAROIS  
 P.L.S. 5941

DATED: 3/18/08

## LEGEND

- INDICATES EASEMENT FOR PUBLIC UTILITIES, AND INGRESS AND EGRESS (WIDTH VARIES) TO FALLBROOK PUBLIC UTILITY DISTRICT  
 TOTAL AREA = 3.357 ACRES
- INDICATES SHEET MATCHLINE
- P.O.C. INDICATES POINT OF COMMENCMENT
- T.P.O.B. INDICATES TRUE POINT OF BEGINNING
- (R) INDICATES RADIAL BEARING

PUBLIC UTILITIES AND INGRESS AND EGRESS EASEMENT

DOUGHERTY CITRUS, INC.  
 TO  
 FALLBROOK PUBLIC UTILITY DISTRICT

**bha, Inc.**  
 5115 AVENIDA ENCINAS SUITE L  
 CARLSBAD, CA. 92008 (760) 931-8700  
 W.O. 673-0903-400



# EXHIBIT B

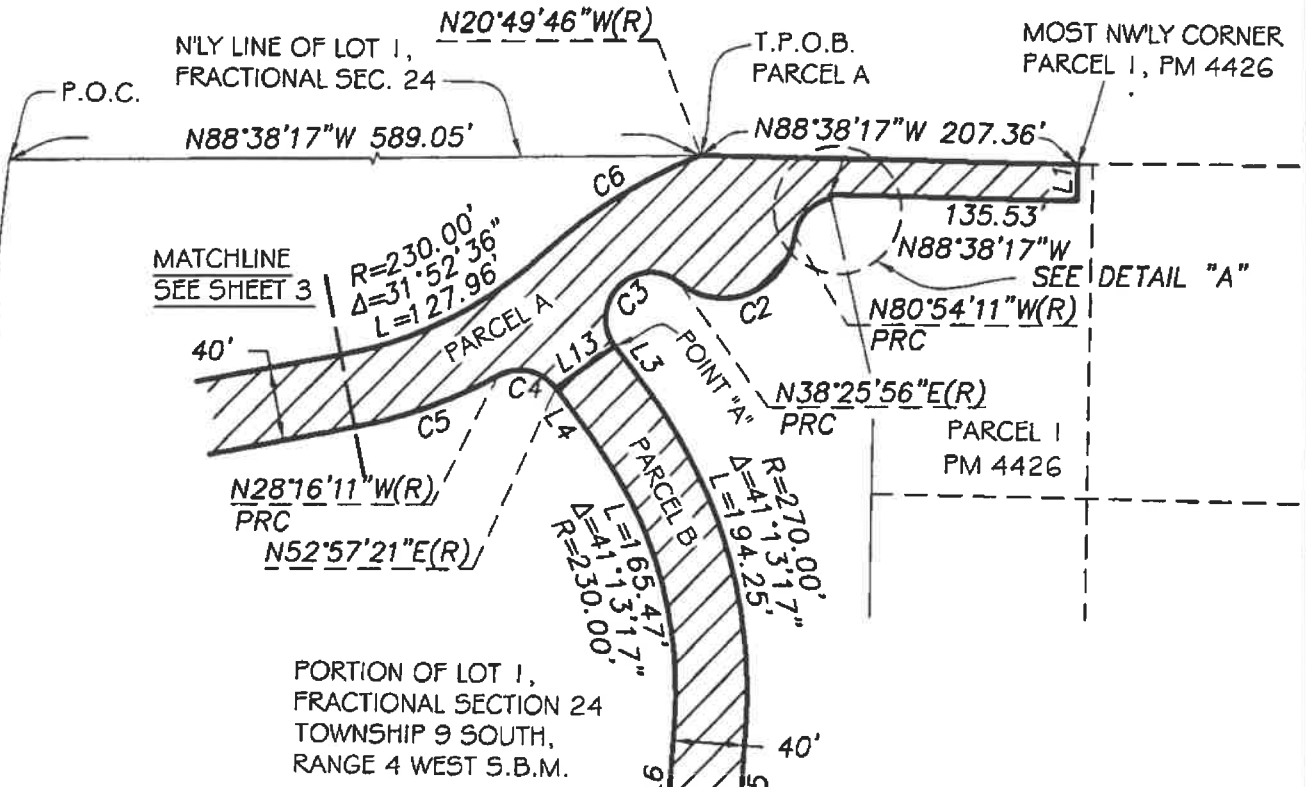

**LEGEND** INDICATES PUBLIC UTILITIES AND INGRESS AND EGRESS EASEMENT (WIDTH VARIES) TO FALLBROOK PUBLIC UTILITY DISTRICT  
 TOTAL AREA = 3.357 ACRES

P.O.C. INDICATES POINT OF COMMENCEMENT  
 T.P.O.B. INDICATES TRUE POINT OF BEGINNING

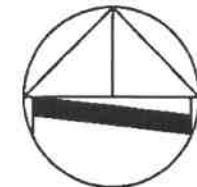

SCALE 1"=100'

LINE TABLE		
LINE	BEARING	DISTANCE
L1	N01°03'13"E	20.00'
L2	N12°46'04"W	2.09'
L3	N37°02'39"W	31.64'
L4	N37°02'39"W	33.04'
L5	N04°10'38"E	65.83'
L6	N04°10'38"E	65.83'
L13	N54°57'35"E	40.02'

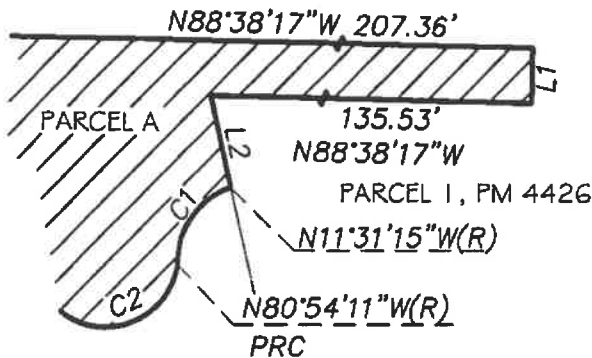

**DETAIL "A"**  
 NTS  
 EXAGGERATED FOR CLARITY

CURVE TABLE			
CURVE	LENGTH	RADIUS	DELTA
C1	30.27'	25.00'	69°22'56"
C2	83.31'	40.00'	119°20'07"
C3	72.20'	25.00'	165°28'35"
C4	35.44'	25.00'	81°13'32"
C5	84.40'	270.00'	17°54'36"
C6	100.88'	270.00'	21°24'25"

**bHA, Inc.**  
 5115 AVENIDA ENCINAS SUITE L  
 CARLSBAD, CA. 92008 (760) 931-8700  
 W.O. 673-0903-400

# EXHIBIT B



SCALE 1"=100'

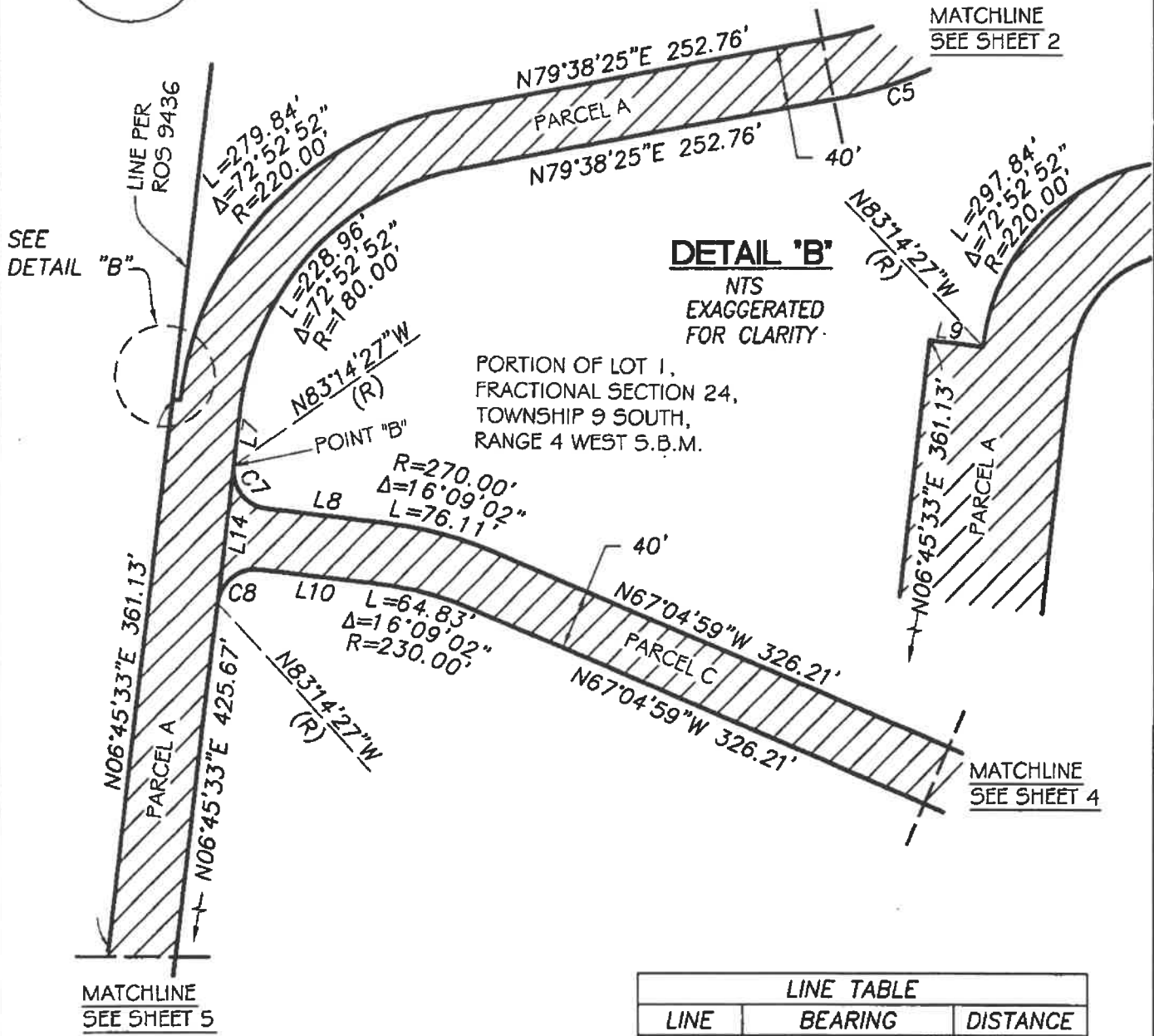

## LEGEND

INDICATES PUBLIC UTILITIES AND INGRESS AND EGRESS EASEMENT (WIDTH VARIES) TO FALLBROOK PUBLIC UTILITY DISTRICT  
TOTAL AREA = 3.357 ACRES

LINE TABLE		
LINE	BEARING	DISTANCE
L7	N06°45'33"E	38.62'
L8	N83°14'01"W	79.40'
L9	N83°14'27"W	5.05'
L10	N83°14'01"W	79.39'
L14	N06°45'33"W	90.00'

CURVE TABLE			
CURVE	LENGTH	RADIUS	DELTA
C7	39.27'	25.00'	89°59'34"
C8	39.27'	25.00'	90°00'26"

**bHA, Inc.**  
5115 AVENIDA ENCINAS SUITE L  
CARLSBAD, CA. 92008 (760) 931-8700  
W.O.673-0903-400

# EXHIBIT B

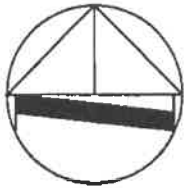

SCALE 1"=100'

MATCHLINE  
SEE SHEET 2

MATCHLINE  
SEE SHEET 3

PORTION OF LOT 1,  
FRACTIONAL SECTION 24,  
TOWNSHIP 9 SOUTH,  
RANGE 4 WEST S.B.M.

MATCHLINE  
SEE SHEET 5

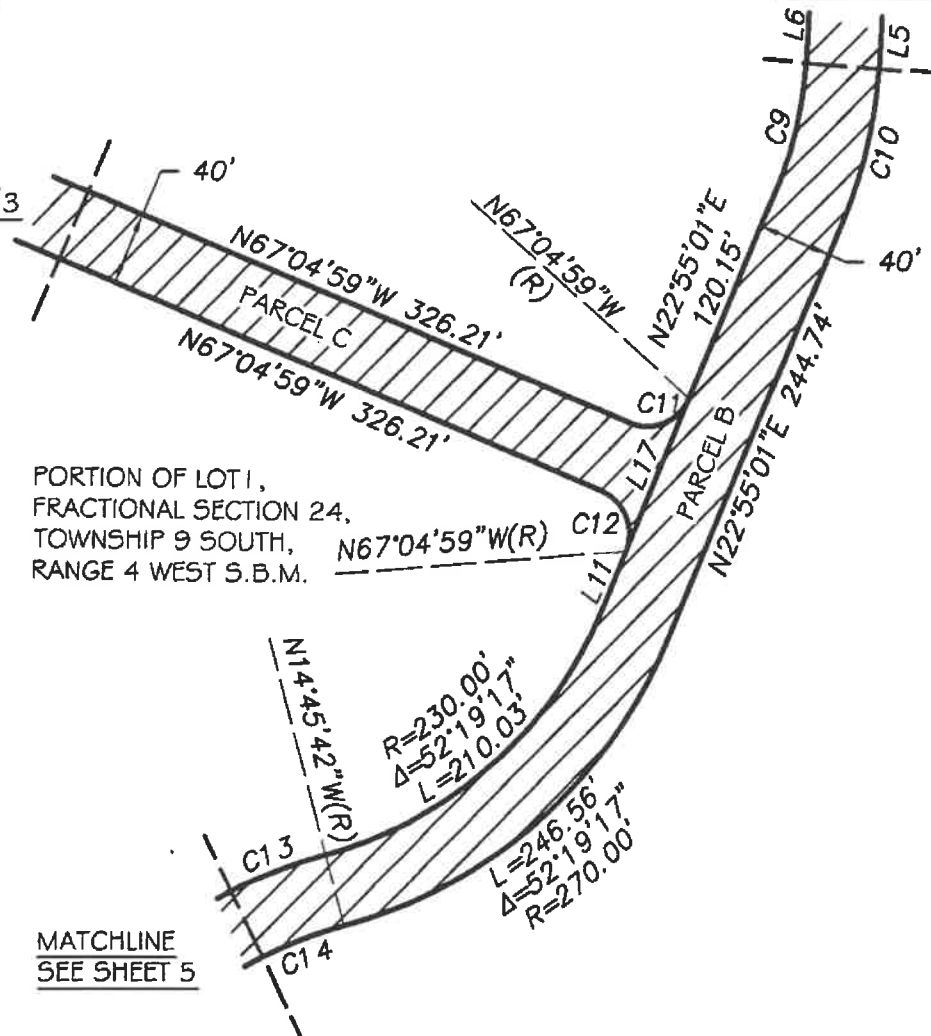

## LEGEND

INDICATES PUBLIC UTILITIES AND  
INGRESS AND EGRESS EASEMENT  
(WIDTH VARIES) TO FALLBROOK  
PUBLIC UTILITY DISTRICT  
TOTAL AREA = 3.357 ACRES

LINE TABLE		
LINE	BEARING	DISTANCE
L11	N22°55'01"E	34.58'
L17	N22°55'01"E	90.00'

CURVE TABLE			
CURVE	LENGTH	RADIUS	DELTA
C9	75.23'	230.00'	18°44'23"
C10	88.31'	270.00'	18°44'23"
C11	39.27'	25.00'	90°00'00"
C12	39.27'	25.00'	90°00'00"
C13	57.73'	270.00'	12°15'01"
C14	49.18'	230.00'	12°15'01"

**bHA, Inc.**

5115 AVENIDA ENCINAS SUITE L  
CARLSBAD, CA. 92008 (760) 931-8700  
W.O.673-0903-400

# EXHIBIT B



SCALE 1"=100'

MATCHLINE  
SEE SHEET 3

**DETAIL 'C'**  
NTS  
EXAGGERATED FOR CLARITY

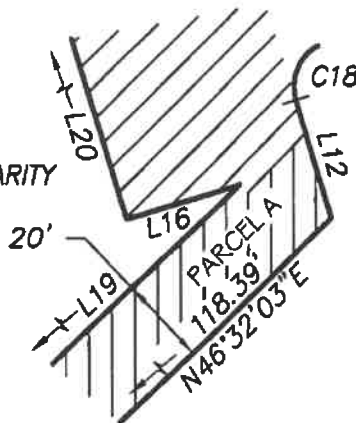

### LEGEND

INDICATES PUBLIC UTILITIES AND INGRESS AND EGRESS EASEMENT (WIDTH VARIES) TO FALLBROOK PUBLIC UTILITY DISTRICT  
TOTAL AREA = 3.357 ACRES

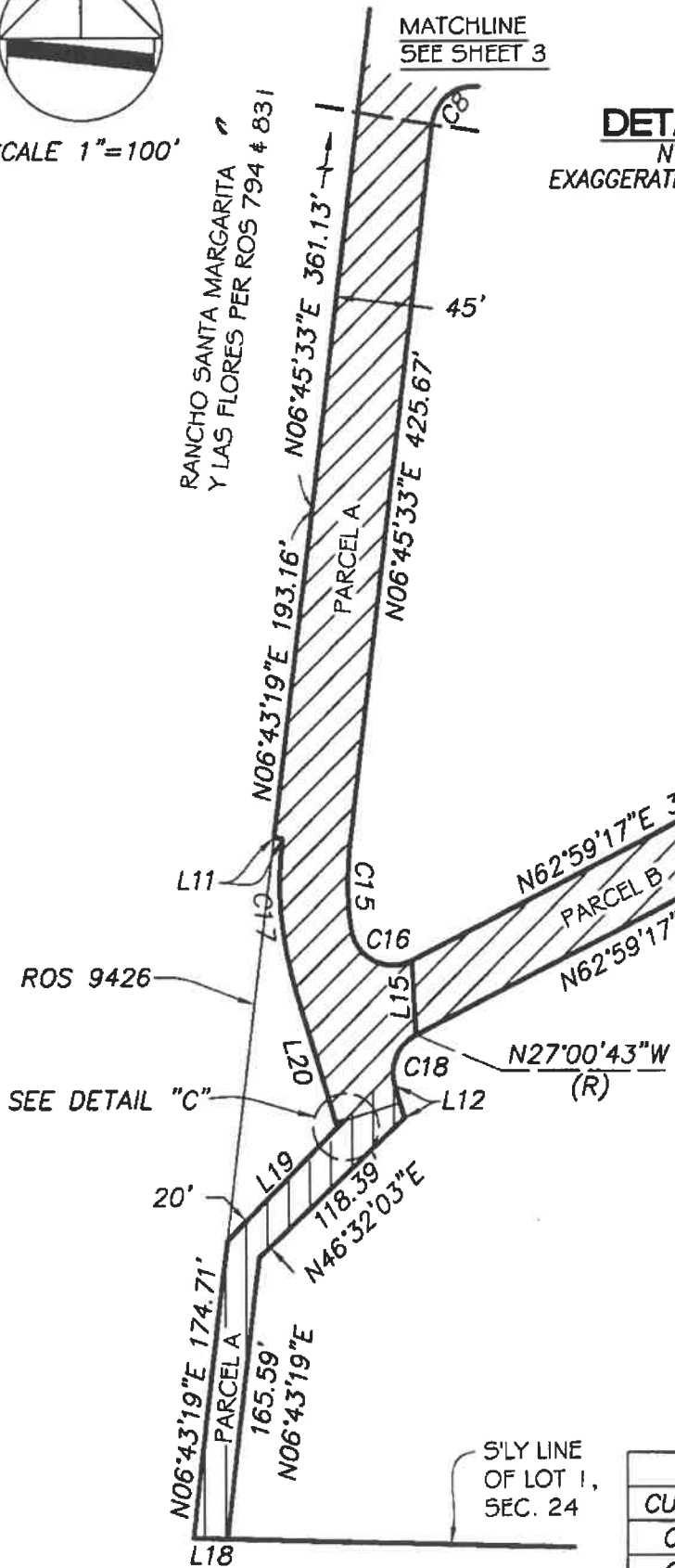

LINE TABLE		
LINE	BEARING	DISTANCE
L11	N83°16'41"W	4.92'
L12	N17°00'43"W	19.43'
L13	N54°57'35"E	90.02'
L14	N06°45'33"E	90.00'
L15	N03°20'09"W	43.68'
L16	N72°59'17"E	5.10'
L17	N22°55'01"E	90.00'
L18	N88°39'24"W	20.09'
L19	N46°32'03"E	96.60'
L20	N17°00'43"W	83.62'

CURVE TABLE			
CURVE	LENGTH	RADIUS	DELTA
C15	48.44'	180.00'	15°25'06"
C16	47.28'	25.00'	108°21'10"
C17	91.27'	220.00'	23°46'16"
C18	34.91'	25.00'	80°00'00"

**bHA, Inc.**

5115 AVENIDA ENCINAS SUITE L  
CARLSBAD, CA. 92008 (760) 931-8700  
W.O.673-0903-400

GIS



**M E M O**

**TO:** Board of Directors  
**FROM:** Jack Bebee, General Manager  
**DATE:** February 22, 2021  
**SUBJECT:** Consider Letter of Support for HR 535/S.91 (Special Districts Provide Essential Services Act) & AB 361 (Rivas) – Remote Meetings During Declared Emergencies.

---

Purpose

To request the Board's approval of a letter supporting HR 535/S.91 (Special Districts Provide Essential Services Act) & AB 361 (Rivas) – Remote Meetings During Declared Emergencies.

Summary

The California Special District's Association has requested support for HR 535/S. 91 and AB 361 (Rivas).

HR 535/S. 91, the Special Districts Provide Essential Services Act, and its inclusion in any potential pandemic relief package would ensure that constituents receiving essential services from a special district, rather than a city or county, are not excluded from future COVID-19 relief approved for state and local governments.

AB 361 would allow local agencies to safely meet remotely during an emergency. The changes to law included in AB 361 are what have allowed local agencies to continue to operate while also complying with important public health directives issued by officials during the COVID-19 pandemic; by enshrining these provisions in statute, this bill ensures that local agencies would continue to be able to remain safe in future emergencies that threaten public health.

The draft letter of support for HR 535/S.91 has been included for the Board's information as Attachment A. The draft letter of support for AB 361 (Rivas) has been included for the Board's information as Attachment B.

Budgetary Impact

There is no budgetary impact

Recommended Action

The Board authorize letters supporting HR 535/S.91 (Special Districts Provide Essential Services Act) & AB 361 (Rivas) – Remote Meetings During Declared Emergencies and direct staff to distribute the letter of support to the District's legislators.



990 East Mission Road  
 Fallbrook, California  
 92028-2232  
[www.fpud.com](http://www.fpud.com)  
 (760) 728-1125

Board of Directors

Dave Baxter  
*Division 1*

Ken Endter  
*Division 2*

Jennifer DeMeo  
*Division 3*

Don McDougal  
*Division 4*

Charley Wolk  
*Division 5*

Staff

Jack Bebee  
*General Manager*

David Shank  
*Assistant General Manager/  
 Chief Financial Officer*

Lauren Eckert  
*Executive Assistant/  
 Board Secretary*

General Counsel

Paula de Sousa  
*Best Best & Krieger*

February XX, 2021

The Honorable Dianne Feinstein  
 United States Senate  
 331 Hart Senate Office Building  
 Washington, D.C. 20510

The Honorable Alex Padilla  
 United States Senate  
 B03 Russell Senate Office Building  
 Washington, D.C. 20510

The Honorable Darrell Issa  
 United States House of Representatives  
 2300 Rayburn House Office Building  
 Washington, D.C. 20515

**RE: Support H.R. 535 and S. 91, the Special Districts Provide Essential Services Act**

Dear Senator Feinstein, Senator Padilla, and Representative Issa:

The Fallbrook Public Utility District respectfully requests your support of H.R. 535 and S. 91, the Special Districts Provide Essential Services Act, and its inclusion in any potential pandemic relief package. These bills would ensure that your constituents receiving essential services, like fire protection, water, wastewater, childcare, healthcare, resource and agricultural conservation, and more from a special district, rather than a city or county, are not excluded from future COVID-19 relief approved for state and local governments.

As a provider of water and wastewater services 35,000 of your constituents in Fallbrook, California, access to federal relief resources would help our district confront COVID-19 and overcome the pandemic’s fiscal impacts. **Our employees are on the front-lines, yet our local government agency has yet to receive the direct access to funding that other government agencies, as well as businesses and non-profits, have received.**

Our district is just one of 2,000 across the state that, altogether, anticipate a **\$1.26 billion impact** due to COVID-19 through the end of Fiscal Year 2021. Furthermore, 46 percent are unlikely to maintain current staffing of essential workers or are uncertain that they can, and 54 percent are unlikely to maintain or are uncertain about the level of essential services they can provide through this fiscal year.

These bills are identical to the bipartisan S. 4308 from the 116<sup>th</sup> Congress. H.R. 535 and S. 91 would allow the vital services that communities rely upon to continue unhindered, while also providing greater certainty for these governments to retain their essential workers. Specifically, the legislation would establish a federal definition of “special district”, allow special districts’ access to future Coronavirus Relief Fund allocations, and designate special districts as “eligible issuers” of the Federal Reserve Board’s Municipal Liquidity Facility.

Without ready access to pandemic relief available to other units of local government, the risk of special districts’ inability to continue providing uninterrupted, vital services to their communities will continue to grow. We look forward to working with you to ensure all essential workers and the vulnerable communities they serve receive equitable access to these important relief funds.

Thank you for your consideration of our request.

Sincerely,

Jennifer DeMeo  
 Board President  
 Fallbrook Public Utility District

cc: Governor Gavin Newsom, 1303 10<sup>th</sup> Street, Suite 1173, Sacramento, CA 95814  
 Cole Karr, Federal Advocacy Coordinator, California Special Districts Association  
[advocacy@cstda.net](mailto:advocacy@cstda.net)



990 East Mission Road  
Fallbrook, California  
92028-2232  
[www.fpud.com](http://www.fpud.com)  
(760) 728-1125

Board of Directors

Dave Baxter  
*Division 1*

Ken Endter  
*Division 2*

Jennifer DeMeo  
*Division 3*

Don McDougal  
*Division 4*

Charley Wolk  
*Division 5*

Staff

Jack Bebee  
*General Manager*

David Shank  
*Assistant General Manager/  
Chief Financial Officer*

Lauren Eckert  
*Executive Assistant/  
Board Secretary*

General Counsel

Paula de Sousa  
*Best Best & Krieger*

February XX, 2021

Assembly Member Robert Rivas  
California State Assembly  
State Capitol, Room 5158  
Sacramento, CA 95814  
[Julio.MendezVargas@asm.ca.gov](mailto:Julio.MendezVargas@asm.ca.gov)

**RE: Assembly Bill 361 (Rivas) – Support [As Introduced]**

Dear Assembly Member Rivas:

The Fallbrook Public Utility District is pleased to support your Assembly Bill 361, related to the Ralph M. Brown Act (“the Brown Act”). Fallbrook Public Utility District provides water and wastewater services to over 35,000 people.

In light of a stay-at-home order and the need to keep individuals physically distanced from one another, Governor Newsom issued a number of subsequent executive orders (N-25-20, N-29-20, N-35-20) modifying the requirements of the Brown Act. AB 361 seeks to codify several provisions from within the executive orders.

AB 361 would allow local agencies to safely meet remotely during an emergency. The changes to law included in AB 361 are what have allowed local agencies to continue to operate while also complying with important public health directives issued by officials during the COVID-19 pandemic; by enshrining these provisions in statute, this bill ensures that local agencies would continue to be able to remain safe in future emergencies that threaten public health.

AB 361 will include important safeguards that ensure public agency transparency and public access. For a public agency to utilize these provisions to meet remotely, a local agency must meet subsequent or concurrent to a proclaimed state of emergency or declared local emergency, and declare that the nature of the emergency would prevent them from safely meeting in-person. This bill would specifically prohibit local agencies from requiring members of the public to submit their comments in advance, guaranteeing that the public has the opportunity to observe and offer comment during the meeting.

For these reasons, Fallbrook Public Utility District is pleased to support Assembly Bill 361 (Rivas). Please feel free to contact us if you have any questions.

Jennifer DeMeo  
Board President  
Fallbrook Public Utility District

CC: The Honorable Marie Waldron  
The Honorable Brian W. Jones  
California Special Districts Association



## MEMO

**TO:** Board of Directors  
**FROM:** Jason Cavender, Operations Manager  
**DATE:** February 22, 2021  
**SUBJECT:** Engineering and Operations Key Performance Indicators

---

### Purpose

To provide information to the Board on the Key Performance Indicators (KPIs) that have been developed for Engineering and Operations.

### Summary

The primary purpose for developing and tracking KPIs is to provide a performance measurement system that gives management the ability to analyze data, make better decisions, and improve the organization. District KPIs are largely focus on Capital Improvement Projects (CIP), Preventative Maintenance (PM), leak response, and regulatory compliance.

### Recommended Action

This is an information item. No board action needed.

**This page intentionally left blank.**

M E M O

**TO:** Board of Directors  
**FROM:** Soleil Develle: Engineering Technician III  
**DATE:** February 22, 2021  
**SUBJECT:** The Fallbrook Village Association as a Community Service Water User (Vince Ross Square)

---

Purpose

To provide a Community Service Water User water allotment to the Vince Ross Square. (Meter #403, 102 S. Main Ave.)

Summary

The Vince Ross Square is located at the intersection of S. Main Ave and Alvarado St. The site is approximately 0.16 acre and currently has a ¾” water meter, basic plumbing, and landscaping. The Vince Ross Square has consistently been used as a public space and as host to various community events and services. The Fallbrook Village Association (FVA) is requesting that the Board establish the Vince Ross Square as a Community Service Water User, and grant an allotment of water to be utilized as a community benefit for no charge. Monthly charges and other fees will still apply.

Any water used beyond the agreed upon allotment would be billed at the standard “Irrigation Only” rate per 1,000 gallons. (Currently \$7.04/unit)

Budgetary Impact

<b>Community Service Water User</b>	<b>District Allotment (Annual)</b>	<b>Approximate District Cost (Annual)</b>
Vince Ross Square (FVA)	Water (1/2 Acre Feet)	\$1,147

Staff has reviewed the request of 1/2 acre feet per year for the Vince Ross Square, and has found this to be an appropriate allotment, based on the maximum historical usage.

Recommendation

Staff supports the Board’s direction. If approved, staff will provide an update on water usage at the end of each fiscal year.

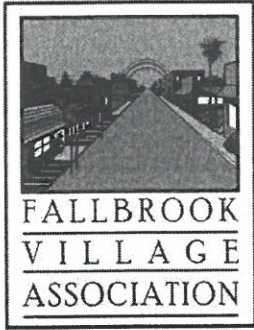

*The mission of the **Fallbrook Village Association** is to promote and support the economic, physical and cultural revitalization of the Fallbrook area.*

a 501 c(3) Non-Profit Organization  
P.O. Box 2438  
Fallbrook, Ca. 92088  
EIN 26-1126751  
**760-723-8384**

To: Jack Bebee

Re: Water at the Village Square

The Village Square has served our community for over 25 years as a: town center park, an event center, and a Veteran's Memorial.

On behalf of the Fallbrook Village Association, I am requesting that FPUD donate the water that helps with our maintenance of the square.

Vincent Ross

A handwritten signature in blue ink, consisting of a stylized 'V' followed by a long horizontal stroke.

Vice President

## M E M O

**TO:** Board of Directors  
**FROM:** Jack Bebee, General Manager  
**DATE:** February 22, 2021  
**SUBJECT:** Authorization for Additional Deposit to San Diego Local Agency Formation Commission

---

Description

San Diego Local Agency Formation Commission (SDLAFCO) is moving forward on processing the District's application for reorganization to detach from the San Diego County Water Authority (SDCWA) and annex into Eastern Municipal Water District (EMWD), to reduce the wholesale cost of water and its associated rate impacts to the District's customers ("Application"). SDLAFCO has hired a consultant (Dr. Hanemann) to evaluate three issues relative to the detachment:

1. Water Supply Reliability
2. Financial Impact
3. Any Potential departure cost

Funding for processing the Application by SDLAFCO including any consultants is paid by the applicant, in this case the District. The District provided an initial deposit of \$24,563 and an additional \$62,220 in August 2020 to pay for SDLAFCO staff costs. The SDLAFCO Executive Officer is requesting an additional deposit of \$50,000 to pay for the work to be completed by Dr. Hanemann. SDLAFCO staff does not anticipate any additional costs at this time for LAFCO staff to process the Application.

Budgetary Impact

Staff did anticipated some additional Application processing costs and that were included in the adopted budget. Staff will continue to work with SDLAFCO to ensure that the funds are spent on topics directly relevant to the Application process and that the process continues to make constructive progress towards ultimate approval of detachment from SDCWA and annexation into EMWD. If the Application is approved there will be a long-term reduction in the cost of purchased water estimated to be over 25%, which is estimated to save District ratepayers millions of dollars a year.

Recommended Action

That the Board authorize the General Manager to provide an additional deposit to SDLAFCO of \$50,000.

**M E M O**

**TO:** Board of Directors  
**FROM:** Engineering & Operations Committee  
**DATE:** February 22, 2021  
**SUBJECT:** SMRCUP Change Order - GAC Treatment Installation & Pipeline Alignment Changes

---

Description

Change order for the installation of GAC treatment system and changes to the pipeline alignment for the SMRCUP construction contract.

Purpose

Design and installation of additional treatment to the SMRCUP facilities to treat RO bypass flows was approved in January 2020. Granular Activated Carbon (GAC) treatment was identified as the best option to remove a wide range of potential emerging contaminants. This, coupled with the RO treatment, will provide the best available groundwater treatment technology. A contract to procure the GAC treatment equipment from Calgon Carbon was approved in December 2020. District Staff and the District's contracted Construction Manager have worked with the project contractor, Filanc-Alberici, to negotiate a change order for the installation and startup of this equipment at a cost of \$3,064,873. The intent is for the contractor to incorporate this change into the existing schedule. However, due to potentially long lead times on the GAC vessels, the pumps, and the electrical control gear, there is a chance this component of the project will be completed after the rest of the treatment plant is commissioned.

The change order also incorporates \$324,928 for changes to the pipeline design and installation required by field and existing utility conflicts.

Budgetary Impact

The necessary funds will come from both the approved loan contingency as well as the SRF Loan Agreement amendment currently under review by the state administrators.

Recommended Action

The Board approve the change order for Filanc-Alberici to complete the additional work at a cost of \$3,389,801.

**CHANGE ORDER NUMBER 003**

**NAME OF PROJECT:** Santa Margarita Conjunctive Use Project

**CONTRACTOR:** Filanc Alberici a Joint Venture  
740 N Andreasen Drive  
Escondido, CA 92029

Original CONTRACT AMOUNT .....	\$54,398,232.00
Previous CHANGE ORDERS .....	\$559,145.00
Current CONTRACT PRICE .....	\$54,957,377.00
Amount of this CHANGE ORDER .....	\$3,389,801.00
New CONTRACT PRICE .....	\$58,347,178.00
Original COMPLETION Date .....	September 13, 2021
Time ADDED due to Previous CHANGE ORDERS.....	0 CALENDAR DAYS
Time ADDED due to this CHANGE ORDER .....	TBD*
New FINAL COMPLETION Date .....	TBD*

\*See Schedule Section Below and Exhibit B

This Change Order constitutes full and final settlement for all direct costs, including but not limited to, all labor, design, equipment, material, mark-ups, and time associated with performing the work described herein. This document will become a supplement to the Contract and all Contract provisions will apply hereto. The Change Order will become effective when approved by the Fallbrook Public Utility District. By accepting this Change Order, the Contractor waives the right to make any additional claim for any item related to these changes.

The following changes are hereby made to the CONTRACT DOCUMENTS:

**Item 1 – Contract Addition of PFAS System Installation Scope of Work:**

Background:

On September 11, 2020 - the 90% PFAS Design Documents were transmitted to FAJV and a request was made to submit pricing for the construction and installation of the PFAS GAC system and supporting infrastructure.

Proposal:

This proposal includes all direct labor, material, equipment, taxes and price escalation associated with the construction of the PFAS pump station and GAC tank farm as submitted under FAJV PCO-118:

1. All Site/Civil work including buried yard piping and leveling the immediate site/work.
2. Excavation of all footings and structural mat slabs.
3. Form/Reinforce/Pour/Finish slabs + layout/installation of anchor bolts
4. Design/Supply/Install of all pipe supports
5. Supply and install of (4) PFAS Supply Pumps
6. Supply and install lot of valves and piping
7. Installation of Owner Furnished GAC (6) tanks, (3) manifolds and associated piping

Contract Document Modifications:

ADD: 90% PFAS Drawings (Dated Sep 2020)

- General: G-1, G-2, G-3, G-4, G-5, G-6, G-7
- Civil: C-1, C-2, CD-1, CD-2
- Mechanical: 900M-1, 900M-2, 900M-3, 900M-4, MD-1, MD-2
- Structural: 900S-1, 900S-2, 900S-3, 900S-4
- Electrical: GE-1, GE-2, GE-3, GE-4, GE-5, GE-6, 400E-1, 900E-1, 900E-2
- Instrumentation: GI-1, 900I-1, 900I-2
- ADD: 90% PFAS Specifications (Dated September 2020)
  - 01010 - PFAS Summary of Work (90%)
  - 01115 - PFAS MOFO (90%)
  - 01630 - Placing PFAS Equip in Operation (90%)
  - 01660 - PFAS Equip Testing & Start-Up (90%)
  - 11306 - PFAS Horiz End Suction (90%)
  - 15041 - PFAS Clean-Test-Disin (90%)
  - 15062 - PFAS Steel Pipe (90%)
  - 15100 - PFAS Valves (Non-Owner) (90%)
  - 17010 - PFAS I&C (General) (90%)
  - 17330 - PFAS Process Control Descriptions (90%)

Exclusions/Clarifications:

See Exhibit A – FAJV Exclusions and Clarifications included within this Change Order.

Schedule:

Included in this change is a preliminary PFAS installation schedule, developed by the Contractor, to become the baseline schedule for this scope of work (see Exhibit B). As such, the schedule indicates a Final Completion Date of February 14, 2022, which amounts to Time Added due to this Change Order of 126 calendar days.

The Owner and the Contractor have agreed to proceed with the PFAS system installation without finalizing a New Final Completion Date for the PFAS System Installation and without adjusting the Contract Price for extended general conditions for the estimated additional 125 calendar days at this time. The Owner agrees that the Contractor and its Subcontractors are entitled to Extended General Conditions for the additional PFAS installation scope of work but desires to compensate Contractor in accordance with the rates established in Exhibit C for time beyond October 12, 2021. Both parties agree to work together to mitigate schedule impacts associated with long lead procurement items.

Filanc Alberici a Joint Venture reserve all rights under the Contract. In addition to the items listed above, Filanc Alberici a Joint Venture reserves the rights to seek additional compensation or schedule relief relating to events, conditions and changes related to the additional work that is unforeseeable or not yet ascertainable.

CHANGE TO CONTRACT AMOUNT	\$3,064,873.00
TIME EXTENSION	TBD*

Perform all work in accordance with the Contract Documents.



**Item 2 – 24” Pipeline Alignment Changes:**

Field conflicts discovered during pre-construction and construction activities on the 24” Pipeline between the treatment plant and McDonald Road required alignment revisions and additional excavation/construction effort. Actual cost and quantity impacts were tracked during installation. This item includes those costs, with detailed records attached in PCO-022 and PCO-034.

CHANGE TO CONTRACT AMOUNT  
TIME EXTENSION

\$324,928.00  
0 Calendar Days

Perform all work in accordance with the Contract Documents.

**CONTRACTOR: Filanc Alberici a Joint Venture**

**By:** \_\_\_\_\_

**Date:** \_\_\_\_\_

**Name:**

**Title:**

**RECOMMENDATION AND CONCURRENCE**

**FALLBROOK PUBLIC UTILITY DISTRICT:**

**By:** \_\_\_\_\_

**Date:** \_\_\_\_\_

**Name:**

**Title:**

## M E M O

**TO:** Board of Directors  
**FROM:** Jack Bebee, General Manager  
**DATE:** February 22, 2021  
**SUBJECT:** Adoption of Resolution No. 5006, Updating the Administrative Code Table of Contents, Renumbering of Existing Articles to Create a Sequential Order, and Updating Internal Section Cross-References as Necessary

---

Description

For the Board to consider updates to the Administrative Code Table of Contents, renumbering of existing Articles, and updating internal section cross-references as necessary.

Purpose

Throughout the past year, the District's Administrative Code has been reviewed and Articles have been amended, including the repeal of several articles. Because of these updates and repeals, there are several Article numbers no longer in use. Therefore, Resolution No. 5006, if approved, will re-number the existing Administrative Code Article numbers. This is a non-substantive amendment to the Administrative Code, and only includes the re-numbering of existing Articles to create a sequential order, and update internal section cross-references as necessary.

Budgetary Impact

There is no budgetary impact.

Recommended Action

That the Board adopt Resolution No. 5006, amending the Administrative Code Table of Contents, and renumbering Administrative Code Articles to create a sequential order, and update internal section cross-references as necessary.

**Attachment A**  
**Existing Administrative Code Table of Contents**

**FALLBROOK PUBLIC UTILITY DISTRICT  
ADMINISTRATIVE CODE  
INDEX**

**ARTICLE 1           GENERAL PROVISION**

- Sec. 1.1           Purpose
- Sec. 1.2           Adoption
- Sec. 1.3           Changes

**ARTICLE 2           BOARD OF DIRECTORS, GUIDELINES FOR**

- Sec. 2.1           Powers - Delegation
- Sec. 2.2           Officers of Board of Directors
  - 2.2.1           Election of Officers
  - 2.2.2           Duties of President
  - 2.2.3           Duties of Vice President
- Sec. 2.3           Other Officers of the District
- Sec. 2.4           Employment of Professionals
  - 2.4.1           General Counsel
  - 2.4.2           Auditor
- Sec. 2.5           Time and Place of Board Meetings
- Sec. 2.6           Special Meetings
- Sec. 2.7           Quorum
- Sec. 2.8           Actions
- Sec. 2.9           Order of Procedure of Meetings
- 2.9.1           Guidelines for Conduct of Board Meetings
- Sec. 2.10          Consent Calendar
- Sec. 2.11          Minutes
- Sec. 2.12          Directors' Compensation
- Sec. 2.13          Board Packets
- Sec. 2.14          Board Committees
- Sec. 2.15          Ethics Policy
- Sec. 2.16          Comprehensive Code of Conduct
  - 2.16.1          Purposes and Goals of Code of Conduct
  - 2.16.2          Minimum Expectations for Conduct of Board Meetings
  - 2.16.3          Breaches of Order at Meetings; Sanctions
  - 2.16.4          Violations of Board Policies or Law Outside of Board Meetings
  - 2.16.5          Sanctions
  - 2.16.6          Authority of Administration to Provide for Security
  - 2.16.7          Board Orientation and Training
- Sec. 2.17          Directors Expenses Incurred on District Business
  - 2.17.1          Directors and Meetings
  - 2.17.2          Prepayment of Otherwise Reimbursable Expenses
  - 2.17.3          Reimbursement of Expenses
  - 2.17.4          Meals and Lodging
  - 2.17.5          Entertainment
  - 2.17.6          Incidental Expenses
  - 2.17.7          Director's Responsibility
  - 2.17.8          Reports
  - 2.17.9          Penalties

[\\* As of February 2021, the Board of Directors adopted Resolution 5006, and the Table of Contents was renumbered to remove unused articles and make existing articles sequential.](#)

- 2.17.10 Ethics Training
- Sec. 2.18 Gifts and Disclosure
- 2.18.1 Annual Disclosure of Reimbursements
- 2.18.2 Prohibition against Acceptance of Honorarium
- 2.18.3 Permissible Gifts May Not Exceed \$500.00
- 2.18.4 Penalties for Violations
- Cal Pen Code 403 (Appendix A)
- Cal Gov Code 3060 (Appendix B)

**ARTICLE 3 CONFLICT OF INTEREST CODE**  
~~Designated Users (Appendix A)~~ **(Repealed Feb. 27, 2017)**

**ARTICLE 4 PERSONNEL**

- Sec. 4.1 General Manager
- Sec. 4.2 Memoranda of Understanding
- Sec. 4.3 Personnel Regulations
- Sec. 4.4 Expense Reimbursement and Code of Conduct
- 4.4.1 Expenses Incurred on District Business
- Sec. 4.5 Code of Conduct
- 4.5.1 General Rule with Respect to Conflicts of Interest
- 4.5.2 Acceptance of Gifts, Gratuities or Benefits
- 4.5.3 Actions and Conduct Designed to Build Public Confidence
- 4.5.4 Use of Confidential Information
- 4.5.5 Use of District Employment and Facilities for Private Gain
- 4.5.6 Contracts with the District
- 4.5.7 Personal Investments
- 4.5.8 Behavior in the Workplace
- 4.5.9 Ethics and Sexual Harassment Avoidance Training
- Sec. 4.6 Memberships in Professional Organizations

~~**ARTICLE 5 ADMINISTRATIVE SERVICES MANAGER DUTIES**~~  
~~(Repealed in its Entirety Apr. 27, 2020)~~

~~**ARTICLE 6 HUMAN RESOURCES MANAGER DUTIES**~~  
~~(Repealed in its Entirety Apr. 27, 2020)~~

~~**ARTICLE 7 PUBLIC AFFAIRS SPECIALIST DUTIES**~~  
~~(Repealed in its Entirety Apr. 27, 2020)~~

~~**ARTICLE 8 ENGINEERING DEPARTMENT DUTIES**~~  
~~(Repealed in its Entirety Apr. 27, 2020)~~

~~**ARTICLE 9 WATER DISTRIBUTION & WASTEWATER**~~  
~~**COLLECTION SYSTEMS DUTIES**~~  
~~(Repealed in its Entirety Apr. 27, 2020)~~

\* As of February 2021, the Board of Directors adopted Resolution 5006, and the Table of Contents was renumbered to remove unused articles and make existing articles sequential.

- Formatted: Indent: Hanging: 0.5"
- Formatted: Normal, Indent: Left: 0", Hanging: 0.5",  
Line spacing: Exactly 12 pt
- Formatted: Indent: Left: 0", Hanging: 0.5"
- Formatted: Indent: Hanging: 0.5"
- Formatted: Indent: Left: 0", Hanging: 0.5"
- Formatted: Indent: Left: 0.5", First line: 0"
- Formatted: Indent: Hanging: 0.5"
- Formatted: Indent: Left: 0", Hanging: 0.5"
- Formatted: Indent: Hanging: 0.5"
- Formatted: Indent: Left: 0", Hanging: 0.5"
- Formatted: Indent: Left: 0.5", First line: 0"
- Formatted: Normal, Indent: Left: 0", Hanging: 0.5",  
Line spacing: Exactly 12 pt
- Formatted: Indent: Hanging: 0.5"

~~ARTICLE 10 SECRETARY DUTIES~~  
(Repealed in its Entirety Apr. 27, 2020)

~~ARTICLE 11 PERSONNEL REGULATIONS & CIVIL SERVICE RULES~~  
(Repealed in its Entirety Apr. 27, 2020)

~~ARTICLE 12 STAFF, GUIDELINES FOR~~  
(Repealed in its Entirety Apr. 27, 2020)

~~ARTICLE 13 MEMBERSHIPS, PROFESSIONAL/TECHNICAL ORG.~~  
(Repealed in its Entirety Apr. 27, 2020)

**ARTICLE 14.5 DISTRICT PROCUREMENT PROCEDURES (Renumbered from previous Article 14)**

- Sec. 14.5.1 Authority
- Sec. 14.5.2 General
- Sec. 14.5.3 Procurement Philosophy
- Sec. 14.5.4 Definitions
- Sec. 14.5.5 Procedures for the Purchase of Public Projects, Maintenance, and Articles
- Sec. 14.5.6 Procedures for Procurement of Professional Services
- Sec. 14.5.7 Prequalification
- Sec. 14.5.8 Emergencies
- Sec. 14.5.9 Exceptions to Procurement Requirements
- Sec. 14.5.10 Local Procurements
- Sec. 14.5.11 Sale of Surplus Property/Equipment and Scrap Metal
- Sec. 14.5.12 Use of District Credit Card
- Sec. 14.5.13 Contract Amendment Procedures

**ARTICLE 15.6 BUDGET AND FUND MANAGEMENT (Renumbered from previous Article 15)**

- Sec. 15.6.1 District's Annual Budget
- 15.6.1.1 Annual Budget Resolution
- Sec. 15.6.2 Treasurer's Fund
- Sec. 15.6.3 General Fund
- Sec. 15.6.4 Utility Funds
- Sec. 15.6.5 Capital Funds
- Sec. 15.6.6 Equipment Fund
- Sec. 15.6.7 Debt Service Funds
- Sec. 15.6.8 Appropriated Fund Balances
- 15.6.8.1 Utility Funds Appropriated Fund Balances
- 15.6.8.2 Utility Capital Funds Appropriated Fund Balances
- 15.6.8.3 Debt Service Funds
- Sec. 15.6.9 Petty Cash

\* As of February 2021, the Board of Directors adopted Resolution 5006, and the Table of Contents was renumbered to remove unused articles and make existing articles sequential.

Formatted: Indent: Left: 0", Hanging: 0.5", Line spacing: Exactly 12 pt

Formatted: Indent: Left: 0", Hanging: 0.5"

Formatted: Indent: First line: 0"

Formatted: Indent: Hanging: 0.5"

Formatted: Indent: Left: 0", Hanging: 0.5"

Formatted: Indent: Hanging: 0.5"

Formatted: Indent: Left: 0", Hanging: 0.5"

Formatted: Indent: Hanging: 0.5"

Formatted: Indent: Left: 0", Hanging: 0.5"

Formatted: Indent: Left: 0.5", First line: 0"

Formatted: Indent: Hanging: 0.5"

**ARTICLE ~~16~~ 7A**     **INSURANCE CLAIMS HANDLING PROCEDURES (JPIA)**  
**(Renumbered from previous Article 16A)**

- Sec. ~~16~~ 7A.1            General
- Sec. ~~16~~ 7A.2            General Handling Procedures
- ~~16~~ 7A.2.1            Rejection of Sufficient and Timely Claims
- ~~16~~ 7A.2.2            Rejection of Insufficient and Late Claims
- ~~16~~ 7A.2.3            Late Claims
- Sec. ~~16~~ 7A.3            Small Claims Settlement Option

**ARTICLE ~~16~~ 7B**     **INSURANCE CLAIMS HANDLING PROCEDURES (DISTRICT-**  
**GOVERNMENT CODE 905) (Renumbered from previous Article**  
**16B)**

- Sec. ~~16~~ 7B.1            General
- Sec. ~~16~~ 7B.2            Claims Time Limitations
- Sec. ~~16~~ 7B.3            Claims Required
- Sec. ~~16~~ 7B.4            Form of Claim
- Sec. ~~16~~ 7B.5            Claim Prerequisite to Suit
- Sec. ~~16~~ 7B.6            Suit
- Sec. ~~16~~ 7B.7            Severability

**ARTICLE ~~17~~ 8**     **DISTRICT INSPECTIONS BY A REGULATORY AGENCY**  
**(Renumbered from previous Article 17)**

- Sec. ~~17~~ 8.1            General
- Sec. ~~17~~ 8.2            Purpose
- Sec. ~~17~~ 8.3            Scope
- Sec. ~~17~~ 8.4            Responsibilities
- Sec. ~~17~~ 8.5            Procedures

**ARTICLE ~~18~~ 9**     **ANNEXATIONS (Renumbered from previous Article 18)**

- Sec. ~~18~~ 9.1            Incorporation by Reference
- Sec. ~~18~~ 9.2            General
- Sec. ~~18~~ 9.3            Annexation Payments
- Sec. ~~18~~ 9.4            Conditions for Annexation
- Sec. ~~18~~ 9.5            1950 Annexation
- Sec. ~~18~~ 9.6            1958 Annexation
- Sec. ~~18~~ 9.7            Airpark Annexation
- Sec. ~~18~~ 9.8            Red Mountain Ranch Annexation
- Sec. ~~18~~ 9.9            DeLuz Annexation
- Sec. ~~18~~ 9.10            Annexation/Detachments between Adjacent Districts
- Sec. ~~18~~ 9.11            Partial Annexations
- Sec. ~~18~~ 9.12            DeLuz Service Area Annexations
- ~~18~~ 9.12.1            Additional Costs
- Sec. ~~18~~ 9.13            Improvement District "S"
- ~~18~~ 9.13.1            Annexation Fees and Costs
- ~~18~~ 9.13.2            Adjustment Review

**ARTICLE ~~19~~ 10**     **WATER SERVICE CONNECTIONS AND RULES FOR**  
**DELIVERY OF WATER (Renumbered from previous Article 19)**

\* As of February 2021, the Board of Directors adopted Resolution 5006, and the Table of Contents was renumbered to remove unused articles and make existing articles sequential.



Sec. <del>19</del> 10.1	Definitions
Sec. <del>19</del> 10.2	Remote Meter Agreements
Sec. <del>19</del> 10.3	Temporary Service Agreements
Sec. <del>19</del> 10.4	Engineering Fees
<del>19</del> 10.4.1	Plan Check Fees
<del>19</del> 10.4.2	Fees for District to Inspect Contractor Installed Facilities
Sec. <del>19</del> 10.5	Rules for Service of Water
Sec. <del>19</del> 10.6	Meter and Service Line Installations
Sec. <del>19</del> 10.7	Meter Relocation Fees
Sec. <del>19</del> 10.8	Connection/Capacity Fees
<del>19</del> 10.8.1	Replacement of Removed Meters
<del>19</del> 10.8.2	Meter Testing Costs
<del>19</del> 10.8.3	Adjustment to Fees for Meters and Connections
Sec. <del>19</del> 10.9	Credit for Connection Fees and Fees for Increased Meter Size
Sec. <del>19</del> 10.10	San Diego County Water Authority Connection Fees
Sec. <del>19</del> 10.11	San Diego County Water Authority Permanent Special Agricultural Water Program Administration
<del>19</del> 10.11.1	Purpose
<del>19</del> 10.11.2	Qualification
<del>19</del> 10.11.3	Certification and Recertification
<del>19</del> 10.11.4	Acknowledgement
<del>19</del> 10.11.5	Exit and Re-entry into the PSAWR
<del>19</del> 10.11.6	Implementation of Mandatory PSAWR Supply Reductions
Sec. <del>19</del> 10.12	Installation or Extension Line Costs
Sec. <del>19</del> 10.13	Customer Valve
Sec. <del>19</del> 10.14	Water Must Pass Through Meter
Sec. <del>19</del> 10.15	Mains, Service Pipes, Equipment Belonging to District
Sec. <del>19</del> 10.16	Meter Area Clean and Consumer Line Free from Leaks
Sec. <del>19</del> 10.17	Fires
Sec. <del>19</del> 10.18	Access to Meters
Sec. <del>19</del> 10.19	Temporary Discontinuance of Service for Repairs, etc.
Sec. <del>19</del> 10.20	Allowances or Rebates
Sec. <del>19</del> 10.21	Water Served to Others
Sec. <del>19</del> 10.22	Backflow Prevention Devices
<del>19</del> 10.22.1	Type of Backflow Protection Required
<del>19</del> 10.22.2	Backflow Device Installation on New Services
<del>19</del> 10.22.3	Reduced Pressure Backflow Preventer Retrofits
<del>19</del> 10.22.4	Reduced Pressure Backflow Preventer Device Retrofit – Installed by Property Owner
<del>19</del> 10.22.5	Well Destruction and Alteration
Sec. <del>19</del> 10.23	Booster Pumps
<del>19</del> 10.23.1	Fallbrook Service Area Pressure Zones
<del>19</del> 10.23.2	DeLuz Heights Service Area Pressure Zones
Sec. <del>19</del> 10.24	Fire Hydrants
Sec. <del>19</del> 10.25	Automatic Sprinkler and Fire Protection Systems
Sec. <del>19</del> 10.26	Construction Meters
Sec. <del>19</del> 10.27	Water Used for Annual Crops
Sec. <del>19</del> 10.28	Illegal Use of Water
Sec. <del>19</del> 10.29	Water Service Outside District
Sec. <del>19</del> 10.30	Application of Water Service to Affordable Housing
<del>19</del> 10.30.1	Review of Service Policies

\* As of February 2021, the Board of Directors adopted Resolution 5006, and the Table of Contents was renumbered to remove unused articles and make existing articles sequential.

Sec. ~~19~~ 10.31 Administrative Fees

**ARTICLE ~~20~~ 11 SEWER SERVICE REQUIREMENTS AND FEES (Renumbered from previous Article 20)**

- Sec. ~~20~~ 11.1 Definitions
- Sec. ~~20~~ 11.2 Prohibited Connections
- Sec. ~~20~~ 11.3 Prohibited Uses and Prohibited Discharges
- Sec. ~~20~~ 11.4 Permit Required
- Sec. ~~20~~ 11.5 Sewer Permit Application Process
  - ~~20~~ 11.5.1 Submission of Application
  - ~~20~~ 11.5.2 Determination of Equivalent Dwelling Unit and Strength
  - ~~20~~ 11.5.3 Payment of Fees
- Sec. ~~20~~ 11.6 Sewer Availability Forms and Letters
- Sec. ~~20~~ 11.7 Equivalent Dwelling Unit Schedules
- Sec. ~~20~~ 11.8 Determination and Classification of Strength (BOD and SS)
- Sec. ~~20~~ 11.9 Sewer Use Permits
- Sec. ~~20~~ 11.10 Temporary Sewer Service Agreement
- Sec. ~~20~~ 11.11 Permit Modifications
- Sec. ~~20~~ 11.12 Permits Non-Transferable
- Sec. ~~20~~ 11.13 Application of Sewer Service to Affordable Housing
- Sec. ~~20~~ 11.14 Sewer Use Requirements
  - ~~20~~ 11.14.1 General Conditions for Sewage Disposal
  - ~~20~~ 11.14.2 Discharge Prohibition
  - ~~20~~ 11.14.3 FOG Compliance Program
- Sec. ~~20~~ 11.15 Miscellaneous Provisions
  - ~~20~~ 11.15.1 Provide Information
  - ~~20~~ 11.15.2 Users Outside the District
  - ~~20~~ 11.15.3 Agreements
- Sec. ~~20~~ 11.16 Fees and Charges
  - ~~20~~ 11.16.1 Sewer Service Charges
  - ~~20~~ 11.16.2 Capacity Fees
  - ~~20~~ 11.16.3 Plan Check Fees
  - ~~20~~ 11.16.4 Lateral Fees
  - ~~20~~ 11.16.5 Fees for District to inspect Contractor-Installed Facilities
  - ~~20~~ 11.16.6 Annexation Fees
  - ~~20~~ 11.16.7 Fees and Charges May Be Collection with Taxes
- Sec. ~~20~~ 11.17 Right of Entry and Inspection
- Sec. ~~20~~ 11.18 Enforcement – Generally
- Sec. ~~20~~ 11.19 Administrative Enforcement
  - ~~20~~ 11.19.1 Monitoring
  - ~~20~~ 11.19.2 Citations
  - ~~20~~ 11.19.3 Termination of Service and Revocation of Permit
  - ~~20~~ 11.19.4 Permit Amendment
  - ~~20~~ 11.19.5 Cost Recovery
  - ~~20~~ 11.19.6 Administrative Compliant – Pretreatment Violations
- Sec. ~~20~~ 11.20 Public Nuisance
- Sec. ~~20~~ 11.21 Civil Enforcement
  - ~~20~~ 11.21.1 Injunction
  - ~~20~~ 11.21.2 Other Actions
  - ~~20~~ 11.21.3 Criminal Enforcement
- Sec. ~~20~~ 11.22 Appeal Process
  - ~~20~~ 11.22.1 Appeals of Determinations and Redeterminations of EDUs

\* As of February 2021, the Board of Directors adopted Resolution 5006, and the Table of Contents was renumbered to remove unused articles and make existing articles sequential.

- ~~20~~ 11.22.2 Appeals of Special Use Permit Requirements
- ~~20~~ 11.22.3 Appeals of Administrative Enforcement Actions
- ~~20~~ 11.22.4 Hearing on Appeal
- ~~20~~ 11.22.5 Appeal to Board
- ~~20~~ 11.22.6 Judicial Review
- Sec. ~~20~~ 11.23 Delivery of Notice

**ARTICLE ~~21~~ 12 WATER AND SEWER RATES AND SERVICE CHARGES**  
**(Renumbered from previous Article 21)**

- Sec. ~~21~~ 12.1 Volumetric Water, Recycled Water, and Pumping Rates
- Sec. ~~21~~ 12.2 Monthly Fixed Charges
- Sec. ~~21~~ 12.3 MWD Readiness-to-Serve Charge (RTS) and San Diego County Water Authority Infrastructure Access Charge (IAC)
- Sec. ~~21~~ 12.4 Water Capital Improvement Charge
- Sec. ~~21~~ 12.5 Billing Periods
- ~~21~~ 12.5.1 Unclaimed Funds
- Sec. ~~21~~ 12.6 Meter Locks and Restrictors
- Sec. ~~21~~ 12.7 Meter Not Registering
- Sec. ~~21~~ 12.8 Water Rates or Service Charges Lien on Property
- ~~21~~ 12.8.1 Theft of Water
- Sec. ~~21~~ 12.9 Volumetric Wastewater Charges
- Sec. ~~21~~ 12.10 Monthly Fixed Wastewater Charge
- ~~21~~ 12.10.1 Wastewater Capital Improvement Charge
- Customer Classes (Appendix A)

**ARTICLE ~~22~~ 13 EASEMENTS (Renumbered from previous Article 22)**

- Sec. ~~22~~ 13.1 Requirement for Easements
- Sec. ~~22~~ 13.2 Acceptance of Easements
- Sec. ~~22~~ 13.3 Granting of Easements

**ARTICLE ~~23~~ 14 CONSTRUCTION, REGULATIONS GOVERNING (Renumbered from previous Article 23)**

- Sec. ~~23~~ 14.1 Water Line Extensions and Replacements, by the District
- Sec. ~~23~~ 14.2 Water Line Extensions, Privately Financed
- Sec. ~~23~~ 14.3 Water & Sewer Line Extensions, Repayment Agreements
- ~~23~~ 14.3.1 Administrative Costs
- Sec. ~~23~~ 14.4 Pipeline Extensions, Sewer
- ~~23~~ 14.4.1 Process
- ~~23~~ 14.4.2 Agreement
- ~~23~~ 14.4.3 Fees
- Sec. ~~23~~ 14.5 Construction Ownership and Maintenance of Sewer Lateral Pipelines
- Sec. ~~23~~ 14.6 Temporary Sewer Service Connections

**ARTICLE ~~24~~ 15 STANDBY OR AVAILABILITY CHARGES (Renumbered from previous Article 24)**

- Sec. ~~24~~ 15.1 Definition
- Sec. ~~24~~ 15.2 Water Availability Charges

\* As of February 2021, the Board of Directors adopted Resolution 5006, and the Table of Contents was renumbered to remove unused articles and make existing articles sequential.

	<a href="#">24 15.2.1</a>	Fallbrook Service Area
	<a href="#">24 15.2.2</a>	DeLuz Improvement District
Sec. <a href="#">24 15.3</a>		Exemptions
Sec. <a href="#">24 15.4</a>		Collection of Standby/Availability Charges
Sec. <a href="#">24 15.5</a>		Deferral of Charge
	<a href="#">24 15.5.1</a>	Application
	<a href="#">24 15.5.2</a>	Appeal to Board of Directors
	<a href="#">24 15.5.3</a>	Deferred Charges on Restricted Parcels
	<a href="#">24 15.5.4</a>	Deferred Charges on Partial Parcels
	<a href="#">24 15.5.5</a>	Surcharge
	<a href="#">24 15.5.6</a>	Refunds
	<a href="#">24 15.5.7</a>	Enforcement Procedures
Sec. <a href="#">24 15.6</a>		Certified Copies
Sec. <a href="#">24 15.7</a>		Correction of Errors

**ARTICLE [25 16](#) TAX LEVY [\(Renumbered from previous Article 25\)](#)**

Sec. <a href="#">25 16.1</a>	Definitions
Sec. <a href="#">25 16.2</a>	General Bonded Indebtedness
Sec. <a href="#">25 16.3</a>	Money to be Raised by Taxation
Sec. <a href="#">25 16.4</a>	Full Valuation of Taxable Property
Sec. <a href="#">25 16.5</a>	Certified Copies

**ARTICLE [26 17](#) WATER SHORTAGE RESPONSE PLAN [\(Renumbered from previous Article 26\)](#)**

Sec. <a href="#">26 17.1</a>	Declaration of Policy
	<a href="#">26 17.1.1</a> PSAWR Reduction Program
	<a href="#">26 17.1.2</a> PSAWR Reduction Compliance
Sec. <a href="#">26 17.2</a>	Findings
Sec. <a href="#">26 17.3</a>	Application
Sec. <a href="#">26 17.4</a>	Determination and Declaration by General Manager of Water Supply Conditions
Sec. <a href="#">26 17.5</a>	Implementation of Emergency Water Management Program
Sec. <a href="#">26 17.6</a>	Duration of Declaration
Sec. <a href="#">26 17.7</a>	Mandatory and Discretionary Use of Recycled Water
Sec. <a href="#">26 17.8</a>	Water Conservation Stages
	<a href="#">26 17.8.1</a> Normal Conditions
	<a href="#">26 17.8.2</a> Water Shortage Response Level 1 – Water Shortage Watch Condition
	<a href="#">26 17.8.3</a> Water Shortage Response Level 2 – Water Shortage Alert Condition
	<a href="#">26 17.8.4</a> Water Shortage Response Level 3 – Water Shortage Critical Condition
	<a href="#">26 17.8.5</a> Water Shortage Response Level 4 – Water Shortage Emergency Condition
	<a href="#">26 17.8.6</a> Drought Rates
Sec. <a href="#">26 17.9</a>	Implementation of Conservation Levels
Sec. <a href="#">26 17.10</a>	Variances
	<a href="#">26 17.10.1</a> Application
	<a href="#">26 17.10.2</a> Supporting Documentation
	<a href="#">26 17.10.3</a> Required Findings for Variance

[\\* As of February 2021, the Board of Directors adopted Resolution 5006, and the Table of Contents was renumbered to remove unused articles and make existing articles sequential.](#)

- ~~26~~ 17.10.4 Approval Authority
- ~~26~~ 17.10.5 Appeals to FPUD Board of Directors

**ARTICLE ~~27~~ 18 INVESTMENT POLICY (Renumbered from previous Article 27)**

- Sec. ~~27~~ 18.1 General
  - ~~27~~ 18.1.1 Delegation of Authority
  - ~~27~~ 18.1.2 Investment Objectives
  - ~~27~~ 18.1.3 Prudent Investor Standard
- Sec. ~~27~~ 18.2 Treasurer’s Annual Statement of Investment Policy
  - ~~27~~ 18.2.1 Security of Principal Policy
  - ~~27~~ 18.2.2 Liquidity Policy
  - ~~27~~ 18.2.3 Return Policy
  - ~~27~~ 18.2.4 Maturity Policy
  - ~~27~~ 18.2.5 Prohibited Securities
- Sec. ~~27~~ 18.3 Internal Controls
- Sec. ~~27~~ 18.4 Permissible Investments
  - ~~27~~ 18.4.1 Government Obligations
  - ~~27~~ 18.4.2 Banker’s Acceptance
  - ~~27~~ 18.4.3 Commercial Paper
  - ~~27~~ 18.4.4 Medium-Term Notes
  - ~~27~~ 18.4.5 Repurchase Agreements
  - ~~27~~ 18.4.6 Negotiable Certificates of Deposit
  - ~~27~~ 18.4.7 State Local Agency Investment Fund (LAIF)
  - ~~27~~ 18.4.8 San Diego County Treasurer’s Fund
  - ~~27~~ 18.4.9 Passbook and Money Market Savings Accounts
  - ~~27~~ 18.4.10 State Obligations/State of California and Other States
  - ~~27~~ 18.4.11 California Local Agency Obligations
  - ~~27~~ 18.4.12 Joint Powers Authority Pool
  - ~~27~~ 18.4.13 Money Market Mutual Funds
  - ~~27~~ 18.4.14 Mortgage Pass-Through Securities and Asset-Backed Securities
  - ~~27~~ 18.4.15 Supranationals
- Sec. ~~27~~ 18.5 Maturity/Limit of Investments
- Sec. ~~27~~ 18.6 Reporting Requirements
  - State and Federal Credit Union Deposit Restrictions
  - Acknowledgement (Attachment A)

**ARTICLE ~~28~~ 19 RECYCLED WATER PROGRAM (Renumbered from previous Article 28)**

- Sec. ~~28~~ 19.1 Declaration of Policy
- Sec. ~~28~~ 19.2 Statutory Requirements
- Sec. ~~28~~ 19.3 Approved Use
- Sec. ~~28~~ 19.4 Definitions
- Sec. ~~28~~ 19.5 Administration
- Sec. ~~28~~ 19.6 Suspension or Termination of User Service
  - ~~28~~ 19.6.1 Reasons
  - ~~28~~ 19.6.2 Procedure
  - ~~28~~ 19.6.3 Appeals of the Suspension or Termination Notice
  - ~~28~~ 19.6.4 Prohibited Connections
- Sec. ~~28~~ 19.7 Implementation
  - ~~28~~ 19.7.1 Designation of Users
  - ~~28~~ 19.7.2 Appeal

\* As of February 2021, the Board of Directors adopted Resolution 5006, and the Table of Contents was renumbered to remove unused articles and make existing articles sequential.

<del>28</del> <u>19</u> .7.3	Design and Construction of On-Site Facilities
<del>28</del> <u>19</u> .7.4	Recycled Water Supervisor
<del>28</del> <u>19</u> .7.5	Conversion of Existing Facilities
<del>28</del> <u>19</u> .7.6	User Agreement Form
Sec. <del>28</del> <u>19</u> .8	Water Meter Requirement
Sec. <del>28</del> <u>19</u> .9	Public Safety Requirements
<del>28</del> <u>19</u> .9.1	General Requirements
<del>28</del> <u>19</u> .9.2	Backflow Protection at the Service Meter
Sec. <del>28</del> <u>19</u> .10	Truck Load Delivery of Recycled Water
Sec. <del>28</del> <u>19</u> .11	Miscellaneous
Sec. <del>28</del> <u>19</u> .12	Non-Liability

**ARTICLE ~~29~~ 20      EMERGENCY ACTION PLAN (EAP) (Renumbered from previous Article 29)**

**~~ARTICLE 30~~      ~~PROHIBITED USE OF DISTRICT FACILITIES (Repealed in its Entirety Aug 24, 2020)~~**

**~~ARTICLE 31~~      ~~FATS, OILS & GREASE PROGRAM (FOG) (Repealed in its Entirety Aug. 24, 2020)~~**

**ARTICLE ~~32~~ 21      RECORDS RETENTION AND DESTRUCTION POLICY (Renumbered from previous Article 32)**

Sec. <del>32</del> <u>21</u> .1	Purpose
Sec. <del>32</del> <u>21</u> .2	Authorization to Implement Policy
Sec. <del>32</del> <u>21</u> .3	Government Code (Chapter 7) Sections Providing for the Destruction of Records of Special Districts
Sec. <del>32</del> <u>21</u> .4	State Controller’s Guidelines
Sec. <del>32</del> <u>21</u> .5	General Provisions
<del>32</del> <u>21</u> .5.1	Public Records Policy
<del>32</del> <u>21</u> .5.2	Definitions
<del>32</del> <u>21</u> .5.3	Records Exempt from Disclosure
<del>32</del> <u>21</u> .5.4	Government Code 6255
<del>32</del> <u>21</u> .5.5	Right of Privacy
<del>32</del> <u>21</u> .5.6	Procedures for Access to Public Records
<del>32</del> <u>21</u> .5.7	Records Retention and Destruction Policy
Sec. <del>32</del> <u>21</u> .6	California Public Records Act (Exhibit A)
Sec. <del>32</del> <u>21</u> .7	Records Retention Schedule (Exhibit B)

**~~ARTICLE 33~~      ~~ENVIRONMENTAL REVIEW (Repealed in its Entirety Oct. 24, 2016)~~**

**ARTICLE ~~33~~ 22      SOCIAL MEDIA POLICY AND PROCEDURE (Renumbered from previous Article 33)**

Sec. <del>33</del> <u>22</u> .1	General Purpose
Sec. <del>33</del> <u>22</u> .2	Definitions (Secs. 33.2.1—33.2.3)
Sec. <del>33</del> <u>22</u> .3	General Policy (Secs. 33.3.1—33.3.16)
Sec. <del>33</del> <u>22</u> .4	Content Guidelines (Secs. 33.4.1—33.4.12)

\* As of February 2021, the Board of Directors adopted Resolution 5006, and the Table of Contents was renumbered to remove unused articles and make existing articles sequential.

**Attachment B**  
**Existing Administrative Code Articles 14-29, 32**  
**and 33**

**Article 14.5. District Procurement Procedures.**

**Sec. 14.5.1 Authority.**

California Public Contract Code Sections 20200-20207.7, as well as other provisions in the California Public Contract Code, certain miscellaneous statutes found in the Public Utility District Act (Public Utilities Code Section 15501 et seq.), and the California Government Code, govern procurement (purchasing and contracting) by the District of the following:

- Articles such as goods, materials, supplies, equipment, capital assets, and advertising
- Works of construction, alteration, and non-professional services (including repair and maintenance)
- Professional services

The District has elected to become subject to the provisions of the Uniform Public Construction Cost Accounting Act (the "Act"), Public Contract Code Section 22000 et seq., which provides alternative procedures for the bidding and awarding of public contracts. As provided in Public Contract Code Section 22003, these procedures may also be utilized for maintenance work and other work that does not fall within the definition of "public project." Accordingly, it is the District's intent to utilize these procedures for "public projects" and all other purchases otherwise subject to Public Contract Code Sections 20200-20207.7.

The provisions of this Article 14.5 shall not apply to the acquisition of land by the District.

**Sec. 14.5.2 General.**

The ongoing operation of the District requires the procurement of various items, construction and services. Since it is necessary to procure these items, construction and services on a regular basis to carry on the day-to-day operations of the District, and since the Board of Directors reviews and approves all procurements through the budgeting process, or otherwise approves procurements by separate action from time to time, the following formal procurement policies and procedures are provided for implementation by District staff. These formal procedures are intended to implement the above-listed requirements of the California Public Contract Code, California Government Code, and California Public Utilities Code, which are mandatory for Public Utility Districts located within the State of California. State law forbids any director or other officer of the District from being interested, directly or indirectly, in any contract awarded or to be awarded by the Board, or in the profits to be derived from it.



Sec. 14.5.3 Procurement Philosophy.

Purchases of goods, materials, supplies, equipment, and capital assets shall be made from time to time, in the most economical quantity, in order to provide the District with maximum benefit for minimum expenditures. Quality and reliability of products are also important factors which may, on a case-by-case basis, cause rejection of an inferior product that does not meet specified requirements. It is also essential that purchases of all goods, materials, supplies, equipment, and capital assets be done by the District in a fair and open manner that promotes public confidence in the District and reinforces the public perception of fairness and equal opportunity for all competing vendors offering their products or services to the District. Contracts for works of construction and all services shall be made from time to time, after complying with applicable legal requirements and these procurement policies and procedures. To the extent permitted by law, and subject to the limitations established in Section 14.5.10, purchases should be made from vendors located within the boundaries of the District.

Sec. 14.5.4 Definitions.

- a. Articles. Goods, materials, supplies, equipment, capital assets, and advertising required to carry on the day-to-day operations of the District, including without limitation, office supplies, computer hardware and software, communications equipment, equipment, materials and supplies for distribution and treatment, including meters, meter parts, and pipeline materials.
- b. Commission. The California Uniform Construction Cost Accounting Commission.
- c. Designee. The General Manager may authorize the following persons as his designee in those areas in which they exercise budgeting control:
  - (1) Assistant General Manager/Chief Financial Officer – (Articles related to office equipment and supplies, all computer hardware and software, communication equipment, and contract services).
  - (2) Operations Manager – (Articles used for distribution and treatment and SCADA).
  - (3) Field Services Manager – (Construction and field equipment and materials, contract change orders).
  - (4) Chief Plant Operator – (Articles used for treatment).
  - (5) Senior Engineer – (Contract services, contract change orders).
  - (6) Senior Accountant – (Contract services, articles related to office equipment and supplies).

- (7) Field Supervisors – (Articles such as field equipment and materials).
- (8) Warehouse Supervisor – (Warehouse related articles).
- d. Maintenance. As defined in Public Contract Code § 22002, Maintenance includes all of the following: (1) routine, recurring, and usual work for the preservation or protection of any publicly owned or publicly operated facility for its intended purposes (2) minor repainting (3) resurfacing of streets and highways at less than one inch (4) landscape maintenance, including mowing, watering, trimming, pruning, planting, replacement of plants, and servicing of irrigation and sprinkler systems (5) work performed to keep, operate, and maintain publicly owned water, power, or waste disposal systems, including, but not limited to, dams, reservoirs, powerplants, and electrical transmission lines of 230,000 volts and higher.
- e. Open Purchase Order. A purchase order for Articles which is effective for a specified period of time, not more than annually, and within the same budget year, i.e., office supplies and auto parts.
- f. Professional Services. Professional services, such as services involving provision of a report, study, plan, design, specification, document, program, advice, recommendation, analysis, review, inspection, investigation, audit, brokering or representation of the District before or in dealings with another party, or any other services which require a special skill or expertise of a professional, scientific or technical nature. Professional Services include architectural, landscape architectural, engineering, environmental, land surveying, construction project management services. Professional Services also include legal, financial, accounting, and planning services.
- g. Public Project. Defined in Cal. Public Contract Code § 22002, means any of the following: (1) Construction, reconstruction, erection, alteration, renovation, improvement, demolition, and repair work involving any publicly owned, leased, or operated facility and (2) Painting or repainting of any publicly owned, leased, or operated facility.

Sec. 14.5.5 Procedures for the Purchase of Public Projects, Maintenance, and Articles

- a. Purchase Procedures for Public Projects, Maintenance, and Articles in the Amount of \$45,000 or Less (“Small Purchase Procedures”).

The General Manager or Designee may make purchases of Public Projects, Maintenance, and Articles in an amount of \$45,000 or less, in accordance with the following Small Purchase Procedures, which the Board has imposed for such purchases, in the interests of sound business judgment.

- (1) Purchases of \$10,000 or more shall be made after obtaining three (3) written quotations. Purchases under \$10,000 shall be purchased in the most prudent and economical manner possible, but do not require multiple competitive quotations.
- (2) The requirement for three (3) quotations is not required in those cases where the Board has approved the purchase as a “standardized item” such as meters, or for Open Purchase Orders as provided below.
- (3) Small Purchase Procedures specific to Articles. All purchases shall be made by purchase order after a properly authorized Purchase Order Requisition (POR) has been completed, signed and forwarded in the required manner. The only exceptions to this requirement are purchases made under a pre-existing Open Purchase Order, purchase of small routine items from suppliers with open purchase order or accounts, or purchases made during emergency. The purchase order must indicate the name of the suggested vendor and an exact description and price of each Article. Shipping charges, if any, and applicable taxes must also be included in the total price. The purchase order shall be reviewed and signed by the General Manager or Designee.

Open Purchase Orders shall generally be utilized for the purchase of repetitive need, low-valued Articles or for the purchase of Articles (such as automotive supplies) which must be available on short notice. Open Purchase Orders shall not be utilized as a substitute for the normal requisition and purchase order process described in this section. Open Purchase Orders may be written for a single class of consumable Articles i.e., office supplies, without listing specific, exact descriptions of each Article, but not to exceed the authority listed above and cannot span a period of time which includes more than one fiscal year.

- (4) Small Purchase Procedures specific to Public Projects and Maintenance. All purchases shall be made by written contract. Any such contracts shall be awarded on the basis of price and such other criteria established by the General Manager or Designee, as may be in the best interest of the District, in light of the type of work involved. Contracts for Public Projects shall require the successful bidder to execute a bond, in a form approved by the Board, for the faithful performance of the contract. Additionally if the contract exceeds \$25,000 and involves erection, construction, alteration, repair or improvement of any public structure, building, road or other public improvement of any kind, the successful bidder shall execute a payment bond, as required by the provisions of the California Civil Code.
- (5) Petty cash. Occasionally purchases of minor items may be required. Payments for such items may be authorized from petty cash funds by the General Manager or Designee. In no case will approval exceed \$50.00.

- (6) Quote information shall be retained until completion of the annual audit for the fiscal year in which purchased, or as otherwise established in the District's Records Retention Schedule.
  - (7) Nothing in these Small Purchase Procedures shall prevent the General Manager, or Designee, from obtaining multiple quotations or from implementing the Informal Bid Procedures or Formal Bid Procedures if it is in the best economic interests of the District to do so. This judgment shall be made in the sole discretion of the General Manager or Designee.
  - (8) Nothing in these Small Purchase Procedures shall prohibit the District from doing or causing to be done directly by the District, and without any contract, any or all work necessary or proper in or about the making of all current and ordinary repairs or in or about current and ordinary upkeep or maintenance.
  - (8) Under no circumstances shall purchases be split or separated into multiple purchases in order to avoid the Small Purchase Procedures, Informal Bid Procedures and/or Formal Bid Procedures set forth herein
- b. Purchase Procedures for Public Projects, Maintenance, and Articles in Excess of \$45,000 and \$175,000 or Less ("Informal Bid Procedures").

In accordance with Public Contract Code Section 22034, the District adopts the following Informal Bid Procedures, applicable to purchases of Public Projects, Maintenance, and Articles in excess of \$45,000 and \$175,000 or less. Contract award shall be made by the Board.

- (1) The District shall maintain a list of qualified contractors, identified according to categories of work. Minimum criteria for development and maintenance of the contractors list shall be as required by the Commission.
- (2) All contractors on the list for the category of work being bid or all construction trade journals pursuant to in Public Contract Code Section 22036, or both all contractors on the list for the category of work being bid and all construction trade journals pursuant to in Public Contract Code Section 22036, shall be mailed, faxed or emailed, a notice inviting informal bids unless the product or service is proprietary.
- (3) All delivery of notices inviting informal bids to contractors and construction trade journals shall be completed not less than 10 calendar days before bids are due. The notice inviting informal bids may also be published in in a newspaper of general circulation.

- (4) The notice inviting informal bids shall describe the project in general terms and how to obtain more detailed information about the project, and state the time and place for the submission of bids.
- (5) If all bids received are in excess of \$175,000, the Board may, by adoption of a resolution by a four-fifths (4/5) vote, award the contract, at one \$187,500 or less, to the lowest responsible bidder, if it determines the cost estimate of the District is reasonable.
- (6) If awarded, a contract will be awarded to the lowest responsible bidder, consistent with the quality and delivery requirements.
- (7) All contracts for Public Projects shall require the successful bidder to execute a bond, in a form approved by the Board, for the faithful performance of the contract. Additionally if the contract involves erection, construction, alteration, repair or improvement of any public structure, building, road or other public improvement of any kind, the successful bidder shall execute a payment bond, as required by the provisions of the California Civil Code.
- (8) The Board shall have the right to reject all or any of the bids received.

c. Purchase Procedures for Public Projects, Maintenance, and Articles in Excess of \$175,000 (“Formal Bid Procedures”).

Purchases of Public Projects, Maintenance, and Articles in an amount exceeding \$175,000 shall be procured pursuant to the following Formal Bid Procedures. Contract award shall be made by the Board. Additionally, all plans and specifications for Public Projects shall be adopted by the Board or General Manager/ Designee.

- (1) In accordance with Public Contract Code Section 22037, a notice inviting formal bids shall be published in a newspaper of general circulation, printed and published, at least 14 calendar days before the date of opening the bids, in the jurisdiction of the District and any such other newspaper publications deemed appropriate by the General Manager or Designee. Notice inviting formal bids shall state the time and place for the receiving and opening of sealed bids and distinctly describe the project.

If applicable, the notice inviting formal bids shall also be sent electronically, if available, by either facsimile or electronic mail and mailed to all construction trade journals. The notice shall be sent at least 15 calendar days before the date of opening the bids.

- (2) All bids for shall be presented under sealed cover. If awarded, a contract will be awarded to the responsible bidder who submits the lowest responsive bid.
- (3) All bids for Public Projects shall be accompanied by one of the following forms of bidder's security:
  - i. Cash
  - ii. A cashier's check made payable to the District
  - iii. A certified check made payable to the District
  - iv. A bidder's bond executed by an admitted surety insurer made payable to the District in the form provided by the District

Upon an award to the lowest bidder, the security of an unsuccessful bidder shall be returned in a reasonable period of time, but in no event shall that security be held by the District beyond 60 days from the time the award is made.

- (4) All contracts for Public Projects shall require the successful bidder to execute a bond, in a form approved by the Board, for the faithful performance of the contract. Additionally if the contract involves erection, construction, alteration, repair or improvement of any public structure, building, road or other public improvement of any kind, the successful bidder shall execute a payment bond, as required by the provisions of the California Civil Code.
  - (5) The Board shall have the right to reject all or any of the bids received.
- d. Nothing in this Section shall preclude the District from utilizing the design-build project delivery method where authorized by and in accordance with the provisions and requirements set forth in California Public Contract Code Section 22160 et seq., as it may be amended from time to time.

Sec. ~~14~~ 5.6 Procedures for Procurement of Professional Services.

- a. Pursuant to California Government Code Section 4526 et seq., the District shall secure professional services on the basis of demonstrated competence and on the professional qualifications necessary for the satisfactory performance of the services required. When specific technical expertise or experience is required, the District may negotiate the scope and fee for these services with an individual firm with this specific expertise.
- b. The District may, for procurement of architectural, landscape architectural, engineering, environmental, land surveying, and construction management services, utilize the Qualification-Based Selection procedures adopted by the

Architects and Engineers Conference Committee of California, as deemed appropriate by the General Manager or Designee.

- c. If the value of the services are estimated to be \$45,000 or more, the District shall issue a formal Request for Proposals for the services. Additionally, if deemed in the best interests of the District as determined by the General Manager or Designee, the District may first issue a Request for Qualifications to solicit firms with the necessary qualifications for the services.
- d. If the value of the services are estimated to be less than \$45,000, where practical, three proposals shall be obtained unless the General Manager or Designee deems otherwise appropriate.
- e. Award of Professional Services Contracts may be made by the General Manager for contracts in the amount of \$45,000 or less. Contracts in excess of \$45,000 shall be awarded by the Board.
- f. The contract amendment procedures outlined in this Article apply to Professional Services Contracts.

Sec. ~~14~~ 5.7 Prequalification.

The District may prequalify contractors, pursuant to the provisions and requirements of California Public Contract Code Section 20101, as determined appropriate in the reasonable discretion of the General Manager or District Engineer. Prequalification shall be through a uniform system of rating bidders on the basis of completed questionnaires and financial statements in a form specified by the Board. The District may accordingly limit bids or proposals it receives to those contractors who are prequalified.

Sec. ~~14~~ 5.8 Emergencies.

California Public Contract Code Section 22050 authorizes special contracting procedures in cases of “emergency.” An “emergency” for purposes of Section 22050 is defined as a sudden, unexpected occurrence that poses a clear and imminent danger, requiring immediate action to prevent or mitigate the loss or impairment of life, health, property, or essential public services.

In the case of an emergency, as defined herein, the General Manager or Designee, may repair or replace a public facility, take any directly related and immediate action required by the emergency, and procure the necessary equipment, services, and supplies for those purposes, without giving notice for bids to let contracts. The General Manager, or Designee, must report to the Board at its next meeting required pursuant to this Section ~~14~~ 5.8, the reasons justifying why the emergency will not permit a delay

resulting from a competitive solicitation for bids and why the action is necessary to respond to the emergency.

If the General Manager or Designee, orders any action specified herein, the Board shall initially review the emergency action not later than seven days after the action, or at its next regularly scheduled meeting if that meeting will occur not later than 14 days after the action, and at least at every regularly scheduled meeting thereafter until the action is terminated, to determine, by a four-fifths vote, that there is a need to continue the action, unless the General Manager or Designee, has terminated that action prior to the Board reviewing the emergency action and making a determination. When the Board reviews the emergency action, it shall terminate the action at the earliest possible date that conditions warrant so that the remainder of the emergency action may be completed by giving notice for bids to let contracts.

Sec. 14.5.9 Exceptions to Procurement Requirements.

a. Sole Source Exception.

Notwithstanding any provision in this Article 14.5, the procurement requirements set out in this Article 14.5 shall not apply to the procurement of Articles, Professional Services, Public Projects, or Maintenance that can only be obtained from one supplier or contractor and for which obtaining quotes or bids is therefore impossible or not in the public interest, such that no competitive advantage can be gained by soliciting quotes or bids. Sole source contracts or agreements up to \$45,000 may be procured by the General Manager or Designee. The Board must approve any source contracts or agreements of \$45,000 or more.

b. Purchases when Price Controlled by an Official Rate-Making Body.

Whether approved by the General Manager or Designee, or the Board, the District is authorized to procure services or Articles without quotation or bid if the price is controlled by an official rate-making body such as is the case with wholesale water from SDCWA, electricity, gas and telephone, and the services are provided for in the operating budget.

Sec. 14.5.10 Local Procurements.

- a. It is the District's policy to encourage local businesses to provide goods and services to the District in order to maintain a healthy local economy, to increase local competition, and to lower core costs of goods and services. Local preference for the procurement of eligible contracts may be allowed, so long as it is not otherwise prohibited by funding sources, by providing a 5% local preference where the purchase or contracts with a respective local vendor or business during any fiscal year do not exceed \$45,000. In order to qualify for this local preference, a vendor or business must either (a) be a District rate payer in good standing for the



past six months, or (b) receive District utility services at its business location for the past six months, paid by a third party.

- b. Eligible procurements include those contracts which are not otherwise subject to competitive bidding, including contracts for the following:
  - (1) Purchases of Public Projects, Maintenance, and Articles in the amount of \$45,000 or less, pursuant to Section 14.5.5(a).

Sec. 14.5.11 Sale of Surplus Property/Equipment and Scrap Metal.

- a. Surplus Property/Equipment. When it has been determined by the General Manager that equipment is no longer appropriate because of capability, size, age, etc., to fulfill the District's mission or if a particular piece of equipment is more costly to maintain than to replace, the item will be disposed of through the next scheduled San Diego County auction. Should property become surplus through obsolescence or through a change in operating methodology, the excess property will be disposed of, as determined by District staff, as follows:
  - (1) To other public agencies on a bid basis;
  - (2) San Diego County Auction, or
  - (3) Internet-based inline auction services.
- b. Scrap Metal. The scrap metal which accumulates through the replacing of damaged and/or unserviceable items in the course of District operations, shall be sold as scrap to local scrap dealers at prevailing rates. Sales receipts shall be miscellaneous revenues of the District.

Sec. 14.5.12 Use of District Credit Card.

- a. There are certain transactions that are more efficient using a credit card transaction. Examples include small purchases that are lower cost on-line, travel arrangements, registration for training and other similar services.
- b. The credit card shall never be used to circumvent established competitive purchasing procedures. The credit card is prohibited from being used to purchase items for personal use under all circumstances. Personal use of the credit card will result in disciplinary action.
- c. Authorized cardholders and credit card use shall be per the District Credit Card Users Guide as approved by the General Manager.

Sec. 14.5.13 Contract Amendment Procedures.

As delegated by the Board of Directors of the District pursuant to the provisions of the Public Utility District Act, the General Manager is authorized to issue amendments to contracts as follows:

- a. A purchase order or contract may be amended by the issuance of a change order or amendment, provided the change which is the subject of the change order or amendment is reasonably related to the scope of the original contract. The General Manager may issue a change order or amendment which results in a total contract price of \$45,000.00 or less. The General Manager may request approval authority from the Board to issue contract amendments for up to 10% of the total contract value for specific projects with an initial contract value of greater than \$45,000.
- b. When the cumulative sum of amendments to a contract would exceed the limits in (a) above, a report of such amendments will be presented to the Board at its next meeting. Upon acceptance of the amendments by the Board, the General Manager shall have additional authorization to issue amendments as if the original contract amount were the total of the original amount and all accepted amendments.

**ARTICLE 14 (Renumbered  
as Article 5 by Resolution  
5006)**

Sec. 14.7 - Rev. 4/95  
Sec. 14.10 - Rev. 3/96  
Sec. 14.5(a), 14.6(a) & (d),  
14.7(d) - Rev. 6/99  
Sec. 14.11 - Added 10/05  
Sec. 14.4e(2), 14.10(c) &  
14.12(g) - Rev. 6/06  
Sec. 14.5(g) - Rev. 8/08  
Sec. 14.4(e), Rev 01/09  
Secs.14.4(e)1,3,4,5,(f);  
14.5(a)(d); 14.6(c)(d); 14.7(d);  
14.9(b); 14.11(c) - Rev. 2/10  
Add Sec. 14.12 - Rev. 2/11  
Secs. 14.4; 14.9 - Rev. 1/13  
Secs. 14.4; 14.13 - Rev. 7/13  
Sec. 14.4 - Rev. 5/15  
Sec. 14.4(f), 14.9(c) - Rev. 1/16  
All Secs. Repealed and Replaced  
- Rev. 6/17  
Sec. 14.4 - Rev. 5/19

## Article 15.6. Budget and Fund Management

### Sec. 15.6.1 District's Annual Budget.

Preparation of the District Budget is directed by the Assistant General Manager/CFO. Working with the Fiscal Policy and Insurance Committee the General Managers develops annual financial goals and objectives for the budget in February. A first preliminary Budget is presented to the Committee/Board of Directors and public in April and a second preliminary Budget in May. The final Budget is presented in June for adoption, along with a resolution adopting a tax rate for Bonded Indebtedness.

The budgeting process is intended to create a transparent process that enables the Board of Directors to estimate the Districts revenues and expenses including employee compensation arising from negotiations and changes in other costs of operations.

#### 15.6.1.1 Annual Budget Resolution.

The Board shall approve an annual budget resolution that establishes the total appropriation for the fiscal year based on the following budget categories:

1. Administration, operations, and maintenance
2. Water purchases and contingencies
3. Capital improvements and equipment
4. Revenue Bonds, State Revolving Fund, interest, and principal
5. Established annual Liquidity Fund level

In addition, the budget resolution shall identify any anticipated net withdrawal of District reserves for the Fiscal Year. Any unanticipated net withdrawal of District reserves shall be a separate board action. Any withdrawal of funds from long-term investments, as shown in the District's Treasurer's Report, shall require prior Board approval.

Any spending above the established appropriations or additional withdrawal of reserves shall require Board approval. As part of the annual budget process, the Board will review and approve the District's liquidity fund level.

### Sec. 15.6.2 Treasurer's Fund.

The Treasurer's Fund is established primarily to account for all District cash and investments and also to record detailed accounting for fringe benefits. Revenues are obtained from a budgeted mark-up on District labor. Revenue and Expense accounts in this fund are closed to the Utility fund annually.

### Sec. 15.6.3 General Fund.

The General Fund shall consist of accounts for property tax revenues and appropriations to other funds as determined by the Board.

### Sec. 15.6.4 Utility Funds.

The Utility Funds consists of three separate funds reflecting the operating departments of Water, Wastewater and Recycled Water. The funds reflect the revenues from water sales, monthly service charges and other recurring fees and all expenses, including Operating and Maintenance (O&M) and General & Administrative (G&A).

Sec. ~~15~~ 6.5 Capital Funds.

The Capital Funds consists of all Property, Plant and Equipment and the expenditures as well as revenues from Capital Improvement Charges that are dedicated/restricted to capital expenditures. All use of revenues in the Capital Funds is restricted to capital investments, which includes capital assets as defined by the District's accounting policy and debt service. Sources of funding and expenditures for capital assets are maintained in three separate funds:

Water – all capital assets associated with the water treatment and distribution system; all administrative buildings and equipment; and all construction equipment and vehicles.

Wastewater – all capital assets associated with treatment facilities and the wastewater collection system.

Recycled Water – all capital assets associated with the recycled water facilities and the recycled water distribution system.

Sec. ~~15~~ 6.6 Equipment Fund.

The Equipment Fund consists of all expenses for field equipment operations, maintenance, repair and replacement. Revenues are obtained from a budgeted mark-up on District labor. Revenue and expenses are closed to the Utility fund annually.

Sec. ~~15~~ 6.7 Debt Service Funds.

Debt Service funds shall be established to account for General Obligation Bonds, Certificates of Participation, or other indebtedness which the District may incur for construction, completion, or acquisition of works, for the treatment, storage and distribution of water and water rights, including dams, reservoirs, storage tanks, treatment facilities, pipes, pumping equipment, and all necessary equipment and property therefor. The funds shall record annual transactions showing source of revenue, and both interest and principal payments.

Sec. ~~15~~ 6.8 Appropriated Fund Balances.

Appropriated Fund Balances shall be established to provide adequate funding to meet the District's short term and long term plans and commitments; to minimize adverse annual and multi-year budgetary impacts from unanticipated expenditures; and to preserve the financial stability of the District against present and future uncertainties in an ever-changing environment. The following Appropriated Fund Balances will be established and maintained.

~~15~~ 6.8.1 Utility Funds Appropriated Fund Balances.

1. Water.

- a) Working Capital. To be established and maintained at a level of three months operating and maintenance expenses including water purchases.

- b) Santa Margarita Debt Payment Fund. To prevent “spikes” and mid-year changes in rates because of net revenue shortfalls due to weather conditions, state or federal legislation or other future uncertainties. The target level is set equal to 2-years of debt service payments on the Santa Margarita Conjunctive Use Project financing.
- 2. Wastewater.
    - a) Working Capital. To be established and maintained at a level of three months operating and maintenance expenses.
    - b) Rate Stabilization Fund. To promote smooth and predictable rates and charges a Rate Stabilization Fund is established with a target of level equal to 10% of annual revenues.
  - 3. Recycled Water.
    - a) Working Capital. To be established at three months operating and maintenance expenses.

#### 15 6.8.2 Utility Capital Funds Appropriated Fund Balances.

- 1. Water Capital Fund.

The primary source of funds are the Water and Pumping Capital Improvement charges, annexation fees, connection fees and meter fees. Target fund balance is set to the equivalent of 3-year average expenditures on recurring capital projects (*i.e.* pipeline renewal/replacement).

  - a) Funds related to the 1958 Annexation and the DeLuz Service Area bond proceeds are tracked separately in the fund.
- 2. Wastewater Capital Fund.

The primary source of funds are Wastewater Capital Improvement Charges, connection fees and meter fees. Target fund balance is set to the equivalent of 3-year average expenditures on recurring capital projects (*i.e.* pipeline renewal/replacement).
- 3. Recycled Water Capital Fund.

Target fund balance is set to the equivalent of 3-year average expenditures on recurring capital projects (*i.e.* pipeline renewal/replacement).

#### 15 6.8.3 Debt Service Funds.

Each borrowing activity is maintained within a separate Debt Service fund. Some indentures require the establishment of a reserve fund and the District must comply with any creditor imposed requirements. Since sources of funding to repay each debt instrument varies, the possibility of that inflow being interrupted is

likely/possible with different issues in differing circumstances. Because of the possibility of this interruption, each Debt Service Fund should establish an Appropriated Fund Balance equal to the next year's total debt service (principal and interest).

Sec. ~~15~~ 6.9 Petty Cash.

The responsibility for and the accountability for the petty cash fund is assigned to the Assistant General Manager/CFO and/or the Accountant. The fund at all times will total \$400.00 in cash and disbursement receipts. When an employee requires reimbursement, not-to-exceed \$50.00, for an out-of-pocket District expense, a petty cash voucher is filled out and the receipts for purchases attached.

Reimbursement will not be made from the petty cash fund without the immediate supervisor's approval on the petty cash voucher and receipts attached thereto.

During the planned absence of either the Assistant General Manager/CFO or Accountant, the Supervising Accounting Assistant will be authorized to make petty cash reimbursements. Prior to assumption of these duties, cash in the fund will be counted and verified by both the Assistant General Manager/CFO and Accountant.

Periodic audits will be performed as required by District management or the Auditor. Checks drawn to replace the disbursement will be processed in the same manner as any other invoice paid by the District.

<b>ARTICLE</b>	<b>15</b>
<u>(Renumbered</u>	<u>as</u>
<u>Article 6</u>	<u>by</u>
<u>Resolution 5006)</u>	
Sec. 15.8 - Rev.74/97	
Sec. 15.4 & 15.5 – Rev. 4/03	
Sec. 15.8 added 4/03	
Sec. 15.1 & 15.9 – Rev. 6/06	
Sec. 15.9 – Rev. 8/08	
Sec. 15.6 – Rev. 9/09	
Sec. 15.8.1 – Rev. 12/09	
Secs. 15.1, 15.5, 15.8.1, 15.8.2, 15.8.4, 15.9 – Rev. 1/18	
Secs. 15.1.1, 15.8.1 – Rev. 2/19	
Sec. 15.1.1 – Rev. 4/19	
Sec. 15.1 – Rev. 7/19	

## Article 167-A. Insurance Claims Handling Procedures (JPIA)

### Sec. ~~167~~A.1 General.

The District is a member of the Association of California Water Agencies/Joint Powers Insurance Authority (ACWA/JPIA) and obtains its general liability and real property insurances from them. It is the policy of JPIA to see that all liability claims made against its member districts are investigated and settled expeditiously. Decisions regarding the disposition of a claim shall be based on the merits of that claim; including the legal liabilities involved, the nature and extent of damage, and the coverage afforded by and/or through JPIA. It is the policy of JPIA to pay only those claims for which member districts have legal liability.

### Sec. ~~167~~A.2 General Handling Procedures.

Before commencing a suit for money or damages against the District, the claimant must present a written claim to the District and allow it to act upon the claim. The claim must contain the name and address of claimant, P.O. box to which the person presenting a claim desires notices to be sent, date, place and circumstances of the occurrence, description of injury, damages, or losses so far as they are known, names(s) of District employee(s) causing injury or damage, the amount claimed and the basis for computation if under \$10,000 and signature of the claimant or representative.

A claim for death, personal injury, or damage to personal property must be presented within six (6) months of the accrual of the cause of action. Exceptions to the six month rule are claims for inverse condemnation, violations of federal rights, contract violations, and damage to real property.

#### ~~167~~A.2.1 Rejection of Sufficient and Timely Claims.

Only those claims with proper and sufficient contents and presented in a timely fashion may be rejected by the Board of Directors. If a claim is rejected in writing within 45 days of presentation and the rejection by the Board is in the prescribed manner, the claimant has only six (6) months in which to file suit. The claimant may also contact JPIA directly and be assigned a claims adjuster to handle their claim after the Board's rejection.

If a claim is not rejected in writing within 45 days of presentation, the claim is deemed rejected by operation of law on the 45th day. The resulting problem, however, is that the claimant then has two (2) years in which to file suit. Therefore, written claim rejections are recommended where claims are to be rejected.

#### ~~167~~A.2.2 Rejection of Insufficient and Late Claims.

An insufficient claim should not be rejected. The District must notify the claimant in writing with 20 days of presentation that the claim is insufficient and state the particulars, or the District waives the insufficiency and cannot claim insufficiency as a defense.

~~167~~A.2.3 Late Claims.

If a claim is not presented in a timely fashion, then the claimant must present an application to present a late claim within one year of accrual of cause of action, and must have a written claim attached and must set forth the reason for delay. Claims filed late, if not accompanied by an application for leave to file a late claim, should be rejected specifically because they are late. They should not be considered on their merits.

The District shall grant the application where the failure to present a claim was by excusable neglect, mistake or the like, and the District was not prejudiced, or the claimant was a minor during all of the time period, or physical or mental incapacitation or death was the cause.

The District may deny any application if it is not excused. The denial must be in writing, and must advise the claimant that he has only six (6) months to take the matter to court. The court can choose to allow the filing of the late claim on the same grounds as in acceptance of application for late claim. The denial for the application has nothing to do with the validity of the claim. It is not a rejection of the claim or its merits. It means only that the claim was not properly presented.

Sec. ~~167~~A.3 Small Claims Settlement Option.

The District has the option of settling or denying claims arising out of any occurrence covered by the JPIA Liability Program which meets all of the following conditions:

- (a) All claims arising out of the occurrence are for property damage only.
- (b) No claim arising out of the occurrence has any apparent potential for related bodily injury allegations.
- (c) The estimated settlement value for all claims arising out of the occurrence does not exceed the District's Self-Insured Retention per occurrence.
- (d) The claim settlement or denial arising out of the occurrence can be concluded within 60 days of when the District became aware that the claim existed.
- (e) A settlement is to be made only when the claim being considered is determined to be based upon liability covered by the JPIA Liability Program.

ARTICLE 16 (~~Renumbered as~~  
~~Article 7A by Resolution 5006~~)

Renamed Article 16A – 1/22/07



**Article 167-B. Insurance Claims Handling Procedures (District-Government Code 905)**

Sec. 167B.1 General.

The liability and immunity of a public agency such as the District is governed by the Government Tort Claims Act set forth in Government Code Section 819 et seq. (the “Act”). Pursuant to the Act, an action for money or damages may not be maintained against the District unless a written claim has first been timely presented to the District and rejected in whole or in part (Government Code Section 905, 905.2, 945.4). Presentation of a claim, when required by law, is a mandatory prerequisite to bringing a legal action against the District, and,

Government Code Section 905 sets forth the rule regarding the presentation of claims and also provides an exemption from said requirement in certain cases including claims by the State or another public entity.

Government Code Section 935 permits the District to establish its own procedures to cover the presentation of those claims against it which are exempted by Section 905, as well as all other claims.

Pursuant to the authority contained in Section 935 of the Government Code, the following claims procedure is hereby established for claims against the District for money or damages that are not governed by any State law.

Sec. 167B.2 Claims Time Limitations.

Notwithstanding the exemptions set forth in Section 905 of the Government Code, all claims against the district for damages or money, where a procedure for presenting such claims is not otherwise provided by State law, shall be presented within the time limitations and in the manner provided by Section 910, et seq. of the Government Code.

Sec. 167B.3 Claims Required.

All claims against the District for money or damages not otherwise governed by the Government Claims Act, California Government Code Division 3.6, Sections 810 et seq., or another state law (hereinafter in this ordinance, “claims”) shall be presented within the time, and in the manner, prescribed by Part 3 of Division 3.6 of Title 1 of the California Government Code (commencing with Section 900 thereof) for the claims to which that Part applies by its own terms, as those provisions now exist or shall hereafter be amended, and as further provided by this article.

Sec. 167B.4 Form of Claim.

All claims shall be made in writing and verified by the claimant or by his or her guardian, conservator, executor or administrator. No claim may be filed on behalf of a class of persons unless verified by every member of that class as required by this section. In addition, all claims shall contain the information required by California Government Code Section 910.

Sec. [467B.5](#) Claim Prerequisite to Suit.

In accordance with California Government Code Sections 935(b) and 945.6, all claims shall be presented as provided in this section and acted upon by the District prior to the filing of any action on such claims and no such action may be maintained by a person who has not complied with the requirements of Sec. [467B.3](#) of this section.

Sec. [467B.6](#) Suit.

Any action brought against the District upon any claim or demand shall conform to the requirements of Sections 940-949 of the California Government Code. Any action brought against any employee of the District shall conform to the requirements of Section 950-951 of the California Government Code.

Sec. [467B.7](#) Severability.

Should any provision of this article, or its application to any person or circumstance, be determined by a court of competent jurisdiction to be unlawful, unenforceable or otherwise void, that determination shall have no effect on any other provision of this article or the application of this article to any other person or circumstance and, to that end, the provisions hereof are severable.

<b>ARTICLE</b> <b>16B</b> <a href="#">(Renumbered as Article 7B by Resolution 5006)</a> New Article added – 1/22/07
---

**Article 178. District Inspections by a Regulatory Agency**

Sec. 178.1 General.

It is the policy of Fallbrook Public Utility District (FPUD) to permit inspections by representatives of county, state and federal regulatory agencies without notice or court order and to cooperate fully. Such inspections shall be accomplished in accordance with the procedures outlined below.

Sec. 178.2 Purpose.

In order to comply with FPUD's Mission Statement to continue to provide for the community of Fallbrook now and in the future:

- (a) A reliable supply and delivery of high quality retail potable water and service, and
- (b) the collection and disposal of wastewater and solids consistent with the optimal use of recycled water,
- (c) use of the most efficient and economical means possible while emphasizing the importance of making customer satisfaction the top priority of operations,

these procedures are designed to provide guidance to District employees to effectively respond to and assist with, regulatory agency compliance inspections. These procedures were developed to provide guidance for District personnel in complying with regulatory inspections without impairing the functioning of District Staff.

Sec. 178.3 Scope.

These procedures shall apply to all FPUD employees who may interact with regulatory agency compliance inspectors in the course and scope of their work. Members of management and employees directly involved in an inspection shall be guided by the examples following.

Sec. 178.4 Responsibilities.

The Engineering Department Head, or his designee, will be the initial contact for any regulatory agency compliance inspector. If no one is available, it will be arranged for the inspector to return at a later time.

If the inspector arrives unannounced, he/she will be asked to wait for the Engineering Department Head. If the Engineering Department Head is unavailable, an available member of management will meet with the inspector to explain the District's policy on unannounced inspections and will then make an appointment for that inspector with the Engineering Department Head or his designee. If the

inspection is of a regulatory nature that requires an inspection without prior notice, a member of management will accompany the inspector.

Sec. 178.5 Procedures.

Before an Inspection:

1. Upon arrival at any District workplace, the inspector will be asked to wait for the Engineering Department Head or his designated District representative. If the inspector contacts a District employee, the employee shall immediately notify their supervisor who will inform the Engineering Department Head. The inspector may be requested to meet with the Engineering Department Head or his representative at a specific location, such as the administrative offices.
2. If the Engineering Department Head or his designated District representative (herein known as the District representative) is not available in a reasonable time, 30 to 60 minutes, the inspector is to be informed of that fact. The inspector should be told that District policy requires the presence of a District representative during the inspection and that the inspection may not proceed without this individual. If no District representative is available, it should be politely suggested that the inspection take place another time or day.
3. The District representative will ask for an opening conference in an attempt to learn the basis for the inspection. The representative should try to limit the inspection to the purpose stated by the inspector.
4. During or upon completion of the opening conference, the inspector should ask consent to begin the inspection. The inspection will then commence in the presence of the District representative.

During the Inspection:

1. The District representative will accompany the inspector throughout the inspection. The representative should be courteous to the inspector and respond to questions only if authorized to do so. The inspector should be informed that the representative is not authorized to speak for the District. Answers should be direct and succinct. Do not volunteer irrelevant and unfavorable information.

*Under no circumstances is the representative, or any other employee, to guess or speculate when responding to questions of an inspector. The only acceptable answer is what the employee knows to be the facts. If the employee has no actual knowledge he should say so. Do not agree with statements made by the inspector, as they may be incorrect.*

2. Inspectors may take photographs, videos, and/or samples of the workplace. The District representative will take similar samples and photographs. The District representative should take notes of everything the inspector says and does, and the identity and summary of testimony of the employees interviewed.

After the Inspection:

1. Upon completion of the inspection, ask the inspector for a closing conference. At this conference ask if any citations will be issued and what regulatory guidelines will be cited. Also try to find out how the citations will be classified (general, serious, etc.). Do not argue with the inspector and do not admit to any violation of regulatory guidelines. It may be helpful to have additional management staff at the closing conference to ensure what the inspector says is fully understood.
2. If the inspector indicates that citations may be issued, call the inspecting agency's District office, that day, and schedule a meeting with the District Manager. The purpose of this meeting is to present your side of the facts and attempt to mitigate any potential citations. During the meeting advise the District Manager that the District is concerned and desires to mitigate and/or avoid reoccurrence.
3. When the inspection is completed, the District representative should meet with District management and District legal counsel. A report should be prepared listing all actions taken during the inspection, everything the inspector said and did, and include all photographs and samples. The report is confidential and copies of this report are not to be circulated.
4. Call JPIA Risk Management, 800/231-5742 and discuss the results of the inspection and the District's potential options.
5. If the District receives a citation(s) it will come by certified mail. If it is decided by management and legal counsel that the District is going to appeal the citation, the District usually has 15 days to file an appeal. Contact JPIA Risk Management and District legal counsel for assistance in appropriately filling out the appeal form. The completed appeal form should be filled out and returned via certified mail.
6. If the District has to appear at an appeal hearing, legal counsel should represent the District. Working with JPIA Risk Management in preparing for the hearing is also recommended.

<b>ARTICLE</b>	<b>17</b>
<b>(Renumbered</b>	<b>as</b>
<b>Article 8</b>	<b>by</b>
<b>Resolution 5006)</b>	
Sec. 17.10 – Rev. 4/95	
Sec. 17.11 – Rev. 4/95	
Sec. 17.12 – Rev. 4/95	
Sec. 17.7 – Rev. 7/97	
Sec. 17.13 & 17.14 – Rev. 11/99	
Sec. 17.5 – added ½	
Sec. 17.16.4 & 17.16.5 – Rev. 6/06	
Secs. 17.7 to 17.15; 17.6 deleted – Rev. 1/11	
All Secs. – Rev. 3/11	

**Article 18.9.            Annexations**

Sec. 18.9.1    Incorporation by Reference.

Ordinance Nos. 73, 92, 122, 226, and 248 are hereby incorporated into the Administrative Code and made a part hereof. Summaries of various provisions of these ordinances follow herein. Reference must be made to a particular ordinance for exact language and legal descriptions of property annexed. The above referenced ordinances refer to the following:

Ordinance No. 73	1950 Annexation
Ordinance No. 92	1958 Annexation
Ordinance No. 122	Airpark Annexation
Ordinance No. 226	Conditions of Service, Waterline Extensions
Ordinance No. 248	Water Service & Water Rates
Resolution No. 1732	Description of Land, Red Mountain Ranch
Resolution No. 1791	Red Mountain Ranch Annexation
Resolution of LAFCO	DeLuz Annexation 1/8/90
Resolution No. 10A	Board of Supervisors, DeLuz Annexation 6/13/90

Sec. 18.9.2    General.

Water Service will be provided to lands within FPUD only after the owner of each parcel to be served has paid an annexation fee. Annexation fees are established for the purpose of equalizing the proportionate obligations, expenditures, and costs of operation between the territory within the District and the territory to be annexed.

*Ordinance No. 92*

*Ordinance No. 226 and 248.*

Sec. 18.9.3    Annexation Payments.

Annexation payments made to the District will be deposited in and held in a special account and will be used by the District toward defraying the costs and expenses of:

- a) Payment of costs and expenses of the District in connection with or incidental to the annexation proceedings.
- b) Payment to the San Diego County Water Authority and Metropolitan Water District of any amounts established by each said Authority and said District in consenting to the concurrent annexation of said territory to said Authority and said District, to be levied as special taxes by said Authority and by said District.
- c) In lieu taxes, from date of Board's approval of annexation to date District taxes may be levied.
- d) Pipelines to service or facilitate service of water to the annexed lands.
- e) Storage facilities.

- f) Improvements in District's facilities to enable it to handle the larger operating load created by the annexation.
- g) Other capital improvements which the Board of Directors may determine would be beneficial to the annexed lands.

Annexed lands share fully in all District assets and liabilities and shall be subject to the same District taxes as the lands already in the District, including taxes for payment of the present bonded indebtedness and other outstanding obligations of the District.

All water rates, rentals, rules and regulations established and to be established by the District for water service and for water delivered by said District, irrespective of the source from which water comes, shall apply uniformly to lands in the annexed areas which have paid their service connection charges in full and to the land already within the District.  
*Ordinance No. 92*

Sec. ~~18~~ 9.4 Conditions for Annexation.

All lands annexed shall be subject to easements for rights of way for District pipelines, power and phone lines and similar facilities used and to be used in connection with the District's operations, as may be required and determined necessary by the Board of Directors of said District, for installing, improving, repairing, replacing and maintaining such District facilities, which rights of way shall be furnished the District without claim or charge for compensation or damages. The District or its party will undertake to locate and maintain such facilities with as little injury as possible to the landowners property consistent with maintaining and operating an efficient system.

All existing operating policies of the District relating to water service and water delivery shall apply to and govern the annexed lands which have completed their service connection charges in full, uniformly with present District lands.

District's distribution pipelines to service the annexed lands will be laid along routes as determined by the District. Pipelines beyond District distribution lines or meters, must be installed, maintained and operated by owners.

Annexation to the District is and will be subject to the condition that the said territory shall also be annexed concurrently to the SDCWA and MWD and shall become and be subject to and be bound by all the terms and conditions fixed by said District and said

Authority respectively, for said annexation and annexation to the District shall become effective and binding only if and when said annexation also has become effective and binding as to the SDCWA and MWD and said lands have been included in and have become a part of the SDCWA and MWD.  
*Ordinance No. 92*

Sec. ~~18~~ 9.5 1950 Annexation.

The 1950 annexation has all been paid into the District. The 1950 annexation was recorded August 1, 1950.  
*Ordinance No. 73.*

Sec. 18.9.6 1958 Annexation.

A petition for annexation to the Fallbrook Public Utility District of unincorporated contiguous territory was filed with the District by not less than 15% of the qualified electors residing in the territory and adopted on September 2, 1958.

In 1958, the District annexed 7,277 acres of land, mainly in the area across the Santa Margarita River, but also taking in all the little windows, which were within the original District boundary that had not paid their annexation fee. Prior to 1958, annexations were not voluntary, and therefore, there was no annexation fee charged at the time. Starting in 1958, a fee of \$250/acre rising to \$450/acre, which was reached in 1970, is a condition for receiving District water. Persons wishing to annex to the District must provide 1) certification of gross acreage by a licensed engineer or surveyor, 2) metes and bounds legal description, and 3) a plat map. (A recorded lot split map showing gross acreage provides all three requirements.)

At the option of the owner of land within the annexed area, service connection charges may be paid for a portion of a single ownership, at the rate of \$450/acre, subject to the following conditions:

- a) The portion of a single ownership so paid up shall consist of not less than 10 acres and shall be rectangular in shape with all four of its side boundaries parallel to Section lines, except sides which are property boundaries.
- b) Water service will not be provided for any portion of a single ownership unless service connection charges have been paid for all planted acreage within such single ownership.

The 1958 annexation was filed with the County Recorder on November 24, 1958.  
*Ordinance No. 92*

Sec. 18.9.7 Airpark Annexation.

In 1966, the Board annexed the Airpark property to the District. The maximum service connection charge of \$400 per gross acre was reached in 1975.  
*Ordinance No. 122.*

Sec. 18.9.8 Red Mountain Ranch Annexation.

In 1978, the District annexed 330 acres of Red Mountain Ranch. Water service connection charges (annexation) began at \$750/acre in 1980 and progressed to \$1,000/acre January 1, 1984. The District will not serve any parcel above the 1400 foot elevation level until such time as all water service connection charges have been paid on all such parcels within the annexed area. Two parcels, 108-010-39 and 40, have been granted a waiver from this agreement.  
*Resolution Nos. 1732 & 1791*

Sec. 18.9.9 DeLuz Annexation.

Formation of the Parent District of the DeLuz Heights MWD occurred on September 25, 1962 by the registered voters. The District then became a member agency of the San Diego County Water Authority on June 28, 1967, and the District Board of Directors established Improvement District No. 1 (I.D. #1) on March 11, 1969 which



consisted of approximately 8,970 acres. Subsequently, a joint petition was filed by 13 individual property owners requesting annexation of approximately 1,580 additional acres to I.D. #1. Improvement District No. 2 (I.D. #2) was formed by the Board of Directors on February 29, 1972 by a special election of individual property owners, which brought the total area to 10,687 acres.

Both I.D. #1 and #2 have coterminous boundaries and voter approved bonds in both areas were used for system improvements in the DeLuz Service Area.

On June 13, 1990, the San Diego County Board of Supervisors and the Local Agency Formation Commission approved the dissolution of DeLuz Heights MWD and its annexation to the Fallbrook Public Utility District, with approval from a majority of the voters. This reorganization included transfer of 12,000 acres of inhabited land, all tangible assets and monies, including cash on hand, monies due but not collected, and all accounts payable and any other obligations, effective June 30, 1990.

*LAFCO Resolution dated 1/8/90 & Board of Supervisors Resolution No. 10A dated 6/13/90.*

Sec. ~~18.9~~.10 Annexation/Detachments Between Adjacent Districts.

Requests for annexation/detachment between Districts is usually done because one District has a pipeline closer to the parcel wishing service, or the other District can provide more adequate service. These requests must be made to both Districts so that annexation/detachment is concurrent. The Board of Directors determines administrative fees, annexations fees, and/or pro-rated share of bonded indebtedness.  
*Ordinance No. 120*

Sec. ~~18.9~~.11 Partial Annexations.

If a landowner has more than 10 acres, he may pay for just 10 acres, provided he submits a legal description of the acreage to be annexed and served with District water. If he has less than 10 acres, he must pay in the whole piece. If more than 10 acres are planted, he must bring in all the planted area. In December of 1976, the Board of Directors authorized the General Manager and/or Secretary to accept a promissory note secured by a Deed of Trust, for annexation fees, if the payment of the fees causes a hardship on the property owner. The owner must pay 20% down with the balance, plus interest at the current general rate, on the promissory note. The balance is paid in four annual payments.

*This section revises Section 4 of Ordinance No. 92*

Sec. ~~18.9~~.12 DeLuz Service Area Annexations.

The fees charged for annexation of land to the DeLuz Service Area are as follows:

- a) Fee for annexation to the DeLuz Service Area, Parent District, is \$1,000.00, plus an acreage fee of \$100.00 per acre.
- b) Fee for annexation to the DeLuz Service Area Improvement Districts I and II is \$1,000.00, plus an acreage fee of \$350.00 per acre.
- c) Fee for annexation to the DeLuz Service Area Parent District and Improvement Districts I and II is \$1,000.00, plus an acreage fee of \$450.00 per acre.

~~18.9~~.12.1 Additional Costs.

The acreage fee shall increase as follows:

Five percent (5%) annually commencing July 1, 1988, and this increase shall be imposed on the first day of July of each calendar year thereafter.

All costs of preparing and processing an Environmental Impact Report, in the event one is required to process the annexation, shall be paid in full by the applicant.

All persons making application for annexation shall deposit with the District the required fees. In the event an environmental impact report is required to be prepared, the estimated cost of preparation and processing of the report shall be deposited with the District prior to the employment of the person or firm which will prepare the report. All additional fees required shall be deposited by the applicant before the District will file the Certificate of Completion to complete the annexation process. Any excess fees deposited will be returned to the applicant upon completion of the annexation.

*DeLuz Heights MWD Ordinance No. 10 (9/8/87)*

Sec. ~~18~~9.13 Improvement District "S".

~~18~~9.13.1 Annexation Fees and Costs.

The fees and costs for annexation of real property to the Fallbrook Public Utility District, Improvement District "S" after April 24, 2012, shall be those set forth below:

- a) Costs: The amount of Three Hundred Dollars (\$300.00) plus the current LAFCO processing fees shall be paid to the District at the time of application for processing annexation of real property to Improvement District "S".

The costs shall include any fees or costs required to be deposited with other governmental agencies in order to process the annexation. The District shall not approve the annexation until all required fees and costs have been deposited with the District.

- b) Fees: Effective April 24, 2012, an annexation fee of Nine Thousand Eight Hundred Sixty-Seven (\$9,867) dollars shall be charged for each equivalent dwelling unit permit for sewer service granted for service within the annexed territory at any time after the territory is annexed to the District. This fee shall be deposited with the application for issuance of a sewer service permit for service within the annexed territory.

~~18~~9.13.2 Adjustment Review.

The fees and costs fixed by this Article of the Administrative Code shall be reviewed every five (5) years for the following

fiscal year and the fees and costs may be adjusted to be effective with the commencement of the fiscal year.

**ARTICLE 18** ([Renumbered as Article 9 by Resolution 5006](#))

- Sec. 18.11 – Rev. 2/93
- Sec. 18.1, 18.3-4 – Rev. 4/93
- Sec. 18.12 – Rev. 11/94
- Sec. 18.13 – Rev. 6/95
- Sec. 18.13.6 – Rev. 9/96
- Sec. 18.13.4 – Rev. 6/97
- Sec. 18.13.5 – Rev. 6/97
- Sec. 18.13.6(b) – Rev. 6/97
- Sec. 18.13.2,3,4,5,6(b) – Rev. 9/98
- Sec. 18.13 – Rev. 4/12
- Secs. 18.2, 18.3 – Rev. 7/19

**Article 19 10.            Water Service Connections & Rules for Delivery of Water**

Sec. ~~19 10.1~~            Definitions.

For the purpose of this Administrative Code and the regulation of water service by the Fallbrook Public Utility District, the following definitions are adopted:

The word "District", as used herein shall mean and refer to the Fallbrook Public Utility District of San Diego County, California. Fallbrook Service Area (FSA) will indicate that area known as Fallbrook Public Utility District prior to July 1, 1990. The DeLuz Service Area (DLSA) will indicate that area known as Improvement Districts I and II of DeLuz Heights Municipal Water District prior to July 1, 1990.

The word "Consumer", as used herein, shall mean and refer to every individual, corporation, association, farm, or place of business to whom or to which water is served by the District.

The word "Unit", as used herein, shall mean and refer to each of the following:

1.     A single family residence.
2.     A single business establishment.
3.     A single farm.
4.     One hotel or motel suite with bath and kitchen.
5.     Two hotel or motel suites without kitchen but with private bath.
6.     Four hotel or motel suites without private bath.
7.     One trailer space.
8.     In multi-family dwellings, each apartment with kitchen and bath.
9.     Each dormitory or labor camp facility.
10.    Nursing home.

The word "rates," as used herein, shall mean the compensation fixed by the Directors by Ordinance for water delivered to the consumer or for the cost of installing and maintaining meters, main line extensions and any and every appliance, fixture or connection used by said District in delivering water to said consumer.

The term "service connections", as used herein, shall designate the distribution system extension to the meter assembly and the connection to the consumer's line which shall previously have been provided to the location and to the specifications set by the District.

The term "Agricultural purposes", as used herein, shall mean the growing or raising, in conformity with recognized practices of husbandry, for the purposes of commerce, trade, or industry, of agricultural, horticultural, or floricultural products, and produced (1) for human consumption or for the market, or (2) for the feeding of fowl or livestock produced for human consumption or for the market, or (3) for the feeding of fowl or livestock for the purpose of obtaining their products for human consumption. Water used for agricultural purposes may be eligible for either the Commercial Agricultural Water Rate or Permanent Agricultural Water Rate (PSAWR) if they meet additional requirements outlined below.

The term "Commercial Agricultural", as used herein, shall mean the use of water through a single service connection for agricultural purposes without participation in the PSAWR

discount program, on land having an area of not less than one acre fully utilized for agricultural purposes.

The term "Domestic purposes", as used herein, shall mean the use of water for residential (up to and including two units) purposes and businesses that use water for incidental domestic purposes only. If a commercial agricultural parcel has a permanent residence, the first 5 units of water provided each month is considered for domestic purposes regardless of the number of residences on the property. If a PSAWR parcel has a permanent residence, the first 17 units of water provided each month is not eligible for the PSAWR program rate. Parcels using water for Agricultural purposes that are eligible for the commercial agricultural or PSAWR water rate programs will be classified as either Agricultural-Domestic with PSAWR Discount (AT) or Agricultural Commercial-Domestic (CB);

The term "Large Lot domestic purposes", as used herein, shall mean the use of water through a single service connection for residential (up to and including two units) purposes on parcels of one acre or more.

The term "Commercial purposes", as used herein, shall mean the use of water through a single service connection for the operation of the business or maintaining the landscaping of non-residential property.

The term "Government purposes", as used herein, shall mean the use of water through a single service connection for any political subdivision property.

The term "Multi-Unit purposes", as used herein, shall mean the use of water through a single service connection for master-metered residential housing of more than two living units.

The term "Standby Service", as used herein, shall mean a meter which has been locked at the request of the customer and which account balance remains current. Accounts may also be locked and placed on "standby service" in the event that the unpaid balance on the account becomes delinquent for a period of 90 days and/or if the District is made aware of foreclosure or vacancy of said property. A fee of \$50 to lock the meter and initiate standby service will be charged to the account and the account will be charged all applicable monthly standby charges.

The term "San Diego County Water Authority Permanent Special Agricultural Water Program" or "PSAWR", as used herein, shall mean the Program described in Section ~~19~~10.11.

The term "Construction Meter Service", as used herein, shall mean the temporary use of water for construction from a meter installed on a fire hydrant.

The term "Temporary Ag Service", as used herein, shall mean the temporary use of water solely for the growing of annual crops through a temporary connection.

The term "Recycled Water System", as used herein, shall mean water that is defined in Title 22, Division 4, Chapter 3, Article 60301, paragraph 8, of the California Administrative Code and shall mean water which, as a result of filtration and disinfection of domestic wastewater, is suitable for a direct beneficial use or a controlled use that otherwise would not occur.

Sec. ~~19~~10.2                      Remote Meter Agreements.

A Remote Meter Agreement is an agreement between the District and a consumer that a water meter will be installed at a location remote from the property to be served where the District does not intend to extend the District distribution system to abut the said property, and that the consumer is responsible for extending his own private line from the meter to his property and obtaining the permanent easements required for such extension.

Sec. ~~19~~ 10.3 Temporary Service Agreements.

A Temporary Service Agreement is a recorded agreement between the District and a consumer that a meter will be placed temporarily at a location remote from the property to be served, where the District intends, at some future date, to extend the District distribution system to abut the property described in the agreement, and that the consumer is responsible for extending his own temporary private line from the meter to his property, and obtaining whatever temporary easements are required for such extension. Such agreements shall establish the financial obligations of the consumer related to the future installation costs of the District's distribution system and the cost of relocation of the meter, and shall be binding upon the signatory and all successor owners of said property.

If the customer's obligation is to be secured with a promissory note and deed of trust, the terms will be based on the 10-year Treasury Bill rate plus 2%. Interest will be recalculated annually on the anniversary date of the recorded Trust Deed and will be compounded annually on the same anniversary date.

Failure to comply with the terms of the agreement shall be cause for termination of water service to said property and the basis for establishing a lien against the property for collection of any amounts due the District. Upon change of ownership, any parcel receiving water service under a Temporary Service Agreement will be required, as a condition of continued service, for the new owner to enter into a new Temporary Service Agreement with the District.

Sec. ~~19~~ 10.4 Engineering Fees.

Sec. ~~19~~ 10.4.1 Plan Check Fees.

- A) Plan checks less than 500 lineal feet, water or sewer, \$500 each.
- B) Plan checks 500 lineal feet to 1,000 lineal feet, water or sewer, \$1,000 each.
- C) Plan checks greater than 1,000 lineal feet, \$1,000 each, plus .50 cents per lineal foot thereafter.

Sec. ~~19~~ 10.4.2 Fees for District to Inspect Contractor Installed Facilities

- A) Water Meter Service Line Installation
  - ¾" to 2" 5 hours @ \$106.31 = \$531.55
  - 3" and larger 9 hours @ \$106.31 = \$956.81
- B) Fire Hydrant Installation 9 hours @ \$106.31 = \$956.81
- C) Fire Service Installation 9 hours @ \$106.31 = \$956.81

If the sum of the inspection fees for a project is greater than \$3,000, the inspection will be done on a time and material basis and a deposit for the estimated cost will be paid prior to

start of construction. Inspection fees will be adjusted annually based on the Engineering News Record (ENR) Construction Cost Index (CCI) of February. Staff will report back to the Board no less than every five (5) years with analysis comparing current fees to calculated fees.

Sec. ~~19~~ 10.5                      Rules for Service of Water.

The following rules for the service of water by the District to the consumer, either within or without the District, are hereby established:

All parcels desiring water must abut a District pipeline, and all meters will be located on the parcel being served unless the General Manager approves a Remote Meter Agreement, or the Board of Directors authorizes a Temporary Service Agreement subject to certain conditions as described in Section ~~19~~ 10.3.

Each consumer desiring water furnished by the District shall furnish a plat of the property to be served, individually file a written application for such service, and in the form provided by the District, shall state the location, the number of acres served, the legal owner thereof, the purpose for which water is to be used and such other data regarding consumer's water production and use practices as required by the District. Based on the information provided, and verified by physical inspection if appropriate, each application will be assigned a user code: Agricultural with PSAWR Discount (AS); Agricultural Commercial (CA); Agricultural-Domestic with PSAWR Discount (AT); Agricultural Commercial-Domestic (CB); Domestic (D); Commercial (C), Government (G); or Multi-Unit (M) in accordance with the definitions provided in Section 19.1.

By making such application and upon approval thereof by the General Manager, or his designee, the application and the acceptance shall constitute a contract, the effect of which shall bind the applicant to pay all rates then or thereafter prescribed by the District for water service and to comply with all the rules and regulations with respect to service, a breach of any of which will authorize the District to discontinue water service immediately without notice or recourse and to levy such charges as otherwise provided for in this ordinance for resumption of service.

In addition, the effect of this contract shall be such as to bind the applicant to pay reasonable attorney's fees as fixed by the court where the District is required to take legal action to enforce collection of any charges incurred under this service.

The District reserves the right to determine the size and location of all service connections and may to that extent, where deemed for the best interests of the District, reduce the size, change the location or the pressure of the service connection without notice or recourse.

Sec. ~~19~~ 10.6                      Meter and Service Line Installations.

Before any service connection with the water distribution system of the District is made, the District shall collect from the applicant who desires water service an installation charge as set forth below. A connection fee based on the demand factor shall be paid in addition to the installation charges and is described in Article ~~20~~ 11 of this Administrative Code. Reclaimed meter and service line connections shall be capitalized as part of the project and not charged to the customer. Installation charges will be adjusted annually based on the ENR (Engineering News Record) Construction Cost Index (CCI) of

February. Staff will report back to the Board of Directors no less than every five (5) years with analysis comparing fees to actual costs.

<u>Meter Size</u>	<u>Meter and Service Line*</u>	<u>Meter Only on Existing Service Line</u>	<u>Service Line Only*</u>
3/4"	\$2784	\$468	\$2318
1"	\$2962	\$644	\$2318
1-1/2"	\$4017	\$1022	\$2995
2"	\$4818	\$1178	\$3640
3", 4" or 6"	Cost	Cost	Cost
Recycled, any size	No charge	No charge	No charge

\* If paving for a service line is less than or equal to 15 feet, there is an additional charge of \$1807 . If paving for a service line is greater than 15 feet and less than 30 feet, there is an additional charge of \$3615 . If County road inspection is required, there is an additional fee of \$1402.

Sec. 19 10.7 Meter Relocation Fees.

<u>Meter Size</u>	<u>Relocation and Service Line*</u>
3/4"	\$3,203
1"	\$3,364
1-1/2"	\$4,041
2"	\$4,645

\* If paving is required up to 30 feet, there is an additional fee of \$4746 . If County road inspection is required, there is an additional fee of \$1402.

Sec. 19 10.8 Connection/Capacity Fees.

A connection fee shall be paid at the time meter service is applied for, for all permanent service connections, which fee shall be in addition to the charges made for the actual cost of labor and materials necessary to make the physical connection to the water system. The capacity fee for the connection is based on the demand that could be placed on the District's water system by reason of the connection. The extent of demand will be determined on the basis of the size of the water meter necessary to provide the estimated quantity of water usage for the connection. The demand factor for each meter size shall be calculated on the basis of the rated capacity of each size of meter divided by the rated capacity of a 3/4" meter at a pressure of 40 pounds per square inch (20 gpm), hereinafter referred to as an "equivalent meter unit" (EMU) as defined by SDCWA. Connection/ capacity charges will be adjusted annually based on the ENR (Engineering News Record) Construction Cost Index (CCI) of February. Staff will report back to the Board of Directors no less than every five (5) years with analysis comparing current fees to calculated fees.

Effective January 1, 2020, the schedule of capacity fees based on the demand factor of each meter size shall be as follows:



<u>Meter Size</u>	<u>SDCWA Demand Factor (EMU)</u>	<u>Capacity Fee</u>
3/4"	1	\$5,778
1"	1.6	\$9,247
1-1/2"	3	\$17,336
2"	5.2	\$30,050
3"	9.6	\$55,477
4"	16.4	\$94,770
6"	30	\$173,365

The capacity charge for a meter size greater than 6 inches shall be a basic charge for one (1) EMU multiplied by one of the following factors:

8".....factor .....	52.0
10".....factor .....	78.0
12".....factor .....	132.0

Sec. ~~19~~ 10.8.1 Removal of Meters.

An owner of a parcel who has a meter and is not required to have District water for their parcel can request to have their meter removed and discontinue service. A fee of \$100 will be charged for meter removal. Once the meter is removed, if service is later requested for the parcel, it will be subject to all the fees identified in Article ~~19~~ 10, including installation and connection/capacity fees as if it is a new service.

The following procedure will be followed when discontinuation of service is requested:

1. The District will verify that the parcel does not have a residence or that another supply is available for the residence. If District water service is necessary as a health and safety concern for the residence then the meter cannot be removed.
2. The parcel owner shall sign a form that will be recorded on their deed indicating that water service was discontinued and re-establishing service will require payment of all fees similar to any other new water customer.
3. The District will remove the meter based on the fee established for meter removal.
4. The owner will be deleted from the District's customer database and no further monthly operations, capital improvement or standby fees will be charged to the parcel. The parcel will be subject to Water Availability Charges, unless the parcel owner requests deferral in accordance with Article ~~24~~ 15.
5. If the water service is requested in the future for this parcel it will be similar to any other parcel without water service and subject to all necessary fees including installation and connection/capacity fees.

Sec. ~~19~~ 10.8.2 Meter Testing Costs.

The District will provide meter testing upon request by ratepayers. A meter is considered accurate according to AWWA standards if it measures 98.5% to 101.5% of actual usage. If, after the customer's request for testing, the meter is determined to be accurate, the customer will be charged the following fee based on the size of the meter:

<u>Meter Size</u>	<u>Fee for testing</u>
3/4" – 1"	\$123
1 1/2" – 2"	\$165
Over 2"	To be tested by an outside agency at a cost to be determined on actual time and materials.

If the meter is inaccurate, the District will absorb the cost of the test and make the appropriate exchange or repair to said meter to AWWA standards of accuracy. These charges will be adjusted annually based on the ENR (Engineering News Record) Construction Cost Index (CCI) of February.

Sec. ~~19~~ 10.8.3 Adjustment to Fees for Meters and Connections.

Service requests after advance payments for meters and connection fees shall be adjusted to the District's current schedule after six (6) months from the payment date(s).

Sec. ~~19~~ 10.9 Credit for Connection Fees and Fees for Increased Meter Size.

Owners of parcels presently receiving water service through a District meter that subdivide their property and apply for additional meters to new legal parcels will be given credit for connection charges if they reduce their demand by requesting a smaller meter for their original service.

Owners of parcels presently receiving water service through a District meter that are not in the process of subdividing their land, but require a larger meter service connection due to a change in land use, shall pay a connection fee equal to the difference between connection fees for the old and new meters in accordance with the schedule in Sec. ~~19~~ 10.8.

Sec. ~~19~~ 10.10 San Diego County Water Authority Connection Fees.

The Board of Directors of the San Diego County Water Authority (SDCWA) announced an administrative adjustment to capacity charges on all meters purchased on or after January 1, 2020 within the boundaries of the SDCWA.

The System Capacity Charge for a meter size of one (1) inch or greater shall be the basic charge of \$5,312 multiplied by a Factor that is based upon additional meter capacity.

<u>Meter Size</u>	<u>Factor</u>	<u>System Capacity Charge</u>	<u>Water Treatment Capacity Charge</u>	<u>TOTAL</u>
Less than 1"	1.0	\$5,312	\$148	\$5,460
1"	1.6	\$8,499	\$237	\$8,736
1-1/2"	3.0	\$15,936	\$444	\$16,380
2"	5.2	\$27,622	\$770	\$28,392
3"	9.6	\$50,995	\$1421	\$52,416
4"	16.4	\$87,117	\$2,427	\$89,544
6"	30.0	\$159,360	\$4,440	\$163,800
8"	52.0	\$276,224	\$7,696	\$283,920
10"	78.0	\$414,336	\$11,544	\$425,880
12"	132.0	\$701,184	\$19,536	\$720,720

The System Capacity Charge is the cost for the conveyance and storage facilities necessary to operate the delivery system.

The Water Treatment Capacity Charge is the cost for the connection to the 50 MGD (million gallons per day) regional water treatment facility. The Water Treatment Capacity Charge is an additional charge of \$148 for each new meter of a size less than one inch and a corresponding increase for larger meters.

The member agency shall determine the size of the water meter to serve any property within its jurisdiction. In the event an agency calculates the water demand by the equivalent dwelling unit (EDU) method, the County Water Authority's capacity charge will be collected based on the size of meter actually installed to meet flow demand.

No capacity charge shall be imposed for a water meter permanently connected to a reclaimed water system and measuring reclaimed water. If a water user converts a water meter to permanently measure only reclaimed water, the capacity charge previously collected for the meter shall be refunded upon written request from the water user and verification by the member agency in which the water user is located that the meter is permanently connected to the reclaimed water supply and is measuring reclaimed water. The refund shall be in the amount of the capacity charge actually collected.

All claims for refund permitted shall be presented within one year of the date of the event justifying the refund.

Sec. ~~19~~ 10.11 San Diego County Water Authority Permanent Special Agricultural Water Program Administration

Sec. ~~19~~ 10.11.1 Purpose.

The San Diego County Water Authority Permanent Special Agricultural Water Program (PSAWR) provides discounted wholesale supply and treatment pricing for qualified agricultural users within its service area on the basis that participants receive non-firm, interruptible . This section of the District's Administrative Code establishes the rules and regulations for Administration of the SDCWA PSAWR within the Fallbrook Public Utility District (District).

Sec. ~~19~~ 10.11.2 Qualification.

New eligible customers may sign up to receive the PSAWR Program water rate at any time during non-service limitation periods. Non-service limitation periods are when there are no service limitations imposed to PSAWR member agencies such as a cutback from Metropolitan or emergency situations. The qualifications for water use under the San Diego County Water Authority's (SDCWA) PSAWR program are as follows:

In accordance with the San Diego County Water Authority policies, including but not limited to the Permanent Special Agricultural Water Rate Program Handbook, Fallbrook Public Utility District and Owner acknowledge that to participate in the PSAWR water rate, agricultural customers must meet the following criteria:

1. Grow or raise – for commercial purposes – products of an agricultural, horticultural, or floricultural nature.

2. The Commercial Agricultural Operation must be included on one of the following lists (ONLY 1 REQUIRED):
  - Grower’s List
  - Active Certified Producers List
  - Organic Producers List
  - Regional Board General Agricultural Order Enrollment List

Sec. ~~19~~ 10.11.3      Certification and Recertification.

Individuals applying for participation in the SDCWA PSAWR shall certify, a that they are the owner or authorized agent of the owner of the property to receive water under the SDCWA PSAWR and further certify that their respective water usage will meet the qualifications set forth in Section ~~19~~ 10.11.2 and as modified from time to time by SDCWA. Upon submission and approval of the application for participation in the PSAWR, applicants shall be classified as either “Agricultural” or “Ag / Domestic”, and be eligible to receive the established water rate for the assigned classification. Participants may be subject to periodic re-certification as determined by the SDCWA, or the District.

Sec. ~~19~~ 10.11.4      Acknowledgement.

Individuals participating in the PSAWR shall acknowledge that:

- a) Water received under the PSAWR is a non-firm, interruptible supply, subject to early and accelerated mandatory supply reduction as is from time to time determined necessary by MWD and/or the SDCWA.
- b) Water use under the PSAWR supply is subject to periodic data examination and field audits and participants agree to respond in a timely manner to requests for information and access to properties receiving water under the PSAWR.
- c) Failure to respond in a timely manner to information requests, associated data examination and field audits or recertification, or failure to provide reasonable access to properties receiving water under the PSAWR will result in automatic removal of the subject property from the PSAWR, subject to the conditions set for in subsection ~~19~~ 10.11.5(c) of this Article, and subsequent water use on the property will be classified and billed as “Domestic” or “Commercial”.
- d) If, as a result of data examination and/or an audit, it is determined that PSAWR supply was used on property and/or for purposes not meeting the qualifications established by SDCWA, then said usage may be subject to assessment of retroactive supplemental water rates, penalties and charges as required by the SDCWA, or the District, which the participant agrees to pay.
- e) If data examination and/or an audit determines that the subject property and/or water use on the property does not qualify for the PSAWR, then the property and associated water account will be removed from the PSAWR as provided for and subject to the conditions in sub-section ~~19~~ 10.11.5(c) of this Article, and subsequent water use on the property will be classified and billed as “Domestic” or “Commercial”.

Sec. ~~19~~ 10.11.5      Exit and Re-entry into the PSAWR Program.

- a) PSAWR customers who knowingly no longer meet the participation qualifications of the PSAWR are required to inform the District within 30 days. Failure to provide notice of a change in eligibility within 30 days will result in retroactive assessment of the SDCWA M&I water rates and charges for the period of ineligibility in which the PSAWR water rate was received. .
- b) Customers electing to voluntarily exit the PSAWR will still be subject to PSAWR-related reductions if the customer exiting utilized PSAWR water in the base year for a mandatory reduction in a subsequent year. PSAWR customers may not voluntarily exit during periods of water shortage allocations and mandatory reductions for the duration the level is implemented or for three years, whichever is a shorter period, or during period in which there is substantial threat of a mandatory water supply reduction.
- c) Participating customers may opt-out of the PSAWR Program at any time during non-service limitation periods. If a PSAWR Program account has opted out, the parcel number associated with that retail meter account will not be allowed to re-enter the PSAWR Program unless the parcel legally changes ownership in an arm's length commercial transaction verified by the District..

Sec. ~~19~~ 10.11.6 Implementation of Mandatory PSAWR Supply Reductions.

Actual implementation of mandatory supply reductions shall be based upon levels of reduction required the SDCWA. To achieve the required levels of use reduction and avoid the maximum penalty possible any operational or financial sanctions which may be imposed on the District by the SDCWA, the District will utilize one or a combination of methods, including timely notice of pending reductions, water management information dissemination, individual participant water budgets and use reduction targets, assessment of financial disincentives, and individual meter flow reduction devices.

Sec. ~~19~~ 10.12 Installation or Extension Line Costs.

In connection with the installation or extension of water distribution lines, the District may concurrently install service lines for adjoining land parcels. The cost of the service lines together with the pipeline extension costs will be borne by the owners.

Where because of any unusual circumstance service connections involve extra expense to the District, an additional deposit or payment based upon the actual cost of such connection as determined by District staff, may be required by the District.

Sec. ~~19~~ 10.13 Customer Valve.

There shall be a stopcock or wheel valve in every attachment between the meter and the main next to the meter which said stopcock or wheel valve and the meter and other devices and fittings, including the meter box supplied by the District, shall be for the exclusive use and under the control of the District.

There shall be a stopcock or wheel valve in each service connection located on the consumer's side of the meter, at a point to be designated by the District, which stopcock or

wheel valve shall be for the use of the consumer and shall be referred to as the “customer valve.”

The District has responsibility to repair or replace facilities up to and including the customer shut off valve. Repair and maintenance of facilities beyond the customer valve is the responsibility of the customer.

The District is not responsible for water loss due to leaks or other problems on the property side of the customer valve.

If there is an emergency, the District, at its discretion, can make temporary repairs and charge the customer a minimum of \$50. However, the District is under no obligation to repair leaks beyond the customer valve and assumes no long term liability for those repairs. It is recommended that the customer obtain the services of a licensed plumber to make permanent repairs.

Sec. ~~19~~ 10.14            Water Must Pass Through Meter.

All water sold by the District and used by any consumer must pass through that customer’s meter, and no delivery will be made by the District except through that customer’s meter. In the event that it should be discovered that water is served to any premises by means of a bypass or any other mechanical device or instrument which permits water to be served other than through that customer’s meter, the District shall have the right to immediately cut off the supply of water to said consumer until the person guilty of such conduct shall have reimbursed the District for the cost, as determined by the District, of the water so illegally used. The District shall assess a \$100 penalty, per incident, to any person who steals water in any amount.

Sec. ~~19~~ 10.15            Mains, Service Pipes, Equipment Belonging to District.

All water mains, extensions of service pipes, meters, and all other equipment used in the delivery of water to any meter, including the meter and the customer valve shall belong to and be the property of the District, and shall be maintained and repaired by the District.

Customer shall permit reasonable access to the meter and valves to effect said maintenance and repairs and to read the meter. Replacement shall be made by the District when such equipment is rendered unserviceable through reasonable use thereof.

However, the cost of replacements, repairs, or adjustments of any equipment of said District, including meters, when rendered necessary by any act, negligence or carelessness of the consumer, shall be made by the District at the expense of the consumer.

Sec. ~~19~~ 10.16            Meter Area Clean and Consumer Line Free from Leaks.

Every consumer of water must keep his service pipes, valves, fixtures, and all other apparatus beyond that belonging to and serviced by the District in good repair and free from leakage at his own expense and he will be responsible for all damages which may result from failure to comply with this rule.

Sec. ~~19~~ 10.17            Fires.

In the event that fires should take place within the District, where

it is necessary to use the distribution mains of the District to supply water to extinguish such fires, the District may temporarily discontinue service to any meter, and the affected consumer shall not be permitted to use water from any of the District mains until such fire is completely extinguished.

Sec. ~~19~~ 10.18            Access to Meters.

No person shall place or cause to be placed on or about or around any meter, hydrant, stopcock or service connection of any of the mains, pipes or water-works of the District any material of any kind which may serve or act as an obstruction to the free access or use of such meter, hydrant, stopcock or service connection. Upon failure to remove such obstruction after reasonable notice, the District shall have the right to have the water shut off and keep the same from being turned on again until such obstruction is removed and the necessary fee for turning on said water paid to the District.

Sec. ~~19~~ 10.19            Temporary Discontinuance of Service for Repairs, etc.

The District reserves the right at any time to discontinue the service of water from its mains to water consumers for the purpose of making repairs or extensions to all parts of the system under the operation and control of the District or for any other purpose which may be found necessary by the District in order to properly maintain its system. In such case, the District will, if practicable, give notice to the consumer of such interruption in service.

Sec. ~~19~~ 10.20            Allowances or Rebates.

No allowance or rebates in rates or charges shall be made under any circumstances, except as hereinafter in this Administrative Code authorized, and the rates herein prescribed for service of water shall be a charge against any and all property as hereinbefore specified, until the District shall receive written notice of request to discontinue the water to such property, provided, however, that notwithstanding such written notice or request, the District shall still collect the minimum amount prescribed by this Administrative Code for the standby service as long as the meter is in place.

Sec. ~~19~~ 10.21            Water Served to Others.

It is hereby declared to be a violation of the consumer's contract for which the District shall have the right to discontinue the service of water, if any water consumer shall be found to have served water to a consumer whose water has been shut off for breach of any of the provisions of this Administrative Code.

The District or representatives of the District shall have the right at all times to have free access to all parts of the premises of the consumer supplied with water to inspect the water system maintained by the customer.

Sec. ~~19~~ 10.22            Backflow Prevention Devices.

In accordance with Title 17 of the California Administrative Code, backflow prevention devices to protect the District distribution system from possible contamination will be owned and maintained by the District. The device will be located at the service connections. The type of protection that shall be required to prevent backflow into the public water supply shall be commensurate with the degree of hazard that exists on the customer premises. The type of protective device that will be required (listed in an

increasing level of protection) includes: Double check Valve Assembly-(DC), Reduced Pressure Principle Backflow Prevention Device-(RP) and an Air gap Separation-(AG). The customer may choose a higher level of protection than required by FPUD. The minimum types of backflow protection required to protect the public water supply, at the water user's meter connection to the property with various degrees of hazard, are listed below. Situations not covered in the listed below shall be evaluated on a case-by-case basis and the appropriate backflow protection shall be determined by FPUD.

Sec. ~~19~~ 10.22.1 Type Of Backflow Protection Required.

1. An (AG) is required on premises where there are waste water pumping and/or treatment plants and there is no interconnection with the potable water system. This does not include a single-family residence that has a sewage lift pump. A RP may be provided in lieu of an AG if approved by the District.
2. An (AG) is required on premises where hazardous substances are handled in any manner in which the substances may enter the potable water system. This does not include a single-family residence that has a sewage lift pump. A RP may be provided in lieu of an AG if approved by the District.
3. An (RP) is required on premises where there are irrigation systems into which fertilizers, herbicides, or pesticides are, or can be, injected. Any sign of injection systems on the property, including unused systems will require an (RP).
4. Auxiliary Water Supplies--Any water supply other than that received from a public water system.
  - A) (AG) is required on premises where there is an unapproved auxiliary water supply which is interconnected with the public water system. A RP or DC may be provided in lieu of an AG if approved by the District.
  - B) An (RP) is required on premises where there is an unapproved auxiliary water supply and there are no interconnections with the public water system.
5. Recycled Water
  - A) An (AG) is required on premises where the public water system is used to supplement the recycled water supply.
  - B) An (RP) is required on premises where recycled water is used, and there is no interconnection with the potable water system.
  - C) An (RP) is required on residences using recycled water for landscape irrigation as part of an approved dual plumbed use area. If the District is also the supplier of the recycled water, to utilize an alternative backflow protection plan that includes an annual inspection and annual shutdown test of the recycled water and potable water systems.



## 6. Fire Protection Systems

- A) An (RP) is required on premises where the fire system is directly supplied from the public water system and there is an unapproved auxiliary water supply on or to the premises (not interconnected).
  - B) An (AG) is required on premises where the fire system is supplied from the public water system and interconnected with an unapproved auxiliary water supply. A RP may be provided in lieu of an AG if approved by the District.
  - C) An (RP) is required on Premises where the fire system is supplied from the public water system and where either elevated storage tanks or fire pumps which take suction from private reservoirs or tanks are used.
  - D) An (RP) is required on Premises where the fire system is supplied from the public water system and where recycled water is used in a separate piping system within the same building.
  - E) A (DC) is required for single family residence with fire protection system. The (DC) needs to be installed and maintained by the property owner.
- 7. An (RP) is required on premises where entry is restricted so that inspections for cross-connections cannot be made with sufficient frequency or at sufficiently short notice to assure that cross-connections do not exist.
  - 8. An (RP) is required on premises where there is a repeated history of cross-connections being established or re-established.
  - 9. An (RP) is required where adjacent parcels under common ownership are served by more than one meter. RP devices will be required at each meter.
  - 10. An (RP) is required on all new agricultural (AS), agricultural/domestic (AT), commercial agricultural (CA), or commercial agricultural domestic (CB) services. An RP will be installed by the District only with the new meter services.
  - 11. Property owners who appeal to the District to change classification from a classification other than agricultural (AS, AT, CA, CB) will be required to install a Reduced Pressure Backflow Preventer at the property owners expense. See Section ~~19~~ 10.22.3 & 4.

Evaluation of Hazard. The District shall evaluate the degree of potential health hazard to the public water supply which may be created as a result of conditions existing on a user's premises. The District, however, shall not be responsible for abatement of cross-connections which may exist within a user's premises. As a minimum, the evaluation should consider: the existence of cross-connections, the nature of materials handled on the property, the probability of a backflow occurring, the degree of piping system complexity

and the potential for piping system modification. Special consideration shall be given to the premises of the following types of water users:

- A) Premises where substances harmful to health are handled under pressure in a manner which could permit their entry into the public water system. This includes chemical or biological process waters and water from public water supplies which have deteriorated in sanitary quality.
- B) Premises having an auxiliary water supply, unless the auxiliary supply is accepted as an additional source by the District.
- C) Premises that have internal cross-connections that are not abated to the satisfaction of the District.
- D) Premises where cross-connections are likely to occur and entry is restricted so that cross-connection inspections cannot be made with sufficient frequency or at sufficiently short notice to assure that cross-connections do not exist.
- E) Premises having a repeated history of cross-connections being established or reestablished.

Sec. ~~19~~ 10.22.2      Backflow Device Installation on New Services.

The District shall install Reduced Pressure Backflow Preventers on new potable water meter services when applicable. (see Type of Backflow Device Protection Required)

An additional charge will be made for installation of backflow prevention devices as follows:

Reduced Pressure Principle Devices (installed along with new meter)

For each ¾ inch meter	\$475
For each 1 inch meter	\$560
For each 1-1/2 inch meter	\$1,034
For each 2 inch meter	\$1,251
For each 3, 4 or 6 inch meter	Cost

Backflow / RP device charges will be adjusted annually based on the ENR (Engineering News Record) Construction Cost Index (CCI) of February. Staff will report back to the Board of Directors no less than every five (5) years with analysis comparing fees to actual costs.

Sec. ~~19~~ 10.22.3      Reduced Pressure Backflow Preventer Retrofits.

Retrofit: Installation of a Backflow device after the service connection has been established.

General Design Considerations.

- A) The design and construction of the backflow prevention assembly shall meet the requirements called for in this specification.
- B) The nominal size of the backflow prevention device shall be equal to the size of the purchased meter. For example, a (1") meter shall have a (1") backflow prevention device.
- C) The assembly shall include same size valves located on either side of the backflow prevention assemblies. Four test cocks shall be appropriately located on the assembly for testing and certification.
- D) The nominal size of reduced-pressure principle detector assemblies shall be as shown on the Approved Plans or as directed by the Fire Department of jurisdiction.
- E) Enclosures and concrete slabs shall be provided only as shown on the Approved Plans or as required by the agency of jurisdiction.

Sec. ~~19~~ 10.22.4      Reduced Pressure Backflow Preventer Device Retrofit –  
Installed by Property Owner

The property owner shall be responsible for the Reduced Pressure Backflow Device Retrofit. Once the device is installed, passes the backflow test, and meets the District’s standards the device will become the property of the District. The device will be charged the standard monthly service charges and will be tested annually.

Upon notification by the District that a Reduced Pressure Backflow Device is needed, the property owner will have sixty (60) days to comply. After sixty (60) days, the District shall have the right to discontinue water service and charge a fee of fifty dollars (\$50) to lock the meter. A fee of one hundred (\$100) will be charged for broken or damaged locks. Damage to corp or angle stop in attempt to restore services will be billed at actual time and material and added to the water bill. The water service will be restored only after the fees are paid and the device is installed, passes, and meets the District standards.

Installation.

- 1) Installations of retrofit backflow devices will not be performed by District Personnel and is the sole responsibility of the property owner.
- 2) Forty-eight (48) hours prior to installation, the Backflow Department will be notified at (760) 728-1125, extension 1129. Installations and inspections will be scheduled Monday through Thursday’s only – excluding all District holidays. District personnel will shut off the angle stop before the meter. If the installer or property owner shuts off the angle stop and causes damage, the installer and property owner will be responsible for damages. The damages will be calculated at a time and materials rate.
- 3) Installation shall comply with the latest edition of the Uniform Plumbing Code and applicable District requirements.

- 4) Backflow prevention assemblies shall be installed in accordance with the District's standard drawings.
- 5) Water service and fire service shut-off valves will be secured closed during installation until an approved backflow prevention device is installed and tested in compliance with this specification.
- 6) When static pressure exceeds 175 psi, a pressure-reducing valve may be installed. Please contact the Backflow Department for determination of necessity.
- 7) After installation of the backflow device, the Backflow Department must be notified to inspect the installation to insure that the device meets the District specifications. It will then be tested by District personnel.
- 8) There will be no charge if the backflow device is installed correctly and test properly on the first inspection. If the backflow device fails the first test, it shall be the responsibility of the property owner to have any necessary repairs made. Repairs must be made according to District specifications. Any additional inspections will be charged one hundred twenty eight dollars (\$128) plus the costs of parts if needed.
- 9) Backflow / RP device charges will be adjusted annually based on the ENR (Engineering News Record) Construction Cost Index (CCI) of February. Staff will report back to the Board of Directors no less than every five (5) years with analysis comparing fees to actual costs.
- 10) Any damages or leaks after the customer shut-off valve will be the property owner's responsibility.

Sec. ~~19~~ 10.22.5 Well Destruction and Alteration.

To protect the State's groundwater supplies, the Legislature authorized the establishment of standards (Department of Water Resources Bulletins 74-81 and 74-90) and regulations pertaining to the construction, alteration, and destruction of wells.

California Water Code Section 13750.5 requires that those responsible for the construction, alteration, or destruction of water wells, cathodic protection wells, groundwater monitoring wells, or geothermal heat exchange wells possess a C-57 Water Well Contractor's License. This license is issued by the Contractors State License Board.

California Water Code Section 13751 requires that anyone who constructs, alters, or destroys a water well, cathodic protection well, groundwater monitoring well, or geothermal heat exchange well file with the Department of Water Resources a report of completion within sixty (60) days of the completion of the work.

The Land and Water Quality Division regulates the design, construction, modification, and destruction of water wells throughout San Diego County to protect San Diego County's

groundwater resource. Water Wells are commonly used as the only potable water supply in the rural areas of San Diego County. For general information call the San Marcos office at (760) 471-0730.

Upon the completion of the well destruction or alteration, the property owner is responsible for supplying proper documentation to the District.

If the property owner chooses not to follow the California Water Code (listed above) within sixty (60) days, the District shall have the right to discontinue water service and charge a fee of fifty dollars (\$50) to lock the meter. A fee of one hundred (\$100) will be charged for broken or damaged locks. Damage to corp or angle stop in attempt to restore services will be billed at actual time and material and added to the water bill. The water service will be restored only after the fees are paid and a Reduced Pressure Backflow Device is installed (See Section ~~19~~10.22.3&4) and passes and meets the District standards.

Sec. ~~19~~ 10.23 Booster Pumps.

No person shall place or cause to be placed a device to raise the pressure of water supplied him by the District unless said booster system plans and proposals have been submitted to the District's General Manager and written approval for its installation and use has been secured. In the event such apparatus is installed without permission, the General Manager will immediately discontinue service to the consumer and resume service only after satisfactory removal or correction and payment of turn-on charges and payment for any repair or treatment necessary for sanitary and safe operation.

Sec. ~~19~~ 10.23.1 Fallbrook Service Area Pressure Zones. Any approved individual service booster pump in the following pressure zones will be installed, operated, and maintained entirely at the individual customer's expense and will remain the property of the individual customer:

- 1) Toyon Heights
- 2) Sachse
- 3) Red Mountain
- 4) Gheen
- 5) Modified Town
- 6) Rattlesnake

Sec. ~~19~~ 10.23.2 DeLuz Heights Service Area Pressure Zones. Any approved individual service booster pump in the DeLuz Service Area will be installed, operated, and maintained entirely at the individual customer's expense and will remain the property of the individual customer, with the exception of the following meter numbers:

- 1) Meter No. 7783
- 2) Meter No. 7784
- 3) Meter No. 7789

Sec. ~~19~~ 10.24 Fire Hydrants.

For installing, maintaining and use of fire hydrants, the following will apply:

The District will install fire hydrants and necessary piping so required where and when jointly approved by the District staff and the Chief of the Fire District at the cost of the North County Fire Protection District.

In the event hydrants are required as part of pipeline extensions to service a subdivision or consumer, the cost of such hydrants will be included in the cost of the extension construction and paid for by the subdivider or consumer. Charges for installation of hydrants on the existing District distribution system will be as follows:

Model J-3700 (2-port hydrant).....	\$9,138	(complete assembly)
Model J-3765 (3-port hydrant).....	\$9,896	(complete assembly)
Fire flow testing .....	\$532	

If paving over 20 feet is required, there is an additional fee of \$257 per trench foot. If county road inspection is required, there is an additional fee of \$1,402.

Charges for fire hydrants will be adjusted annually based on the ENR (Engineering News Record) Construction Cost Index (CCI) of February. Staff will report back to the Board of Directors no less than every five (5) years with analysis comparing fees to actual costs. Maintenance and repairs to hydrants, valves and connecting pipelines, will be performed by the District at the expense of the North County Fire Protection District.

Sec. ~~19~~ 10.25                    Automatic Sprinkler and Fire Protection Systems.

For automatic sprinkler and fire protection systems, the District upon request, will install a detector check valve system subject to the payment of the following installation charges by the user:

4 inch service .....	Cost
6 inch service .....	Cost
8 inch service .....	Cost

Sec. ~~19~~ 10.26                    Construction Meters.

For each use of a fire hydrant by any person not officially associated with a fire fighting organization, by pre-arrangement and approval of the District, and upon receipt of a \$1,266 deposit, a meter installation charge of \$123 will be made. There will be a relocation charge of \$123 to cover cost of moving a construction meter. Upon notification by customer that the construction meter is no longer needed, District staff will retrieve the meter. Charges for construction meters will be adjusted annually based on the ENR (Engineering News Record) Construction Cost Index (CCI) of February. Staff will report back to the Board of Directors no less than every five (5) years with analysis comparing fees to actual costs. Upon retrieval, deposits will be refunded to the customer less any accrued operations charges and water use charges. The cost to repair a damaged construction meter will be deducted from the deposit. The construction meter will be locked to the fire hydrant and moved only by District staff. If the meter is stolen, the District will bear the cost of replacement.

Sec. ~~19~~ 10.27                    Water Used for Annual Crops.

For each use of water for agricultural purposes solely for the growing of annual crops, as described in Sec. ~~19~~ 10.1, Temporary Ag Service, the connection charge levied by Sec. ~~19~~ 10.8 will not be assessed for this purpose.

All other fees, assessments, and charges of this Administrative Code will be in effect. The Board of Directors will determine annually the availability of water for these purposes, and the use will be continued on a year to year basis at the discretion of the Board of Directors.

Sec. ~~19~~ 10.28            Illegal Use of Water.

The District may discontinue service to any consumer who uses or permits the use of District water beyond District boundaries or who within the District permits the flow of water beyond the limits of his property which is recorded as being served by the meter service through which the water is supplied. After discontinuing service for such cause, a charge of \$100 plus the estimated cost of the water so wasted or misused will be made and water service will not be resumed until paid.

Sec. ~~19~~ 10.29            Water Service Outside District.

In the event that the District should at any time have surplus water over and above that which may be needed and used within the limits of the District, then and in that event, the Directors of the District are hereby authorized to enter into a contract for the sale of such surplus water outside the boundaries of the District, upon such terms and conditions and for such rates as the Directors may at the time deem for the best interests of said District, provided, however, that in no case shall the Directors of said District, in fixing the rate to be charged for water in such contract, charge less than a sum which would represent the cost of actually developing and delivering said water outside of said boundaries of said District.

Sec. ~~19~~ 10.30            Application of Water Service to Affordable Housing

Per Government Code Sec. 65589.7, effective July 1, 2006, the District shall not deny or condition the approval of an application for water service to, or reduce the amount of services applied for by, a proposed development that includes housing units affordable to lower income households unless the District makes specific written findings that the denial, condition, or reduction is necessary due to the existence of one or more of the following:

- a) The District does not have sufficient water supply as defined in paragraph (2) of subdivision (a) of Government Code Sec. 66473.7 or is operating under a water shortage emergency as defined in Water Code Sec. 350, or does not have sufficient water treatment or distribution capacity to serve the needs of the proposed affordable housing development as demonstrated by a written engineering analysis and report; or
- b) The District is subject to a compliance order issued by the State Department of Health Services that prohibits new water connections; or
- c) The District does not have sufficient sewer treatment or collection capacity to serve the needs of the proposed affordable housing development as demonstrated by a written engineering analysis and report; or
- d) The District is under an order issued by the Regional Water Quality Control Board that prohibits new sewer connections; or

- e) The applicant fails to agree to reasonable terms and conditions for water service from the District which is generally applicable to other development projects seeking water service from the District including, but not limited to, payment of any fee or charge authorized by Government Code §66013.

Sec. ~~19~~ 10.30.1      Review of Service Policies.

At least once every five (5) years after passage of this policy, the policies contained in this section shall be presented to the Board of Directors of the District for a review and evaluation of the written policies governing water service to proposed developments that include housing units affordable to lower income households.

Sec. ~~19~~ 10.31      Administrative Fees.

The following administrative fees will be charged for the preparation, processing, and recording of the following documents:

Insufficient Funds Check	\$25
Temporary Service Agreements	\$50
Remote Meter Agreements	\$50
Quitclaim of Easement	\$50
Grant of Easement	\$50
Grant Deed	\$50
Temporary Sewer Service Agreements	\$50
Repayment Agreements	\$100

<b>ARTICLE 19</b> ( <u>Renumbered as Article 10 by Resolution 5006</u> )
Sec. 19.1,19.4,19.6, 19.21, 19.23 & 19.28 – Rev. 6/93
Sec. 19.5, 19.21 & 19.24 – Rev. 2/94
Sec. 19.8 – Rev. 4/95
Sec. 19.1 – Rev. 8/95
Sec. 19.33-19.43 – Rev. 8/95
Sec. 19.5, 19.24-19.25 – Rev. 9/96
Sec. 19.6-19.8 – Rev. 9/96
Sec. 19.23 – Rev. 10/96
Sec. 19.8 – Rev. 6/97
Sec. 19.1 – Rev. 7/97
Sec. 19.11 – Rev. 7/98
Sec. 19.9 – Deleted (all parcels paid) – Rev. 9/98
Sec. 19.21 – Rev. 6/99
Sec. 19.8 – Rev. 7/99
Sec. 19.9 – Rev. 11/99
Sec. 19.20.2 – Rev. 11/99
Sec. 19.9.2 – Rev. 7/00
Sec. 19.8 – Rev. 12/00
Sec. 19.8 – Rev. 8/01



**ARTICLE 19 CONTINUED**

(Renumbered as Article 10 by Resolution 5006)

- Sec. 19.21, 19.23 – Rev. 07/03
- Sec. 19.6, 19.21 – Rev. 6/04
- Sec. 19.8, Rev. 1/05
- Sec. 19.5 – Rev. 7/05
- Sec. 19.4 & 19.8 – Rev. 3/06
- Sec. 19.5, 19.6, 19.19, & 19.21 – Rev. 6/06
- New sec. 19.27 added 6/06
- Sec. 19.5, 19.8 & 19.23 – Rev. 12/06
- New Sec. 19.4 – Added 2//07
- Sec. 19.20 – Rev. 3/07
- Sec. 19.22 – Rev. 6/07
- Sec. 19.6 – Rev. 6/07; 19.7 – Added 6/07; 19.20 – Rev. 6/07; 19.22 – Rev. 6/07
- New 19.11 – added 8/07
- Sec. 19.1 (last para pg. 1) & 1<sup>st</sup> para. Pg. 2 – Rev. 12/07
- Sec. 19.8.2 – Add 3/08
- Sec. 19.1, 19.6, 19.7, 19.8, 19.8.1, 19.9, 19.14, 19.22, 19.24, 19.26, 19.27, and 19.31 – Rev. 6/08
- Sec. 19.1, 19.6, 19.8, 19.8.2, 19.10, 19.11.2, 19.11.3, 19.11.4, 19.11.5, 19.11.6, 19.22, 19.24, - Rev. 6/09
- 19.1, 19.5 Rev. 8/09
- Sec. 19.22-19.22.5 – Rev. 10/09
- Sec. 19.8.1 – Rev. 5/10
- Sec. 19.5 – Rev. 10/10
- Sec. 19.3 – Rev 12/10
- Sec. 19.6, 19.7, 19.8.2, 19.22.2, 19.24, 19.26 – Rev. 5/11
- Sec. 19.8, 19.9 – Rev. 4/12
- Sec. 19.1, 19.5, 19.6, 19.7, 19.8, 19.8.2, 19.22.2, 19.24, 19.26 – Rev. 6/12
- Sec. 19.5, 19.6, 19.7, 19.8, 19.8.2, 19.22.2, 19.24, 19.26 – Rev. 6/13
- Sec. 19.1, 19.5, 19.6, 19.7, 19.8, 19.8.2, 19.10, 19.22.2, 19.24, 19.26 – Rev. 6/14
- Sec. 19.8.1 – Rev. 10/14
- Sec. 19.6, 19.7, 19.8, 19.8.2, 19.22.2, 19.24, 19.26 Rev. 6/15
- Secs. 19.1, 19.5, 19.11, 19.11.1, 19.11.2, 19.11.3, 19.11.4, 19.11.5, 19.11.6, 19.22.1 Rev. 3/16
- 19.4.2 (add), 19.6, 19.7, 19.8, 19.8.2, 19.10, 19.22.2, 19.24, 19.26 – Rev. 7/16

**ARTICLE 19 CONTINUED**

(Renumbered as Article 10 by Resolution 5006)

- Sec. 19.10 - Rev. 1/17
- Secs. 19.4.2, 19.6, 19.7, 19.8, 19.8.2, 19.10, 19.22.2, 19.22.4, 19.24, 19.26 – Rev. 12/18
- Secs. 19.12.1, 19.12.2, 19.24 – Rev. 7/19
- Secs. 19.4.2, 19.6, 19.7, 19.8, 19.8.2, 19.10, 19.22.2, 19.24, 19.26 – Rev. 12/19
- Secs. 19.1, 19.5, 19.11, 19.11.1, 19.11.2, 19.11.3, 19.11.4, 19.11.5, 19.11.6 – Rev. 12/20
- Secs. 19.4.2, 19.6, 19.7, 19.8, 19.8.2, 19.10, 19.22.2, 19.22.4, 19.24, 19.26 – Rev. 12/20

**Article ~~20~~11. Sewer Service Requirements and Fees**

**Sec ~~20~~11.1 Definitions.**

For the purpose of this Administrative Code and the regulation of sewer service by the Fallbrook Public Utility District, the following definitions are adopted:

The word “applicant,” as used herein, shall mean a person making application to the District for a permit for a sewer connection, Special Use Permit, determination or redetermination.

The term “application,” as used herein, shall mean the application form approved by the District for applicants to submit a request for sewer service to the District or for a Special Use Permit, or determination or redetermination of equivalent dwelling units.

The term “Authorized Inspector,” as used herein, shall mean the person designated by the General Manager to conduct inspections and take enforcement actions for the purpose of ensuring compliance with this chapter.

The term “Board,” as used herein, shall mean the governing board of the Fallbrook Public Utility District or any successor-in-interest.

The term “BOD,” as used herein, means biochemical oxygen demand.

The term “bypass” means the diversion of waste streams from any portion of the sewer system.

The term “discharge” means the addition of any material to the District’s sewer system.

The term “District,” as used herein, shall mean the Fallbrook Public Utility District or any successor-in-interest or any person authorized by the Board or General Manager to act as a representative of the District.

The term “Domestic Sewage” shall mean the liquid and water-borne wastes derived from humans in dwelling units and non-industrial commercial structures or uses, said wastes being of such character as to permit satisfactory disposal into a public sewer or private disposal system without special treatment.

The term “Equivalent Dwelling Unit” or “EDU,” as used herein, shall mean an increment of wastewater flow attributable to a single-family residence and as further discussed in Section ~~20~~11.7.

The term “Industrial User” refers to a person whose discharges or processes have a different characteristic than domestic sewage or domestic activities and which may require special review or a Special Use Permit in accordance with this Article.

The term “Owner,” as used herein, shall mean the holder of record title to a parcel or parcels of real property located within the District.

The term “Parcel Map,” as used herein, shall mean the division of a parcel of land into four (4) or fewer lots in compliance with the Subdivision Map Act.

The term “Parcel of Land,” as used herein, shall mean a separate parcel of land recognized as a separate unit by the Assessor’s office for the County of San Diego and legally subdivided by California law.

The term “pass through” means wastewater leaving the District’s sewer system in quantities or concentrations which, alone or in conjunction with a discharge or discharges from other sources, is a cause of a violation of any requirement of the state or federal law, regulation, or order.

The term “Permit,” when used as a noun as used herein, shall mean permit for a sewer connection required by the District for any discharger to the District’s sewer system and includes a sewer permit, a Special Use Permit, a temporary sewer service agreement, and any other authorization to connect to and use the District’s sewer system.

The term “person,” as used herein, shall mean any individual, entity, partnership, firm, association, corporation or public agency, including the State of California and the United States of America.

The term “Project,” as used herein, shall mean the development, use, building or structure for which the owner is seeking sewer service and all developments, uses, buildings, and structures which have not previously secured a sewer permit from the District.

The term “sewer system” or “District’s sewer system” shall mean all of the publicly owned property involved in the operation of the sewage collection, treatment, and disposal system in the District, including land, sewers and appurtenances, pumping stations, and the treatment works and equipment.

The term “Special Use Permit” shall mean a permit for a sewer connection issued by the District to certain industrial users of the District’s sewer system in accordance with Section [2011.9](#).

The Term “SS,” as used herein, means suspended solids.

The term “Subdivision,” as used herein, shall mean any improved or unimproved real property, or a portion thereof, shown on the latest equalized County Assessment Tax Roll as a unit or as contiguous units which is divided into five (5) or more parcels for the purpose of sale, lease or financing.

The term “upset” means an incident in which there is temporary noncompliance with requirements of the District’s sewer system regulations.

The term “user” refers to any person who connects to or discharges to or authorizes, permits, facilitates, or allows the connection or discharge to the District’s sewer system.

Sec ~~20~~ 11.2 Prohibited Connections.

It shall be unlawful for any person to connect to or to facilitate, authorize, permit, or allow connection to the District sewer system or to add or to facilitate, authorize, permit, or allow the addition of any building, apartment, trailer, or other unit to an existing sewer connection or commence construction of any sewer line within the District without having first obtained a written permit from the District authorizing such connection or construction in accordance with Division 20.2 of this Article. No permit to connect shall be issued except to the owner of the property or the owner’s duly authorized agent.

Sec ~~20~~ 11.3 Prohibited Uses and Prohibited Discharges.

It is unlawful for any person to use or discharge to, or to facilitate, authorize, permit, or allow the use of or discharge to, the sewer system except in accordance with Division 20.3.

Industrial users subject to the pretreatment standards specified in Part 403 of Title 40 of the Code of Federal Regulations are prohibited from connecting to or discharging into the District’s sewer system.

Sec ~~20~~ 11.4 Permit Required.

No person or entity shall be entitled to establish, authorize, cause, facilitate or allow a connection or discharge to the District’s sewer system without first obtaining a sewer permit in accordance with Section ~~20~~ 11.4, a Special Use Permit in accordance with Section ~~20~~ 11.9 or a temporary sewer service agreement in accordance with Section ~~20~~ 11.10 and paying required fees in accordance with this Article.

No person or entity shall be entitled to discharge or to authorize, cause, facilitate, or allow a discharge to the District’s sewer system except as authorized by a sewer permit, Special Use Permit or temporary sewer service agreement. Permits are issued only for the use expressly authorized by the permit.

If a permit does not show thereon the number of equivalent dwelling units for which it is issued, the holder of the permit may seek a determination of the equivalent dwelling units authorized by the permit in accordance with this Article.

The holder of a permit who seeks to undertake any of the following actions on the property associated with the permit must submit an application for a redetermination of equivalent dwelling units as set forth in Section ~~20~~ 11.7 and/or a redetermination of strength classification under Section ~~20~~ 11.8 and, if required apply for a new or amended permit and pay fees in accordance with this Article:

- a) add a new or change an existing use of a property;

- b) remodel, renovate, or enlarge a structure that discharges or connects to the District's sewer system;
- c) construct any additional improvements on the parcel of property that discharges or connects to the District's sewer system;
- d) discharge a greater volume of wastewater than is authorized by an existing sewer permit;
- e) discharge wastewater with a greater concentration of BOD, SS or other constituent than is authorized by the sewer permit.

No sewer permit required by this Section is valid until the applicant has paid all fees and charges of the District and complied with all requirements of this Administrative Code. An applicant does not have any right to sewer service until the permit is issued. Upon issuance of the permit, monthly service charges will commence in accordance with this Article.

Sec 2011.5 Sewer Permit Application Process.

Sec 2011.5.1 Submission of Application.

Any person required to obtain a permit in accordance with Section 2011.4 must submit a request for sewer service from the District on the application form approved by the District. The application shall be made in the name of the Owner and be signed by the Owner or Owner's authorized representative. No application shall be deemed complete for the purposes of processing until the District has obtained all information requested by District staff to process the application, which may include but is not limited to the following:

- a) Environmental Review.

Upon request, the applicant shall provide the District with all documents evidencing any environmental review of the project for which the applicant seeks sewer service. If the District determines that additional environmental review is necessary, the applicant shall be required to complete this additional environmental review. All environmental review shall be at the applicant's sole cost and expense. The District may elect to utilize the applicant's environmental expert or may elect to retain its own environmental consultant at the applicant's sole cost and expense. Where District staff determines that the environmental review is insufficient, the District may require a deposit for additional environmental review as determined necessary by District staff. All costs for such additional environmental review shall be paid by the applicant.

- b) Plans and Specifications.

Except where waived by District staff, all applications for a sewer permit shall be accompanied by a complete set of all plans and specifications for the proposed development prepared by an architect or engineer licensed in the State of California. The District shall have no obligation to process any application until District staff has received

all plans and specifications determined necessary by District staff to consider the impacts of the proposed project on the District's sewer system.

c) Parcel Maps and Subdivisions.

Applications for sewer service to parcel maps and subdivisions will not be processed until the applicant submits an executed application form and the District has been provided with a copy of the parcel map or subdivision map prepared by a licensed civil engineer in the State of California. The parcel map or subdivision map shall show all proposed sewer facilities. Where the parcel map or subdivision will require a pipeline extension, the applicant will be required to execute a pipeline extension agreement.

Sec 2011.5.2 Determination of Equivalent Dwelling Unit and Strength.

Upon receiving an application for issuance of a sewer permit, the District will determine the number of equivalent dwelling units and anticipated strength classification for which the Permit shall be issued, and fees shall be calculated in accordance with this Article.

Sec 2011.5.3 Payment of Fees.

Before a sewer permit may be issued, the applicant must pay the following fees or arrange for payment of the fees pursuant to Section 2011.16:

- a) Capacity fees in accordance with Section 2011.16.2;
- b) Plan Check fees in accordance with Section 2011.16.3;
- c) Lateral fees in accordance with section 2011.16.4, if applicable;
- d) Fees to inspect contractor-installed laterals in accordance with Section 2011.16.5, if applicable; and
- e) Annexation fee in accordance with Section 2011.16.6, if applicable.

Sec 2011.6. Sewer Availability Forms and Letters.

If an applicant has submitted a completed application, all environmental review has been completed to the satisfaction of the District, and the District has reviewed and approved the applicant's plans for sewer service, and all fees have been paid or guaranteed, the District may issue a sewer availability letter or execute the Sewer Project Facility Availability form provided by the County of San Diego.

Execution of the sewer availability letter or form is not a commitment that the District will provide sewer service to any project nor is it a guarantee that sewer service will be available to serve the project at the time a sewer commitment is actually made. Execution of the sewer availability letters or forms merely indicates that sewer service is available at the time the District executes the sewer availability letter or form. The District is not committed to provide sewer service until the District issues the permit, the applicant pays

all deposits and fees required by the District, and all sewer facilities required to serve the project by the District have been completed and accepted by the District.

Sec ~~2011~~.7 Equivalent Dwelling Units.

a) Equivalent Dwelling Unit Schedules.

1. The following schedule shall be used when determining the equivalent dwelling units and class of service for any connection to the District’s sewer system.

(SEE SCHEDULE OF EQUIVALENT DWELLING UNITS AND CLASS OF SERVICE ON THE FOLLOWING PAGES)

SCHEDULE OF EQUIVALENT DWELLING UNITS AND CLASS OF SERVICE

Equivalent Class	Description	Dwelling Units
Class 1	Single Family Residence	
	Single family residence	1.00
	Mobile home on individual parcel	1.00
Class 2	Apartment/Condominium/Attached Cottage-Mobile Home	
	Per detached cottage with bathroom and kitchen on a parcel with a single family residence	0.80
	Per mobile home on a parcel with a single family residence	0.80
	Per apartment unit	0.80
	Per condominium/duplex unit	0.80
	Accessory Dwelling Unit* (As defined by State Government Code.)  *Capacity Fees do not apply to Accessory Dwelling Units (ADUs) that are exempt from such fees under State Law. Sewer Service Fees still apply, and they are determined by the applicable EDU factor.	0.40
Class 3	Mobile Home Park	
	Per separate mobile home space	0.80
	Motel/Hotel with no restaurant	
Class 4	Per motel/hotel with kitchen unit	0.80
Class 41	Per motel/hotel without kitchen unit	0.50
	A Separate Business, Retail Shop With Office, Or Packing House Equipped With Restroom Facilities, Or Not So Equipped But Located In A Building Or Complex With Common Restroom	
Class 5	First 3500 square feet (exterior building area) facilities	1.33



Class 55	Per additional 1000 square feet (exterior building area)	0.38
	Automotive Service Station	
Class 6	4 pumps or less	2.00
Class 61	More than 4 pumps	3.00
Class 62	Per recreational vehicle holding tank disposal station	1.00
	Church, Fraternal Lodge Or Similar Auditorium	
Class 7	Per 200 seating capacity	1.00
	Bakery	
Class 8	Per 3500 square feet (exterior building area)	1.00
	Theater	
Class 9	Per 150 seating capacity	1.33
	Hospital	
Class 10	Per bed	0.65
	Convalescent or Boarding Home	
Class 11	Per bed	0.30
	Elementary School / Daycare	
Class 13	Per 60 Students	1.00
	Junior High School	
	Per 40 Students	1.00
	High School	
Class 17	Per 30 Students	1.00
	Mortuary	
Class 14		1.00
	Car Wash with water recovery system and public restroom	
Class 21		2.00
	Self Service Laundry	
Class 23	Restaurants	2.00
	Restaurant Under 2500 Square feet	
Class 24		3.00
	Restaurant 2501-7000 Square feet	
Class 25		4.00
	Restaurant Over 7000 Square feet	
Class 26		5.00

	Grocery Stores	
Class 32	Grocery Stores Under 2500 feet	3.00
Class 33	Grocery Stores 2501-7000 Square feet	4.00
Class 34	Grocery Stores Over 7000 Square feet	5.00
Class 88	Standby	0.24

2. Unclassified Users. Users whose use is not classified in the above table are considered “unclassified users.” District staff shall determine the number of equivalent dwelling units for which a permit shall be issued to an unclassified user, including but not limited to commercial and industrial users, based upon the estimated volume of wastewater to be discharged therefrom into the District’s sewer system. An unclassified user that is also an Industrial User may be required to obtain a Special Use Permit pursuant to Section 2.9.

b) Determination and Redetermination of Equivalent Dwelling Units.

1. Determination of Equivalent Dwelling Units.

The holder of an existing sewer permit which does not show thereon the number of equivalent dwelling units for which it is issued, may make application to the District for a determination of equivalent dwelling units based on the current use of the property to which the permit relates.

Upon receipt of an application, the District shall determine the number of equivalent dwelling units which shall be credited to the permit based on this section.

Upon completing the determination of the number of equivalent dwelling units to be assigned to an existing permit, the District shall amend the permit to show thereon the number of equivalent dwelling units assigned thereto and shall also make a notation of such equivalent dwelling units assigned to the existing in the appropriate District record.

2. Redetermination of Equivalent Dwelling Units.

Upon receiving an application for a redetermination, the District shall determine the number of equivalent dwelling units assigned to such permit and the number of equivalent dwelling units required by the action undertaken by the permit holder. If the permit does not accurately show the number of equivalent dwelling units for which it was issued or which will exist after the action undertaken by the permit holder, the District shall determine the number of equivalent dwelling units to be assigned to such permit in the manner above provided in this section, and whether the action undertaken by the permit holder will necessitate additional equivalent dwelling units.

If additional equivalent dwelling units are required as a result of the action undertaken by the permit holder, the applicant will be required to acquire additional equivalent dwelling units in accordance with Section ~~2011~~.4, to construct any additional sewer facilities determined necessary by the District to adequately serve the property, and to pay fees required by this Article based on the fees in effect at the time the application is submitted for the additional number of equivalent dwelling units calculated by District staff.

3. Reduction in Equivalent Dwelling Units.

If any determination or redetermination conducted in accordance with this Section results in a reduction in equivalent dwelling units, such reduction in capacity will reduce the ongoing capital improvement charge, but will not result in any refund of capacity fees.

Sec ~~2011~~.8 Determination and Classification of Strength (BOD and SS).

The District shall use the following guidance when determining the anticipated concentrations of BOD and SS for discharges to the District's sewer system:

- a) Low strength: BOD < 200 mg/l and SS < 200 mg/l: Retail, laundry, church or community facility with no kitchen, offices, car wash, nursing home or hospital.
- b) Medium strength: BOD 200 - 700 or SS > 200 -700: hotel, auto service station, hotel with restaurant, light manufacturing.
- c) High strength: BOD > 700 mg/l or SS > 700 mg/l: Restaurant, mortuary, manufacturing or high strength wastes.

The allowable discharge strength classification shall be set forth in the permit.

Industrial Users required to obtain a Special Use Permit may be subject to alternative strength classification requirements and/or additional discharge requirements pursuant to Section ~~2011~~.9.

Any user or applicant whose actual or proposed discharge is determined by the District to have characteristics that may adversely impact sewer system operations or the District's ability to comply with state and federal laws, regulations, or orders must immediately cease any actual discharge and obtain and implement a Special Use Permit in accordance with Section ~~2011~~.9 before commencing or recommencing any such discharge.

Sec. ~~2011~~.9 Special Use Permits.

Any user or applicant whose actual or proposed discharge is determined by the District to have characteristics that may adversely impact sewer system operations or the District's ability to comply with state and federal laws, regulations, or orders must immediately cease

any actual discharge and obtain and implement a Special Use Permit before commencing or recommencing any such discharge.

Applicants for Special Use Permits shall complete and file the standard application form and submit all applicable fees. Applications for a Special Use Permit shall include such additional information as may be required by the General Manager, which may include, but not be limited to, sewage constituents and characteristics (as may be determined by a laboratory approved by the District), and any other information deemed necessary by the District to evaluate the application.

The Special Use Permit shall be subject to all requirements and provisions applicable to general permits under this Article, but may also be subject to one or more of the following:

- a) Limitation of the volume discharged;
- b) Restriction of peak flow discharges;
- c) Pretreatment of wastewater prior to discharge;
- d) Discharge of certain wastewater only to specified sewers of the District;
- e) Relocation of the point of discharge;
- f) Prohibition or limitation of discharge of certain wastewater constituents;
- g) Restriction of discharge to certain hours of the day;
- h) Filing of periodic self-monitoring discharge reports or results of periodic measurements;
- i) Installation of a suitable manhole together with such necessary meters and other appurtenances to facilitate observation, sampling, and measurement of the wastes;
- j) Payment of additional charges to defray increased costs of the District created by the wastewater discharge; and
- k) Such other conditions as may be required to achieve the purpose of this section.

Sec 2011.10 Temporary Sewer Service Agreement.

A Temporary Sewer Service Agreement is a recorded agreement between the District and a user that a sewer will be placed temporarily at a location remote from the property to be served, where the District intends, at some future date, to extend the District sewer system to abut the property described in the agreement, and that the consumer is responsible for extending a temporary private line from the sewer to the property to be served, and obtaining whatever temporary easements are required for such extension. Temporary sewer service agreements shall establish the financial obligations of the user related to the

future installation costs of the District's distribution system and the cost of relocation of the sewer, and shall be binding upon the signatory and all successor owners of said property.

If the user's obligation is to be secured with a promissory note and deed of trust, the terms will be based on the 10-year Treasury Bill rate plus 2%. Interest will be recalculated annually on the anniversary date of the recorded Trust Deed and will be compounded annually on the same anniversary date.

Sec. ~~2011~~.11 Permit Modifications.

The terms and conditions of a permit may be subject to modification by the District, in accordance with any changes in the effluent standards limitations or prohibited substances by superior regulators or in response to violations of this Code. The discharger shall be informed of any proposed changes in the permit at least thirty (30) days prior to the effective date of change, except in the case of violations of a permit or other order of the District, which may be modified as needed to protect public health, safety, and welfare, the District's sewer system, or personnel. Any modifications or new conditions in the permit shall include a reasonable time schedule for compliance.

No person shall discharge sewage in excess of the quantity or quality limitations set by a permit. Anyone desiring to discharge wastes or use wastewater facilities that are not in conformance with terms of a permit must apply to the District for an amendment to the permit or for a Special Use Permit, as applicable.

Sec. ~~2011~~.12 Permits Non-Transferable.

A permit issued for a particular parcel of land is specifically limited to use for that parcel of land. A permit shall not be transferred to or used for a parcel of land which is not specifically described in the permit. Permits may be used only for the use which is specifically set forth on the permit.

Sec. ~~2011~~.13 Application of Sewer Service to Affordable Housing.

Per Government Code Sec. 65589.7, effective July 1, 2006, the District shall not deny or condition the approval of an application for sewer service to, or reduce the amount of services applied for by, a proposed development that includes housing units affordable to lower income households unless the District makes specific written findings that the denial, condition, or reduction is necessary due to the existence of one or more of the following:

- a) The District does not have sufficient water supply as defined in paragraph (2) of subdivision (a) of Government Code Sec. 66473.7 or is operating under a water shortage emergency as defined in Water Code Sec. 350, or does not have sufficient water treatment or distribution capacity to serve the needs of the proposed affordable housing development as demonstrated by a written engineering analysis and report; or

- b) The District is subject to a compliance order issued by the State Water Resources Control Board, Division of Drinking Water that prohibits new water connections; or
- c) The District does not have sufficient sewer treatment or collection capacity to serve the needs of the proposed affordable housing development as demonstrated by a written engineering analysis and report; or
- d) The District is under an order issued by the Regional Water Quality Control Board that prohibits new sewer connections; or
- e) The applicant fails to agree to reasonable terms and conditions for sewer service from the District which is generally applicable to other development projects seeking sewer service from the District including, but not limited to, payment of any fee or charge authorized by Government Code §66013.

Sec. ~~2011~~.14 Sewer Use Requirements.

Sec. ~~2011~~.14.1 General Conditions for Sewage Disposal.

No person shall discharge to the District's sewer system except through a connection permitted in accordance with Division 20.2 and in accordance with the sewer use requirements of this Division 20.3 and on payment of fees and charges provided in Division 20.4. Unless specifically authorized in a Special Use Permit issued by the District, no person shall discharge to the District's sewer system anything other than domestic sewage that complies with the requirements of this Article.

No person shall discharge to the District' sewer collection system in any manner that does the following:

- a) Create nuisances such as odors,
- b) Menace or endanger public health or safety or damage public or private structures, facilities or improvements,
- c) Impose unreasonable collection, treatment, or disposal costs to the District,
- d) Interfere with wastewater treatment processes,
- e) Exceed quality requirements set by regulatory government agencies,
- f) Detrimentially affect the local environment,
- g) Causes or contributes or threatens to cause or contribute to a bypass of untreated waste, pass through, or upset; or
- h) Cause or contribute to a violation of any permits applicable to the District's sewer system or treatment facilities.

Sec. ~~2011~~.14.2 Discharge Prohibition.

Unless written approval has been provided by the District, no person shall discharge or cause to be discharged into the District's sewer, directly or indirectly, the following:

- a) Any storm water, surface water, groundwater, roof runoff, subsurface drainage, uncontaminated cooling water, or industrial process waters.
- b) Pollutants which create a fire or explosion hazard, including but not limited to any gasoline, benzene, naphtha, fuel oil, or other flammable or explosive liquid, solid, or gas.
- c) Any waters or wastes containing toxic or poisonous solids, liquids, or gases in sufficient quantity, either singly or by interaction with other wastes, to injure or interfere with any sewage treatment process, constitute a hazard to humans or animals, create a public nuisance, or create any hazard in the receiving waters of the sewage treatment plant, including but not limited to cyanides in excess of two (2) mg/L as CN in the wastes as discharged to the public sewer.
- d) Pollutants which will cause corrosive structural damage to the sewer system, but in no case any waters or wastes having a pH lower than 6.0 or in excess of 9.0, or having any other corrosive property capable of causing damage or hazard to structures, equipment, and personnel of the sewage works.
- e) Solid or viscous substances in quantities or of such size capable of causing obstruction to the flow in sewers, or other interference with the proper operation of the sewage works such as, but not limited to, cinders, sand, mud, straw, shavings, metal, glass, rags, feathers, tar, plastics, wood, ashes, unground garbage, whole blood, paunch manure, hair and fleshings, entrails and paper dishes, cups, milk containers, etc., either whole or ground by garbage grinders.
- f) Any pollutant, including oxygen demanding pollutants (BOD, etc.) released in a discharge at a flow rate and/or pollutant concentration which will cause interference with the sewer system.
- g) Brine from on-site regenerated ion exchange water treating devices.
- h) Water softener waste or any other salt water brine wastes.
- i) Any trucked or hauled pollutants, except at discharge points designated by the District.
- j) Fats, oils and grease (FOG) from food service establishments, except in compliance with the District's FOG program.
- k) Any other substances, materials, waters, or wastes if it appears likely in the opinion of the District's General Manager that such wastes can harm either the sewers, sewage treatment process, or equipment, have an adverse effect on the receiving

stream, or can otherwise endanger life, limb, public property, or constitute a nuisance. In making a determination as to the acceptability of these wastes, the General Manager will give consideration to such factors as the quantities of subject wastes in relation to flows and velocities in the sewers, materials of construction of the sewers, nature of the sewage treatment process, capacity of the sewage treatment plant, degree of treatability of wastes in the sewage treatment plant, and other pertinent factors. The substances prohibited are:

- l) Heat in amounts which will inhibit biological activity in the sewer system resulting in interference, but in no case any liquid or vapor having a temperature higher than one hundred fifty (150) °F (65°C).
- m) Any water or waste containing fats, wax, grease, or oils, whether emulsified or not, in excess of two hundred (200) mg/L or containing substances which may solidify or become viscous at temperatures between thirty two (32) and one hundred fifty (150) °F (0 and 65° C).
- n) Any garbage that has not been properly shredded. The installation and operation of any garbage grinder equipped with a motor of three fourths (3/4) horsepower (0.76 hp metric) or greater shall be subject to the review and approval of the District.
- o) Any waters or wastes containing strong acid iron picking wastes, or concentrated plating solutions whether neutralized or not.
- p) Any water or wastes containing boron, cadmium, chromium, copper, iron, lead, manganese, mercury, selenium, tin, zinc and similar objectionable or toxic substances, or wastes exerting an excessive chlorine requirement, to such degree that any such material received in the composite sewage at the sewage treatment works exceeds the limits established by the District for such materials. And, any water or wastes containing constituents in excess of those required by the District's current permits.
- q) Any water or wastes containing phenols or other taste odor producing substances, in such concentrations exceeding limits which may be established by the District as necessary, after treatment of the composite sewage, to meet the requirements of the State, Federal, or other public agencies of jurisdiction for such discharge to the receiving waters.
- r) Any radioactive wastes or isotopes of such half-life or concentration as may exceed limits established by the District in compliance with applicable State or Federal regulations.
- s) Materials which exert or cause:
  1. Any waters or wastes containing more than 350 parts per million by weight of suspended solids or have a 5 day B.O.D. greater than 300



parts per million by weight, or a C.O.D. greater than 600 parts per million by weight.

2. Excessive discoloration (such as, but not limited to, dye wastes and vegetable tanning solutions).
  3. Unusual B.O.D. chemical oxygen demand, or chlorine requirements in such quantities as to constitute a significant load on the sewage treatment works.
  4. Unusual volume of flow or concentration of wastes constituting “slugs” as defined herein.
- t) Waters or wastes containing substances which are not amenable to treatment or reduction by the sewage treatment processes employed, or are amenable to treatment only to such degree that the sewage treatment plant effluent cannot meet the requirements of other agencies having jurisdiction over discharge to the receiving waters.

Sec. 2011.14.3 FOG Compliance Program.

The District has prepared and adopted a fats, oils, and grease (FOG) program on the implementation and enforcement of this Article. The District may require compliance with the FOG program as a condition of a Special Use Permit under this Article. FOG program may be updated as needed to achieve the applicable performance standards for the sewer system.

Sec. 2011.15 Miscellaneous Provisions.

Sec. 2011.15.1 Provide Information.

Users must provide information regarding the nature of any discharge to the system on request of the District.

Sec. 2011.15.2 Users Outside the District.

The Board of Directors of the District shall have the power under Sec. 16474 of the Public Utilities Code to establish by agreement or resolution, the fees and charges and such other conditions as it deems appropriate that shall be imposed for providing sewer services to premises located outside the District. The provision of sewer services to premises outside the District shall also comply with applicable law, including but not limited to the Cortese-Knox-Hertzberg Local Government Reorganization Act of 2000 (Gov. Code § 56000 et seq.).

Sec. 2011.15.3 Agreements.

No statement contained in this Article shall be construed as preventing any special agreement or arrangement between the District and any discharger whereby waste

of unusual strength or character may be accepted by the District for treatment, subject to payment as agreed thereof by the discharger.

Sec. 2011.16 Fees and Charges.

Sec. 2011.16.1 Sewer Service Charges.

Every user of the District's sewer system must pay a sewer service charge for the use of the District's sewer system in an amount and at a frequency established by the Board.

Sec. 2011.16.2 Capacity Fees.

a) Capacity Fee Amount. Prior to issuance, reissuance, or amendment of a sewer permit the following capacity fees shall be paid by an applicant for a sewer permit for each equivalent dwelling unit determined by the District in accordance with Section 2011.7:

Capacity Fee	\$7,115 per EDU
--------------	-----------------

b) Adjustments to Capacity Fees. Capacity fee charges will be adjusted annually based on the ENR (Engineering News Record) Construction Cost Index (CCI) of February. Staff will report back to the Board of Directors no less than every five (5) years with analysis comparing fees to actual costs.

c) Financing Capacity Fees. Finance options are available for customers who owe additional fees to the District due to property expansions that did not purchase additional capacity and/or visual audits conducted by District staff as follows:

1. Any amounts financed by the District require a signed agreement and Promissory Note. Any amount greater than \$10,000 will also require a Trust Deed.
2. Any delinquent amounts will be transferred to the property tax bill.
3. Amounts up to \$3,000 are due immediately with no financing option.
4. Amounts between \$3,001 and \$5,000 may have terms of up to one year at the Local Agency Investment Fund (LAIF) rate + 2%.
5. Amounts between \$5,001 and \$10,000 may have terms of up to two years at the LAIF rate + 3%; interest to be re-calculated at the one year anniversary.
6. Amounts greater than \$10,001 may have terms up to three years at the LAIF rate + 4%; interest to be re-calculated at the one year and two year anniversaries.
7. Liens will not be offered as a methods of postponing payment of fees.

Sec. 2011.16.2 Plan Check Fees.

- a) An applicant must pay a plan check fee in accordance with the following:
1. Plan checks less than 500 lineal feet, water or sewer, \$500 each.
  2. Plan checks 500 lineal feet to 1,000 lineal feet, water or sewer, \$1,000 each.
  3. Plan checks greater than 1,000 lineal feet, \$1,000 each, plus .50 cents per lineal foot thereafter.

Sec. 2011.16.4 Lateral Fees.

If the District staff will be utilized to install a lateral from the main line and to put in a clean-out box and overflow device, the applicant shall pay the following fee upon submission of an application. The fee is to cover the cost to install a lateral from the main line and to install the clean-out box and overflow device, if a lateral is required based on the nature of the application:

Length	Depth	Crew Size	Hours	Cost
≤ 15'	≤ 8'	4	36	\$3,500
≤ 15'	>8'	4	56	\$5,422
>15' to 30'	≤8'	5	90	\$7,443
>15' to 30'	>8'	5	115	\$9,586
>30'	Any	5	Actual	Actual

If paving less than or equal to 15 feet is required, there is an additional fee of \$1,470. If paving is greater than 15 feet up to 30 feet is required, there is an additional fee of \$2,462. If county road inspection is required, there is an additional fee of \$1,402.

Lateral installation charges will be adjusted annually based on the ENR (Engineering News Record) Construction Cost Index (CCI) of February. Staff will report back to the Board of Directors no less than every five (5) years with analysis comparing fees to actual costs.

Sec 2011.16.5 Fees for District to Inspect Contractor-Installed Facilities.

If a contractor will install the sewer lateral and related facilities, the applicant shall pay a sewer lateral inspection fee on a time and materials basis. Upon submission of an application, the applicant shall pay a deposit for the estimated inspection fee, calculated as follows:

Sewer Lateral Installation      Estimated inspection hours @ \$106.31 = Estimated inspection fee

If the actual time per form inspection is less than the District's estimate, the District will refund the excess amount to the applicant. If the actual time to perform inspection exceeds the estimated time, the applicant shall pay the remaining amount due to the District as a condition of service. If the applicant fails to pay within the time specified by the District,

the District may include the remaining amount in its bill for for sewer service or seek collection through any other lawful means.

Inspection fees will be adjusted annually based on the Engineering News Record (ENR) Construction Cost Index (CCI) of February. Staff will report back to the Board no less than every five (5) years with analysis comparing current fees to calculated fees.

Sec. ~~2011~~.16.6 Annexation Fees.

An applicant must pay a sewer annexation fee for any connection located in an area that is required to be annexed to the sewer service area after March 23, 2012 in accordance with state law. Annexation fees are due with the other sewer permit fees when applying for a sewer permit and are calculated for each equivalent dwelling unit determined by the District in accordance with Section ~~2011~~.7.

Annexation Fee (if required)	\$11,389 per EDU
------------------------------	------------------

Sec. ~~2011~~.16.7 Fees and Charges May Be Collected with Taxes.

Notwithstanding any other provision of this Administrative Code, the fees and charges required by this Code, including the connection fee and the sewer service charges, or either of them may be collected on the tax roll in the same manner and together with the general taxes of the District pursuant to Section 16469 of the Public Utilities Code.

Sec. ~~2011~~.17 Right of Entry and Inspection.

To the fullest extent permitted by law, the officers, employees, and agents of the District shall have the right to enter upon any premises within the District to inspect and verify compliance with the Administrative Code or any permit, order, ordinance or authorization issued by the District. The District has the right to conduct routine inspections and sampling at any location where discharges to the sewer system occur.

Sec. ~~2011~~.18 Enforcement – Generally.

In addition to any remedies provided in this Code or available under any applicable law, the District may take any enforcement action or combination of enforcement actions provided in this Division against any person who violates any provision of this Article.

Sec. ~~2011~~.19 Administrative Enforcement.

Sec. ~~2011~~.19.1 Monitoring.

The Authorized Inspector may require any discharger who violates any provision of this Article or any permit, agreement, or other authorization issued in accordance with this Article to pay all costs associated with follow-up sampling, cost of analysis, and inspections needed to return the discharger to compliance. The discharger may be required

to install and maintain pre-treatment, monitoring, and sampling facilities to ensure compliance with this Code.

Sec. ~~2011~~.19.2 Citations.

The Authorized Inspector may issue an administrative citation directing a user or discharger to cease any action that violates any provision of this Article or any permit, agreement, or other authorization issued in accordance with this Article and may require the user or discharger to take any action necessary on a reasonable timeline to return to compliance and to pay penalties and costs authorized by law or this Article.

Sec. ~~2011~~.19.3 Termination of Service and Revocation of Permit.

In addition to other statutes or rules authorizing termination of service for delinquency in payment for sewer service, the District may revoke any permit issued pursuant to these regulations. The District may also terminate the sewer or water service to any property, if a violation of any provision of this Article or a permit is found to exist, or if any wastewater discharge into the District's sewer system causes or threatens to cause a condition of contamination, pollution, or nuisance.

When deemed necessary for the preservation of public health or safety, or for the protection of public or private property, the District may suspend or terminate sewer or water service to any person using the sewer system in a manner endangering the public health or safety, or public or private property. If such endangerment shall be imminent, the District may act immediately to suspend sewer service without notice or warning to said discharger. In terminating service, the District may sever all pertinent connections to the public sewer.

Sec. ~~2011~~.19.4 Permit Amendment.

In the event that the user demonstrates non-compliance or potential non-compliance with the limitations set forth in this Article or in any permit, agreement, or other authorization issued in accordance with this Article, the District may require the user to obtain a Special Use Permit or may modify an existing permit.

Sec. ~~2011~~.19.5 Cost Recovery.

A person violating this Code or a permit or agreement or other authorization issued in accordance with this Article, or who discharges wastewater that causes a deposit, obstruction, damage, or any other impairment to the District's sewer system shall become liable for all expense, loss, or damage sustained by the District by reason of such violation or discharge. Such expenses, losses and damages include the District's costs of investigation and of taking any enforcement action required to return the user to compliance.

In addition to such costs, the District may recover reasonable attorneys' fees, court costs, court reporters' fees and other expenses of litigation by means of an appropriate lawsuit or

other remedy against the person or discharger found to have violated these regulations or any discharge permit issued.

The District may condition the provision or continued provision of service on the payment of such expenses, losses, and damages.

Sec. 2011.19.6 Administrative Complaint – Pretreatment Violations.

- a) In accordance with Section 54740.5 of the Government Code, the Authorized Inspector may issue an administrative complaint to any person who violates any requirement adopted or ordered by a local agency pursuant to Section 2011.9. The administrative complaint shall allege the act or failure to act that constitutes the violation of the requirements, this Section, and the proposed civil penalty.
- b) The administrative complaint shall be served by personal delivery or certified mail on the person subject to the discharge requirements, and shall inform the person served that a hearing shall be conducted within 60 days after the person has been served. The hearing shall be before a hearing officer designated by the General Manager. The person who has been issued an administrative complaint may waive the right to a hearing, in which case no hearing will be conducted. A person dissatisfied with the decision of the hearing officer may appeal to the Board within 30 days after notice of the hearing officer's decision.
- c) If after the hearing, or appeal, if any, it is found that the person has violated reporting or discharge requirements, the hearing officer or Board may assess a civil penalty against that person. In determining the amount of the civil penalty, the hearing officer or Board may take into consideration all relevant circumstances, including, but not limited to, the extent of harm caused by the violation, the economic benefit derived through any noncompliance, the nature and persistence of the violation, the length of time over which the violation occurs and corrective action, if any, attempted or taken by the discharger.
- d) Civil penalties may be imposed as follows:
  1. In an amount which shall not exceed two thousand dollars (\$2,000) for each day for failing or refusing to furnish technical or monitoring reports.
  2. In an amount which shall not exceed three thousand dollars (\$3,000) for each day for failing or refusing to timely comply with any compliance schedule established by the Authorized Inspector.
  3. In an amount which shall not exceed five thousand dollars (\$5,000) per violation for each day for discharges in violation of any waste discharge limitation, permit condition, or requirement issued, reissued, or adopted by the District.

4. In an amount which does not exceed ten dollars (\$10) per gallon for discharges in violation of any suspension, cease and desist order or other orders, or prohibition issued, reissued, or adopted by the District.
  5. The amount of any civil penalties imposed under this section which has remained delinquent for a period of 60 days shall constitute a lien against the real property of the discharger from which the discharge originated resulting in the imposition of the civil penalty. The lien provided herein shall have no force and effect until recorded with the county recorder and when recorded shall have the force and effect and priority of a judgment lien and continue for 10 years from the time of recording unless sooner released, and shall be renewable in accordance with the provisions of Sections 683.110 to 683.220, inclusive, of the Code of Civil Procedure.
- e) All moneys collected under this section shall be deposited in a special account of the District and shall be made available for the monitoring, treatment, and control of discharges into the District's sewer system or for other mitigation measures.
  - f) Unless appealed, orders setting administrative civil penalties become effective and final upon issuance thereof, and payment shall be made within 30 days. Copies of these orders shall be served by personal service or by registered mail upon the party served with the administrative complaint and upon other persons who appeared at the hearing and requested a copy.
  - g) The local agency may, at its option, elect to petition the superior court to confirm any order establishing civil penalties and enter judgment in conformity therewith in accordance with the provisions of Sections 1285 to 1287.6, inclusive, of the Code of Civil Procedure.
  - h) No penalties shall be recoverable under this section for any violation for which civil liability is recovered under Section 54740 of the Government Code.

Sec. ~~2011~~.20 Public Nuisance.

- a) Discharge of wastewater in any manner that is in violation of this Article or a permit, or any order issued by the District as authorized herein, is hereby declared a public nuisance and shall be corrected or abated as directed by the District. Any person creating such a public nuisance is guilty of a misdemeanor and may be referred for criminal prosecution.
- b) If any wastes or waters are discharged, or are proposed to be discharged to the public sewers, which waters contain the substances or possess the characteristics prohibited under this Article, and which in the judgement of the District, may have a deleterious effect upon the sewage works, processes, equipment, or receiving waters, or which otherwise create a hazard to life or constitute a public nuisance, the District may:
  1. Reject the wastes,

2. Require pretreatment to an acceptable condition for discharge to the public sewers,
3. Require control over the quantities and rates of discharge,
4. Require discharger to obtain and comply with an Special Use Permit under this Article,
5. Require payment to cover the added cost of handling and treating the wastes not covered by the sewer charges levied by the District, and/or
6. Take any or all enforcement actions available to the District for violations of this Article.

Sec. 2011.21 Civil Enforcement.

Sec. 2011.21.1 Injunction.

Whenever a discharge of wastewater or other action is found to be in violation of this Code or a permit, or otherwise causes or threatens to cause a condition of contamination, pollution, or nuisance, the District may petition the Superior Court for the issuance of a temporary restraining order, preliminary injunction, permanent injunction, or all, as may be appropriate to restrain such action or require compliant actions.

Sec. 2011.21.2 Other Actions.

The District may take any other civil action available at law or in equity to enforce the provisions of this Code.

Sec. 2011.21.3 Criminal Enforcement.

Violations of this Code may constitute violations of other federal, state, or local laws. The District may refer such violations to the appropriate law enforcement agency for prosecution.

Sec. 2011.22 Appeal Process.

Sec. 2011.22.1 Appeals of Determinations and Redeterminations of EDUs.

- a) The owner of a property subject to a determination or redetermination made in accordance with Section 2011.7 may appeal that determination or redetermination to the General Manager within fifteen (15) days after the District delivers notice of the determination or redetermination in accordance with Section 2011.23 by submitting a written appeal and supporting documentation.
- b) The appellant may submit evidence and the hearing officer shall only consider evidence that is relevant to whether the determination or redetermination was made in error and whether an alternative determination or redetermination is justified,



such as evidence that discharges will be lower than the typical industry values identified in the schedule or otherwise determined by the District.

- c) The hearing officer will grant the appeal in whole or in part if it determines that the evidence submitted by the appellant justifies an alternative determination.

Sec. 2011.22.2 Appeals of Special Use Permit Requirements.

- a) Any person subject to a Special Use Permit issued in accordance with Section 2011.9 may appeal any term or condition included in the Special Use Permit to the General Manager within fifteen (15) days after the Special Use Permit is delivered in accordance with Section 2011.23 by submitting a written appeal and supporting documentation.
- b) The appellant may submit evidence and the hearing officer shall only consider evidence regarding (a) the discharger's ability to meet the District's effluent standards; (b) the requested variance and its impacts on the operation of any District wastewater treatment plant or improvements.
- c) The hearing officer will grant the appeal in whole or in part if the following criteria can be demonstrated: (a) that the discharger is unable to meet the District's effluent standards by means of reasonable modifications to the discharging facility; (b) that the requested variance will not directly impact the operation of any District wastewater treatment plant or improvements, cause the wastewater or sludge of such plant to violate applicable requirements, or harm facilities or personnel; and (c) that the easing of any effluent standards will not violate any State or Federal requirements applicable to the District.

Sec. 2011.22.3 Appeals of Administrative Enforcement Actions.

- a) Any person subject to an administrative enforcement action appeal from the issuance thereof to the General Manager within fifteen (15) days of the date of delivery of the administrative enforcement action by the Authorized Inspector. A person subject to an order to remedy a condition which poses an immediate threat to the public health, safety or welfare shall comply with that order during the pendency of any appeal.
- b) The only issues on appeal may be whether there was a violation as alleged in the administrative enforcement action and whether the appellant is the person responsible for the violation or corrective action.
- c) The amount of any fine or penalty imposed with the administrative enforcement action must be submitted together with the written appeal. Any fine which has been deposited shall be refunded if it is determined, after a hearing, that the person subject to the administrative enforcement action was not responsible for the violation or that there was no violation as alleged in the administrative enforcement action.

Sec. ~~2011~~.22.4 Hearing on Appeal.

- a) Whenever a hearing is required or held in accordance with this Article, the General Manager or hearing officer appointed by the General Manager shall endeavor to set a date for the hearing that is not less than fifteen (15) and not more than sixty (60) days after the date that the written appeal is filed.
- b) The District shall notify person requesting the hearing of the time and place set for the hearing at least ten (10) days prior to the date of the hearing.
- c) The failure of any person requesting a hearing to appear at the hearing shall constitute a forfeiture of the appeal and any fine, and shall be a bar to judicial review of the action based upon a failure to exhaust administrative remedies.
- d) The hearing officer shall only consider evidence that is relevant to the issues identified in this Section.
- e) The appellant shall be given the opportunity to testify and present witnesses and evidence concerning the administrative citation.
- f) The District's determination or redetermination, permit or agreement, or administrative enforcement action and any additional document created by the District shall constitute prima facie evidence of the respective facts contained in those documents. Formal rules of evidence shall not apply.
- g) Upon request, the person requesting a hearing shall be provided with copies of the citations, reports and other documents submitted or relied upon by the District when taking the action subject to the appeal. In addition, if the District submits any additional written reports concerning action subject to the hearing to the hearing officer for consideration at the hearing, then a copy of said documentation also shall be served by mail on the person requesting the hearing.
- h) The hearing officer may continue the hearing and request additional information from the District or the person requesting the hearing prior to issuing a written decision.
- i) After considering all of the testimony and evidence submitted at the hearing, the hearing officer may immediately issue a verbal decision or may issue a written decision within ten (10) days of the hearing. The decision shall include the reasons for the decision and such decision shall be final. If the hearing officer determines that the administrative citation should be upheld, then the fine amount on deposit with the city shall be retained by the city. If the hearing officer determines that an administrative citation should be canceled and the fine was deposited with the city, then the city shall promptly refund the amount of the deposited fine.
- j) If any action is not timely appealed as provided in this Article, the action becomes final.

Sec. 2011.22.5 Appeal to Board.

The decision of a hearing officer issued in accordance with this Article may be appealed to the Board within fifteen (15) days after delivery of the notice of such decision in accordance with Section 2011.23. An appeal under this Section must be submitted to the General Manager on a form or in a format specified by the District. The only issue on appeal shall be whether the decision of the hearing officer is supported by the evidence.

Sec 2011.22.6 Judicial Review.

Any person subject to a decision of the Board on an appeal of a decision of a hearing officer may obtain review of the decision of the Board by filing a petition with the Superior Court of San Diego in accordance with the timelines and provisions applicable to writs of mandate under Code of Civil Procedure section 1094.5.

Sec 2011.23 Delivery of Notice.

Notice of any administrative enforcement action or other action of the District required be delivered pursuant to the requirements of this Article shall be subject to the following:

- a) Notice of any administrative enforcement action shall state that the recipient has a right to appeal the matter as set forth in Section 2011.22 of this Article.
- b) Notice shall be delivered by personal service to the recipient, deposit in the U.S. mail, postage prepaid for first class delivery, by facsimile service with confirmation of receipt, by posting on the property, or by any other means permitted by law, including by electronic mail on consent of the person receiving the notice.
- c) Delivery shall be deemed complete as follows:
  1. Upon personal service;
  2. As indicated on the return receipt of any notice mailed by certified mail, return receipt requested;
  3. Three (3) days after deposit in the U.S. mail, postage pre-paid for first class deliver; or
  4. Where the owner or occupant of any property cannot be located after the reasonable efforts any notice shall be deemed delivered after posting on the property for a period of five (5) business days.
- d) Where the recipient of notice is the owner of the property, the address for notice shall be the address from the most recently issued equalized assessment roll for the property or as otherwise appears in the current records of the City.

**ARTICLE 20 (Renumbered  
as Article 11 by Resolution  
5006)**

Revised in its entirety – 6/93,  
6/94, 6/95, 9/96  
Sec. 20.7, Sec. 20.7.2 – Rev.  
6/99  
Sec. 20.6 – Rev. 11/99  
Sec. 20.5.4 & 20.5.5 – Rev.  
6/06  
Sec. 20.7.1 & 20.7.2 – Rev.  
6/06  
Sec. 20.6.1 – Rev. 10/06  
New Sec, 20.6 – Added 2//07  
Sec. 20.7.5; 20.7.8; 20.8;  
20.8.1; 20.8.2 – Rev. 6/07  
20.8.1 – Rev. 3/08  
20.7.2, 20.7.4, 20.7.5, 20.7.6,  
20.8, 20.8.2 – Rev. 6/08  
Sec. 20.7.2 – Rev. 8/08  
Sec. 20.8.1, 20.8.2 – Rev.  
6/09  
Sec. 20.11 – Rev. 12/10  
Sec. 20.8.2 – Rev. 5/11  
Sec. 20.8.1 – Rev. 6/11  
Sec. 20.8.1 – Rev. 4/12  
Sec. 20.2, 20.4, 20.6.2, 20.6.3,  
20.7.1, 20.7.2, 20.7.3, 20.7.4,  
20.7.5, 20.7.6, 20.8.2 – Rev.  
6/12  
Sec. 20.7.2, 20.7.3 – Rev.  
7/12  
Sec. 20.8 – Rev. 6/13  
Sec. 20.8.1, 20.8.2 – Rev.  
6/14  
Sec. 20.8.1, 20.8.2 – Rev.  
6/15  
Secs. 20.5.2 (add), 20.8.1,  
20.8.2 – Rev. 7/16  
Secs. 20.5.2, 20.8, 20.8.2 –  
Rev. 12/18  
Sec. 20.7.2 – Rev. 7/19  
Revised in its entirety – 8/20  
Sec. 20.16.2, 20.16.4, 20.16.5  
– 12/20

**Article ~~24~~12. Water and Sewer Rates and Service Charges.**

Water and sewer rates and charges are set to fully recover the District's costs. In order to help stabilize the revenue of the District during increasing or decreasing sales, the District has established a policy to collect approximately 80% of the District's fixed water operating costs through the monthly fixed charges and collect the remaining approximately 20% of the District's fixed operating cost through volumetric water rates. The rates and charges are set based upon cost of service principals that meet legal requirements and industry standards.

Effective January 1, 2021, the following rates for water deliveries to each class of service are established:

**Sec. ~~24~~12.1 Volumetric Water, Recycled Water and Pumping Rates.**

For purposes of determining water rates, one unit equals 1,000 gallons:

Domestic (D), Large Lot Domestic (LD).

1-5 units per month .....	\$6.83 per unit
6-30 units per month .....	\$6.92 per unit
Over 30 units per month .....	\$8.44 per unit

Commercial (C).

All usage .....	\$7.03 per unit
-----------------	-----------------

Multi-Unit (M) (Tier ranges factor residential units, per Article ~~19~~ 10.1).

1 - 5 units per month .....	\$6.83 per unit
6 - 30 units per month .....	\$6.92 per unit
Over 30 units per month .....	\$8.44 per unit

Government (G).

All usage .....	\$6.91 per unit
-----------------	-----------------

Irrigation Only (I).

All usage .....	\$7.04 per unit
-----------------	-----------------

SAWR - Ag Only (AS).

All usage .....\$5.06 per unit

SAWR - Ag & Home (AT).

1-5 units per month .....\$6.83 per unit

6-17 units per month .....\$5.86 per unit

Over 17 units per month .....\$5.06 per unit

Commercial Ag (CA).

All usage .....\$5.86 per unit

Commercial Ag Domestic (CB).

1-5 units per month .....\$6.83 per unit

Over 5 units per month .....\$5.86 per unit

Drought Rates

In order to prepare and manage future periods of water shortage and mandatory conservation, the District adopted a water shortage contingency plan called the Water Shortage Response Program (the “Program”). Pursuant to the Program, the District established four Water Shortage Response Levels. Article ~~26~~ 17 Water Shortage Response Program provides information on the program and the applicable water use rates.

Volumetric Recycled Water Rate.

Recycled water furnished within the District service area for any appropriate purpose will be billed at \$5.84 per 1,000 gallons. Recycled water sold outside the District service area will be sold by contract with specific customers. For San Diego County Water Authority and Metropolitan Water District rebate purposes, reclaimed water rates must be set at higher of 85 percent of lowest applicable potable water rate or 80 percent of the average of Tier 1 and Tier 2 rates.

Construction Meter.

Water furnished for construction purposes will be billed at \$8.70 per 1,000 gallons.

Volumetric Pumping Charges. (DSA and Toyon only)

Pumping charges for the DeLuz High Pressure Service Area and Toyon Heights shall be furnished at \$0.84 per 1,000 gallons to recover the cost of electricity.

Sec. ~~24~~ 12.2 Monthly Fixed Charges.

Effective January 1, 2021, the following rates and charges are established and shall be collected by the District for water and recycled water service:

Monthly Service Charges for each meter (\$/meter size):

	Water Fixed Charges	Recycled Water Charges	Standby Service Charge	Private Fire Services Charge
3/4 inch meter	\$53.52	\$24.02	\$24.02	NA
1 inch meter	\$81.70	\$32.52	\$32.52	NA
1-1/2 inch meter	\$152.12	\$53.77	\$53.77	NA
2 inch meter	\$236.65	\$79.27	\$79.27	\$11.67
3 inch meter	\$462.01	\$147.29	\$147.29	\$12.44
4 inch meter	\$715.55	\$223.81	\$223.81	\$13.78
6 inch meter	\$1,419.85	\$436.34	\$436.34	\$18.57
8 inch meter	NA	NA	NA	\$26.84

NA- Not applicable

For construction meters, a service charge of \$354.98 per month or fraction thereof will be made in addition to the cost of water consumed. This rate is calculated using a factor of 1.5 times the fixed charge for a 2” water meter.

The foregoing fixed charges for water service through various sized meters that are installed or upgraded will be effective commencing the day of installation, regardless of the amount of water used, as long as the consumer's property is actually connected with the District's distribution system. In addition, any request to down size a meter properly filed with the District will receive a fixed charge commensurate with the meter size effective the next billing cycle.

Billings for water furnished to all accounts will be on a monthly basis.

A monthly service charge to cover the District's cost for annual inspection, maintenance, repair and replacement of backflow prevention devices will be made as follows (\$/meter size):

For each 3/4 inch device	\$5.90
For each 1 inch device	\$6.95
For each 1-1/2 inch device	\$12.86
For each 2 inch device	\$15.42
For each 3 inch device	\$30.81
For each 4 inch device	\$48.15
For each 6 inch device	\$96.28

Sec. 2412.3 MWD Readiness-to-Serve Charge (RTS) and SDCWA Infrastructure Access Charge (IAC).

Effective January, 2021, the following monthly charges are established and shall be collected by the District for the Metropolitan Water District of Southern California’s Readiness-to-Serve (the “RTS”) charge and San Diego County Water Authority’s Infrastructure Access Charge (the “IAC”).

Monthly charges for each meter (\$/meter size):

	RTS	IAC
3/4 inch meter	\$1.95	\$3.64
1 inch meter	\$3.26	\$6.08
1-1/2 inch meter	\$6.49	\$12.12
2 inch meter	\$10.39	\$19.40
3 inch meter	\$20.81	\$38.86
4 inch meter	\$32.51	\$60.72
6 inch meter	\$64.99	\$121.39

Sec. ~~21~~12.4 Water Capital Improvement Charge.

For each water account, an additional \$9.77 per month per Equivalent Meter Unit (EMU) shall be added as a Capital Improvement Charge effective January 1, 2021. This charge is solely dedicated to funding water capital improvement projects. The Water Capital Improvement Charge (the “CIC”) was implemented to provide a partial funding source for capital projects like the UV treatment facility at the Red Mountain Reservoir and to fund pipeline replacement projects.

Water Capital Improvement Charges will be adjusted annually based on the ENR (Engineering News Record) Construction Cost Index (CCI) of February, plus 3% not to exceed 10%. Staff will report back to the Board of Directors no less than every five (5) years with analysis of its necessity. The Capital Improvement Charge will be used to fund capital improvement projects or debt service for capital improvement projects. Revenue from the Capital Improvement Charge will not be used to fund Operating Costs.

Fallbrook Public Utility District’s Equivalent Meter Unit (EMU) is associated with meter size as listed below.

Meter Size	FPUD EMU	Water CIC	Water CIC (Standby Service)
3/4 inch meter	1.0	\$9.77	\$4.42
1 inch meter	1.67	\$16.27	\$7.37
1-1/2 inch meter	3.33	\$32.55	\$14.75
2 inch meter	5.33	\$52.07	\$23.60
3 inch meter	10.67	\$104.14	\$47.19
4 inch meter	16.67	\$162.72	\$73.73
6 inch meter	33.33	\$325.43	\$147.46

An additional, a Water CIC Pumping charge of \$.10 per 1,000 gallons is charged and allocated to capital improvements for the DeLuz High Pressure service area and Toyon Heights zone. This Capital Improvement Charge will be adjusted annually based on the ENR (Engineering News Record) Construction Cost Index (CCI) of February, not to exceed 10% annually.



Sec. ~~21~~12.5 Billing Periods.

Billing due dates fall on the 10th, 20th, and 30th of the month depending on meter location in the District. All charges for water and sewer services during specified meter read dates are due and payable when rendered. Bills become delinquent the day after the due date. Residential accounts not paid within 30 days of the due date are sent past due statements and the meters are subject to lock-up for non-payment (See District Residential Discontinuation of Service Policy available on the District website). Non-Residential accounts not paid within 30 days of the due date are subject to meter lock-up. All water accounts accrue a \$30 Delinquent Processing Fee on the 31st day of delinquency.

Accounts not paid within 30 days after lock-up and accounts that have tampered with the meter to obtain water illegally are subject to removal of meters and permanent disconnection of water service. Standby charges will continue to accrue after the meter has been removed.

If a meter has been locked for non-payment for a period of 90 days, it may be placed on Standby Service by FPUD. Standby Service charges will accrue from that time until an application for service restoration has been received by the District.

The District must be notified in a timely manner with the name and mailing address of the new owner or tenant and the upcoming date of transfer. Notification of the transfer of property ownership, or tenancy, is the responsibility of the owner/seller. The District is not responsible for the proration of the final billing if notification is not received prior to the date of sale, or change of tenancy.

Sec. ~~21~~12.5.1 Unclaimed Funds

Unclaimed funds in an amount less than \$15 or where the depositor's name is unknown will become FPUD general funds if unclaimed for 1 year. Unclaimed funds in an amount greater than \$15 become may become FPUD general funds once the following procedure is completed:

1. The FPUD treasurer will publish notice once a week for two (2) successive weeks in a newspaper of general circulation published within FPUD boundaries.
2. The notice will state the amount of unclaimed money, the formal name of the fund in which the money is held, and a statement that the money will become FPUD property after a specified date ("Effective Date"). The Effective Date will be no less than forty-five (45) days nor more than sixty (60) days of the date of the first publication of the notice ("Claim Period").
3. Upon the expiration of the Claim Period, and if there are no claims filed with FPUD or verified lawsuits filed with the superior court, the funds will become FPUD property and may be transferred to FPUD's general fund.

Any person with a claim to such money may file a claim prior to the Effective Date with the FPUD treasurer. Pursuant to Government Code Section 50052, the claim shall include

the following information: claimant’s name, address, amount of claim, grounds upon which the claim is founded, and any other information that may be required by the FPUD treasurer. FPUD has the right to accept or reject a claim. If the claim is accepted, FPUD will return the money without interest. If FPUD rejects the claim, the claimant may file a verified complaint against FPUD with the superior court within thirty (30) days of receiving notice of FPUD’s rejection pursuant to Government Code Section 50052. In the event that the original customer or depositor is deceased, such person’s heir, beneficiary, or duly appointed representative may file a claim before the Effective Date as provided in Government Code Section 50052.5.

Sec. ~~21~~12.6 Meter Locks and Restrictors.

If for any reason, other than District convenience, a water meter shall be locked by the District, the water may not be again turned on to serve the property through such meter until all past due charges plus the Disconnection Processing Fee of Fifty Dollars (\$50) shall have been paid to the District. A Delinquent Processing Fee of \$30 to process and deliver delinquent account notices and a fee of \$100 for broken or damaged locks may also apply. Damage to corporation or angle stop in attempt to restore services locked for non-payment will be billed at actual time and material and added to the water bill.

If flow restrictors are required for any reason in order to implement policies within this Administrative Code, the fees are as follows:

<u>Meter Size</u>	<u>Installation Fee</u>
3/4” and 1” Meters .....	\$137
1-1/2” and larger .....	\$582

Sec. ~~21~~12.7 Meter Not Registering.

Whenever, for any reason, a meter fails to register correctly, the consumer will be charged an amount for the previous billing period increased or decreased by the percentage change in total billing by the District for all consumers for the two billing periods.

Sec. ~~21~~12.8 Water Rates or Service Charges Lien on Property.

In addition to any other remedy provided therein or by law for the collection of any water rate, charges or account, all rates or service charges provided for in this Administrative Code shall be charged and become a charge against the property on which the water is furnished and against the owner thereof, and all charges for water so served to a property shall be and become a lien against the premises upon which the water is used or served.

Standby accounts with a delinquent balance greater than \$500 as of April 1<sup>st</sup> of each year may be sent notification of intent to place delinquent and unpaid charges on the annual tax roll. The notification will be sent by May 1<sup>st</sup> and provides the customer 60 days to bring the account current. If the amount is not brought current by July 1<sup>st</sup>, the portion of the delinquency due as of the prior April 1<sup>st</sup> may be reported to the County Treasurer for inclusion on the annual taxes levied on the property.

If for any reason or cause the sums of money owing for such water services are not paid as required by the terms and provisions of this Administrative Code, the District shall have the right to shut off such water, and in no case shall service of water be resumed on the same property until all such delinquencies and additional turn-on charges shall have been paid in full. Delinquent bills from former owners or tenants are the responsibility of the present owner.

Sec. ~~24~~12.8.1 Theft of Water.

Water is defined as stolen from the customer if the water is stolen from the customer's side of the meter. Water stolen from a mainline, hydrant, District pipeline, appurtenance, or tampering with a customer's meter is defined as water being stolen from the District.

Water Stolen from Customer.

Customers who have reported water theft to the District must also notify local law enforcement agencies. The District will require proof of theft from a law enforcement agency that a theft of water occurred. Customer's asking for credit on the bill for water theft will be processed by account type. If a full price M&I customer, the District may discount the estimated amount of water stolen and charge the District's wholesale cost of water for the amount stolen. An estimate of the amount of water stolen will be made by District staff using that customer's usage history. Water sold to agricultural customers, SAWR, and Commercial Ag/Commercial Ag Domestic, is sold at District cost so no discount may be applied. If the stolen water caused the customer's allocation bank to be adversely affected, the District will restore the estimated amount stolen to the customer's allocation bank. If the water theft resulted in an overuse penalty, the District will credit the penalty to the customer for the estimated amount of water stolen.

Water Stolen from District.

Any theft of water from the District will be reported to law enforcement agencies. If the theft is due to meter tampering, the customer will be charged a \$250 fee for tampering with the meter plus time and materials to place the meter back into proper position. If a water theft from the District due to meter tampering occurs again on the same meter, the customer will be charged a \$500 fee for tampering and an item will be brought forward to the Board of Directors to consider discontinuance of service. An estimate of the amount of water stolen will be calculated and billed to the customer's account. Collection of said fees are subject to all District regulations regarding collection of past due accounts.

Sec. ~~24~~12.9 Volumetric Wastewater Charges.

Wastewater service charges are established upon each property within the District that is connected to a sewer line of the District whether said premises are occupied or unoccupied. Volumetric Wastewater Charges are applied to estimated billable wastewater flows, which are based upon adjusted water deliveries. The charge per killogallon of wastewater flow is shown below:

User Class	Volumetric Wastewater Charge (\$/kgal)
Ag. Domestic	\$ 10.79
Commercial Ag. Domestic	\$ 10.79
Residential (Single , Multi-family)	\$ 10.79
Government	\$ 10.72
School	\$ 10.72
Church	\$ 10.72
Commercial – Low Strength*	\$ 10.72
Commercial – Medium Strength*	\$ 13.22
Commercial – High Strength*	\$ 16.48

Appendix A to this Article provides commercial effluent classification.

For the purpose of determining the billable wastewater flows, water deliveries must be converted to wastewater flows returned to the sewer system. To do this conversion, a Return to Sewer Factor is applied. The Return to Sewer factor adjusts the water received by the meter to the estimated flows from the residence or entity into the sewer system. The Return to Sewer Factor applied to the different customer classes are shown below:

Cusomer Class	Return to Sewer Factor
Residential (Multi-Family, Single Family)	75%
Non-Residential/Commercial	90%
Low / Medium / High	90%
Government	
Low / Medium / High	90%
Schools	80%
Churches	80%
Special	
Low / Medium / High	100%
Special 10% RTS (1-10%)	
Low / Medium / High	10%
Special 20% RTS (11-20%)	
Low / Medium / High	20%
Special 30% RTS (21-30%)	
Low / Medium / High	30%
Special 40% RTS (31-40%)	
Low / Medium / High	40%
Special 50% RTS (41-50%)	
Low / Medium / High	50%
Special 60% RTS (51-60%)	
Low / Medium / High	60%

Customer Class	Return to Sewer Factor
Special 70% RTS (61-70%)	
Low / Medium / High	70%
Special 80% RTS (71-80%)	
Low / Medium / High	80%

Non-residential customers with higher outdoor are evaluated on a case by case basis.

For those Single Family Residences (D, LD, AT, CB), volumetric charges are calculated as follows:

1. The 2-year average winter use is calculated based upon prior year water deliveries that include December, January and February. The average used for wastewater billing is capped at 21.33 units.
2. 75% of this water is assumed to be returned to sewer/billable flow.
3. The Volumetric Wastewater Charge (\$/kgal) is applied to this flow.
4. Consumption analysis is performed annually. Appeal for consumption is available.
5. No prior history customer (new customer) will be placed at that customer class median of 6. For customers with at least one winter of use data, that data will be used for the their winter average.
6. Use must be > 0 unless customer is on standby.

For those Multi-Family Residences (M), volumetric charges are calculated as follows:

7. The average winter use is calculated based upon prior year water deliveries that include December, January and February.
8. 75% of this water is assumed to be returned to sewer/billable flow.
9. The Volumetric Wastewater Charge (\$/kgal) is applied to this flow.
10. Consumption analysis is performed annually. Appeal for consumption is available.
11. No prior history customer (new customer) will addressed on a case by case basis.

All other water customer classes (G, C, A,, AS, CA), with the exception of public elementary and public junior high schools:

1. Monthly sewer bill based on actual water sold.
2. The Return to Sewer factor applied to determine the billable flow. Appeals for irrigation and/or water usage which does not get returned to the sewer is available.
3. Customer is classified as high, medium, or low strength (based upon BOD and SS). See attached Appendix A. Appeal for strength classification is available.
4. The applicable Wastewater Volumetric Charge is applied to the billable flow.

Public elementary and public junior high schools:

1. Monthly sewer bill based on per person, per month charge.
2. The public elementary and / or public junior high school district to provide a report each October that documents the number of students and faculty at each site.
3. CY 2021 public elementary school rate is \$1.31 per student and \$1.91 per staff, per month.
4. CY 2021 public junior high school and administrative offices rate is \$1.91 per person, per month.
5. Rates to be increased by the overall percentage increase in wastewater revenues each year.

Sec. ~~20~~21~~11~~12.10 Monthly Fixed Wastewater Charge.

For each sewer account, Effective January 1, 2021, the Monthly Fixed Wastewater Charge shall be \$10.60 per month per Equivalent Dwelling Unit (EDU). EDUs will be calculated per Administrative Code Sections ~~20~~21~~11~~12.7.2, ~~20~~21~~11~~12.7.3, or ~~20~~21~~11~~12.7.4.

Sec. ~~20~~21~~11~~12.10.1 Wastewater Capital Improvement Charge.

For each account, an additional \$11.63 per month per Equivalent Dwelling Unit (EDU) shall be added as a Wastewater Capital Improvement Charge Effective January 1, 2021. This charge is dedicated to Wastewater Debt Service and Wastewater Capital Improvements. The Wastewater Capital Improvement Charge has been implemented to partially fund the debt service payments for upgrades to the Wastewater Treatment Plant. EDUs will be calculated per Administrative Code Sections ~~20~~21~~11~~12.7.2, ~~20~~21~~11~~12.7.3, or ~~20~~21~~11~~12.7.4. This Capital Improvement Charge will be adjusted annually based on the ENR (Engineering News Record) Construction Cost Index (CCI) of February, not to exceed 10%. Staff will report back to the Board of Directors every five (5) years with analysis of its necessity. The Capital Improvement Charge will only be used to fund capital improvement projects or debt service for capital improvement projects. Revenue from the Capital Improvement Charge will not be used to fund Operating Costs.

**ARTICLE 21** (Renumbered as  
Article 12 by Resolution 5006)

Sec. 21.1 – Rev. 7/02  
Sec. 21.2-21.8.2 – Rev. 9/96  
Sec. 21.3 – Rev. 10/96  
Sec. 21.4 & 21.9 – Rev. 6/97  
Sec. 21.4 – Rev 7/02  
Sec. 21.9 – Rev. 10/97  
Sec. 21.9 – Rev. 6/04  
Sec. 21.9 – Rev. 1/05  
Sec. 21.1, 21.3, 21.4, 21.9 – Rev.  
6/05  
Sec. 21.1, 21.2, 21.4, & 21.9 –  
Rev. 6/06  
Sec. 21.9, Flat Rate + Metered  
Flow – Rev. 7/06  
Sec. 21.9 (Flat Rate classification)  
– Rev. 10/06  
Sec. 21.4 (construction meters),  
Sec. 21.5 & Sec. 21.6 – Rev.  
12/06  
Sec. 21.5 – Rev. 3/07  
Sec. Sec. 21.1, 21.2, 21.4 , 21.10,  
21.10.1– Rev. 6/07  
Sec. 21.5 – Added 6/07  
Sec. 21.10.2 – Deleted 6/07  
Sec. 21.11 – Added 10/07  
Sec. 21.4.1 – Added 12/07; Sec.  
21.7 renamed and addition of flow  
restrictors – Rev. 12/07  
Sec. 21.1, 21.2, 21.4, 21.5, 21.7,  
21.10, and 21.11 – Rev. 6/08  
Sec. 21.1, 21.2, 21.4, 21.4.1,  
21.4.2 (added), 21.5, 21.7, 21.10  
(new table), 21.10.1, - Rev. 6/09  
Sec. 21.4, 21.10 – Rev. 12/09  
Sec. 21.6, 21.9 – Rev. 5/10  
Sec. 21.1, 21.2, 21.4, 21.4.1,  
21.4.2, 21.5, 21.10, 21.10.1 – Rev.  
6/10  
Sec. 21.9.1 (added) – Rev. 9/10  
Sec. 21.1, 21.4, 21.4.1, 21.4.2,  
21.5, 21.10, 21.10.1 - Rev. 6/11  
Sec. 21.1, 21.2, 21.4, 21.5, 21.10,  
21.10.1 – Rev. 6/12  
Sec. 21.1, 21.2, 21.4, 21.5, 21.10,  
21.10.1 – Rev. 6/13  
Sec. 12,1, 21.2, 21.4, 21.5, 21.9.1,  
21.10, 21.10.1 – Rev. 6/14  
Sec. 21.1, 21.2, 21.5 – Rev. 1/15  
Sec. 21.1, 21.2, 21.3, 21.4, 21.4.2,  
21.5, 21.10, 21.10.1 Rev 6/15  
Sec. 21, 21.1 – Rev. 11/15  
Secs. 21, 21.2, 21.4, 21.5, 21.7,  
21.10, 21.10.1 – Rev. 7/16  
Secs. 21, 21.1 - Rev. 12/16  
All Secs. – Rev. 12/17  
Sec. 21.3 – Rev. 6/18  
Secs. 21.1, 21.2, 21.3, 21.4, 21.9,  
21.10, 21.10.1 – Rev. 12/18  
Sec. 21.3 – Rev. 6/19

**ARTICLE 21 CONTINUED**  
(Renumbered as Article 12 by  
Resolution 5006)

Secs. 21, 21.1, 21.2, 21.3, 21.4,  
21.5, 21.9, 21.10, 21.10.1 – Rev  
12/19

Secs. 21.5, 21.6, 21.5.1 (added) –  
Rev. 1/20

Sec 21.3 – Rev 6/20

Secs. 21, 21.1, 21.2, 21.3, 21.4,  
21.9, 21.10, 21.10.1 – Rev 12/20



**Article 2213.**      **Easements.**

Sec. 2213.1    Requirement for Easements.

Whenever a pipeline is constructed, a meter is installed, an extension of a line is made, or a fire hydrant installed, the District requires an easement in order to go on the property.

Sec. 2213.2    Acceptance of Easements.

The District accepts easements for right-of-way for District pipelines and facilities, together with right of ingress and egress for the purpose of construction, repairing, relaying, enlarging and operating same.

On January 26, 1987, the Board of Directors authorized the General Manager to approve all easements received and the President and Secretary to sign them and prepare them for recordation upon the necessary information provided by the legal owner.

Sec. 2213.3    Granting of Easements.

Granting of easements must be approved by the Board of Directors. Staff will determine whether the District will grant an easement over District property or over easements the District has that allows for reconveyance to others.

ARTICLE 22 (Renumbered as Article 13 by Resolution 5006)
Sec. 22.3 – Rev. 6/93
Sec. 22.1 – Rev. 11/94
Sec. 22.3 – Rev. 6/95
Sec. 22.1-22.3 – Rev. 9/96

**Article 2314.            Construction, Regulations Governing.**

**Sec. 2314.1    Water Line Extensions and Replacements by the District.**

As finances permit, the District will repair and replace the system of mains, storage reservoirs, pumps and controls that are existing, maintained, and operated by the District. Storage reservoirs connected by these mains will be located at convenient high points within the District so that reasonable pressures under gravity flow can be provided to the consumers around them. Pressures higher than those available under gravity flow will not be provided by the District except as may be considered under a special rate Ordinance.

Extensions desired beyond the existing system in service shall be provided by others desiring the extensions.

The District can fund pipeline looping projects, when all properties are served and a short pipeline section is needed to loop the end of the pipeline to another pipeline in the distribution. When this occurs in a subdivision or other development project, the project plans of improvement must include all District pipeline improvements, both private and District funded portions, prior to being approved by the District.  
*Ordinance No. 226.*

**Sec. 2314.2    Water Line Extensions, privately financed.**

The following terms and conditions shall apply to extensions and others who provide them:

- a) An extension, at the expense of others, may be required as a condition of service where the property to be served does not abut a District pipeline. A required pipeline extension shall extend a minimum of 20 feet beyond the property line into the property.
- b) An extension, at the expense of others, shall be required as a condition of service where the property to be served does not abut a District pipeline and where the land is to be part of a subdivision or a similar development. For minor subdivisions (5 parcels or fewer) the pipeline extension shall extend a minimum of 20 feet into the last parcel to be served.
- c) The District will accept, maintain and operate those extensions constructed to its standards and requirements by others. Whenever an extension is to be provided by others, it shall conform to the then current Standard Specifications for Distribution System Construction, as approved by the Board of Directors.
- d) The location of all extensions and service connections shall be at the discretion of the District.
- e) Whenever it is not possible for an extension provided by others to lie within a County Road, the District shall require that an easement, normally thirty (30) feet in width, be provided, which will enable the District to maintain and replace the pipeline.
- f) An extension to serve a major subdivision (greater than 5 parcels) or other property being similarly developed may be required to the far edge of the last lot served.

- g) All extensions shall be constructed with pipe of a size adequate in the judgment of District staff to serve the area and the minimum size shall be six (6) inches.
- h) Fire hydrant installations as required by the North County Fire Protection District and then existing ordinances of San Diego County shall be provided as an integral part of all extensions.
- i) The District can approve exceptions to these requirements in the form of a Remote Meter Agreement per Section [19\\_10.2](#) or a Temporary Service Agreement per Section [19\\_10.3](#).

Sec. [2314.3](#) Repayment Agreements - Water and Sewer Line Improvements.

Improvements provided by others which benefit owners fronting upon but not contributing toward the cost at the time of construction may be subject to a privately financed extension agreement for the collection and refunding of part of the cost. The Agreement consists of the following:

- a) The District will have title to the improvements and will operate and maintain them as a part of the District's system.
- b) The District agrees to collect a proportionate contribution for the cost of the improvements to provide service to those adjoining lands benefiting from them for a period of 10 years or until all proportionate charges have been collected and refunded, whichever period is less.
- c) The District agrees to refund to the financing owners the proportionate contribution funds that are collected.
- d) The District will have the sole authority to permit connections to or extensions from and service connections to said privately financed improvements.
- e) The basis upon which proportions of the cost of the improvement(s) shall be computed for each privately financed extension agreement shall be negotiated by the Board of Directors with the financing owners and shall generally consist of practicable front footage, acreage, number of service connections, or such other basis as may be determined by the Board of Directors to be equitable to the financing owners and other benefiting property owners.
- f) The improvement(s) will be installed in an easement granted to the District free of liens and encumbrances.

[2314.3.1](#) Administrative Costs. The administrative cost to the financing owners shall be one hundred dollars (\$100) and shall be collected by District at the time such privately financed extension agreement is entered into.

Payment for District service(s) that has been used on any parcel of land shall have been made in full before the parcel is to be eligible to receive service from a new extension or service connection.

Sec. [2314.4](#) Pipeline Extensions - Sewer.

2314.4.1 Process. If an Applicant seeks an application for sewer service for property which is not adjacent to a District sewer system pipeline, the Applicant shall be required to enter into a written agreement with the District to construct additional facilities determined necessary by the District at the time the application is submitted.

2314.4.2 Agreement. No pipeline extension shall be allowed unless the Applicant executes the agreement entitled "Agreement for Construction of Sewer Facilities to be Dedicated to the Fallbrook Public Utility District".

2314.4.3 Fees. For line extensions, the Applicant shall pay the District a cash deposit computed as follows:

- (a) Inspection fees of \$5 per lineal foot;
- (b) One hundred fifty percent (150%) of the District's estimate of the total construction costs for the line extension, or one hundred fifty percent (150%) of the actual bid secured by the applicant for the work, if lower.

Sec. 2314.5 Construction Ownership and Maintenance of Sewer Lateral Pipelines.

The sewer lateral pipeline is that portion of the service lateral between the connection to the common sewer main and the service cleanout, located typically at the edge of the right-of-way where it connects with the owner lateral.

The installation of sewer lateral pipelines and connection of sewer lateral pipelines to the sewer main transmission lines of the District shall be done only by personnel of the District. The District is authorized to contract for such installation and connection when personnel of the District are not available to install and connect the lateral pipeline. The contract work shall be inspected and approved by the District before acceptance of the work by the District.

The entire sewer lateral pipeline and owner lateral from the connection to the common sewer main to the house connection shall belong to and be the property of the Owner. The common sewer main, including all manholes and appurtenances, shall belong and be the property of the District. The District may maintain that portion of the Owner's lateral between the common sewer main and the service cleanout upon the request of the Owner. The District may repair that portion of the Owner's lateral between the common sewer main and the service cleanout upon the request of, and at the expense of, the Owner.

Sec. ~~23~~14.6 Temporary Sewer Service Connections.

A Temporary Sewer Service Agreement is a recorded agreement between the District and a consumer that a connection will be placed temporarily at a location which must be pumped to serve the property, where the District intends, at some future date, to extend the District collection system to abut, or cross, the property described in the agreement, and that the consumer is responsible for extending his own temporary private lateral from the main to his property, obtaining whatever temporary easements are required for such extension, and maintaining private pump stations in a sanitary fashion, free of odors. Such agreements shall establish the financial obligations of the consumer related to the future installation costs of the District's collection system and the cost of connection to the gravity main, and shall be binding upon the signatory and all successor owners of said property.

Failure to comply with the terms of the agreement shall be cause for termination of sewer service to said property and the basis for establishing a lien against the property for collection of any amounts due the District. Upon change of ownership, any parcel receiving sewer service under a Temporary Sewer Service Agreement will be required, as a condition of continued service, for the new owner to enter into a new Temporary Sewer Service Agreement with the District.

ARTICLE 23 ([Renumbered as Article 14 by Resolution 5006](#))

- Sec. 23.1 – Rev. 7/94
- Sec. 23.4 – Rev. 6/95
- Sec. 23.5.2 – Rev. 9/96
- Sec. 23.3 - Rev. 1/99
- Sec. 23.5, Sec. 23.5.1- Rev. 6/99
- Sec. 23.6 – Added 11/99
- Sec. 23.5 – Rev. 1/01
- Sec. 23.5 – Rev. 6/07
- Secs. 23.1, 23.2 – Rev. 7/19

**Article 24 15.**      **Standby or Availability Charges**

Sec. **2415.1**    **Definition.**

In accordance with Division 7, Chapter 4, Article 3, Sec. 16475 and 16477 of the Public Utility District Act, the Board of Directors has the authority to establish standby or water availability charges, not to exceed \$30.00 an acre.

Sec. **2415.2**    **Water Availability Charges.**

Water availability charges are hereby fixed and established on all land within the District boundaries, whether the water is actually used or not, as follows:

The term "parcel" as used herein shall mean a parcel of land as shown upon the assessment rolls of the County Assessor of San Diego County; provided that where a legal final subdivision map has been approved, "parcel" shall mean each separate lot within the subdivision.

**2415.2.1**    **Fallbrook Service Area.**

(a) \$10 (ten) per acre for all parcels one (1) acre or more prorated out to one hundredth of an acre, as set forth in the San Diego County Tax Assessor's maps, EXCEPTING lands permanently dedicated exclusively to transportation of persons or property, hereafter referred to as the transportation dedication exclusion. For purposes of this Administrative Code, it is assumed that 5% of all parcels have been permanently dedicated exclusively to transportation of persons and property; therefore, the actual assessment will be \$9.50 per gross acre, as set forth in the San Diego County Tax Assessor's maps.

(b) \$5 (five) for parcels of less than one acre. For purposes of this Administrative Code, all parcels with gross acreage of 1.05 acres are considered to have a net acreage of less than one acre for purposes of the transportation dedication exclusion.

**2415.2.2**    **DeLuz Improvement District.**

(a) Acreage adjacent to or lying within 1320 feet of water distribution line \$10.00 per acre.

(b) Acreage between 1320 and 2640 feet of a water distribution line – \$ 9.00 per acre.

(c) Acreage between 2640 and 3960 feet of a water distribution line – \$ 8.00 per acre.

(d) Acreage between 3960 and 5280 feet of a water distribution line – \$ 7.00 per acre.

(e) Acreage over 5280 feet from water distribution line -\$ 6.00 per acre.

(f) All parcels of less than one acre - \$ 5.00.

Sec. 2415.3 Exemptions.

Lands not using District water and obtaining water primarily from rainfall, springs, streams, lakes, rivers, or wells, and where the primary economic activity on the land is the commercial extraction of minerals, are exempt.

Sec. 2415.4 Collection of Standby/Availability Charges.

On or before August 10 of each year, the Secretary of the District shall furnish in writing to the Board of Supervisors of San Diego County and to the County Auditor a description of the land within the District upon which standby or availability charges are to be levied and collected, together with the amount of the charges. At the time and in the manner required by law for the levying of taxes for County purposes, the Board of Supervisors shall collect, in addition to taxes it levies, water availability charges in the amounts fixed by this Administrative Code for the respective parcels of land described in Sec. 23 14.2.1 and Sec. 23 14.2.2 of this Code. All County officers charged with the duty of collecting taxes will collect the charges with the regular tax payments in the same form and manner as County taxes are collected. Such availability charges are a lien on the property with respect to which they are fixed. Collection of the charges may be enforced by the same means as provided for the enforcement of liens for State and County taxes.

Sec. 2415.5 Deferral of Charge.

Situations may arise when an owner of a parcel of land does not use and has no present intention of using water provided by the District, a member agency of the San Diego County Water Authority. The purpose of this section is to permit an evaluation by the District, on a case-by-case basis, of the circumstances which pertain to such situations to determine whether a deferral of charges should be approved according to the terms and conditions herein provided.

2415.5.1 Application. Any owner of a parcel of land who believes that the amount of the Water Standby Availability Charge fixed against such parcel should be deferred may file an application with the District for deferral of the charge, as follows:

- a) The application shall include a statement describing the circumstances and factual elements which support the request for deferral.
- b) The General Manager shall consider the request within sixty (60) days after the filing of a completed application. If the application for deferral meets the established criteria, the General Manager may decide whether to approve the request and order the charge deferred accordingly. If the request is denied, the applicant shall be notified in writing stating the reasons for the denial.
- c) An application shall be deemed timely as to a charge established for any year if it is filed within three (3) years after the date the ordinance fixing the charge is adopted.

2415.5.2 Appeal to Board of Directors. If the General Manager denies a request, the owner may file an appeal with the Board of Directors within sixty (60) days after such denial. No new application for deferral need be considered by the General Manager until expiration of twelve (12) months from the date of a denial unless differently directed by the Board of Directors.

2415.5.3 Deferred Charges on Restricted Parcels. The levy of the charge may be deferred annually as to any parcel of land which meets each of the following criteria:

a) The owner of such parcel makes a timely application requesting deferral of the charge as defined in subsection 2415.5.1.

b) The parcel, which is the subject of the request, will become subject to enforceable restrictions which prohibit the use of water on the parcel, except by means of natural precipitation or runoff; provided however, if considered appropriate by the General Manager local water may be used for limited domestic, stock watering and irrigation uses.

c) The owner executes a recordable agreement which includes provisions that:

set forth the enforceable restrictions pertinent to the subject parcel;

the agreement may be terminated upon written request by the owner and payment of all deferred Water Standby Availability Charges, plus interest thereon, compounded annually, and accruing at the legal rate from the date such charges would have been otherwise due and payable;

no water service from District sources shall be provided to such parcel for a period of ten (10) years after the total amount due for the charges deferred, plus annually compounded interest, is paid in full to the District;

during the ten (10) year period, while water service is not available to the subject land, the owner pays all annual Water Standby Availability charges as fixed; and

contains such other provisions considered by the General Manager to be appropriate.

2415.5.4 Deferred Charges on Partial Parcels. The District does not allow partial deferments of the Water Availability/Standby charge on a single parcel. Landowners within the District's service area wishing to defer these charges on a portion of their property will need to obtain a separate Assessor Parcel Number (APN) for that property that cannot be developed or planted.



A property owner must submit a map to the San Diego County Assessor's Office, Mapping Division, depicting the owners property and the area(s) to be considered separately, and a request that the Water Availability/ Standby charge be deferred. This will create a new APN and an Owner's Map which is for assessment purposes only.

**2415.5.5** Surcharge. Upon termination of the deferral agreement, an owner may elect to receive water prior to the expiration of the ten (10) year period upon payment of a surcharge. The surcharge shall be equal to the amount of the annual water Standby Availability Charge fixed for the parcel(s) of land in the year of election to receive water service multiplied by the number of years remaining of the ten (10) year period.

**2415.5.6** Refunds. If it is determined that a refund of any previously fixed Water Standby Availability Charge is appropriate because the subject parcel qualifies for deferral of charges, the amount refunded shall be added to the amount of deferred charges due under section **2415.5.3**, c, para. 2, and will be subject to the legal interest rate compounded annually.

**2415.5.7** Enforcement Procedures. In order to insure that terms and conditions of the recordable agreement are being met, the General Manager shall:

- a) maintain a record of all parcels approved for deferral of the Water Standby Availability Charge;
- b) make a written report to the Board of Directors in August of each calendar year showing all parcels with deferred annual Water Standby Availability Charges and the amount of the deferred charges and accrued interest;
- c) cause each such parcel to be physically inspected every three (3) years from the date of deferment;
- d) report to the Board of Directors any instances where the terms of the agreement are being violated; and
- e) take such other actions or procedures considered appropriate.

Sec. **2415.6** Certified Copies.

The Secretary of the District shall deliver certified copies of this Ordinance to the Board of Supervisors and to the Auditor of San Diego County with the list of charges described above.

Sec. 2415.7 Correction of Errors.

The General Manager of the District is hereby authorized to correct any clerical error made in any assessment or charge pursuant to this Administrative Code to make an appropriate adjustment in any assessment or charge made in error.

*Ord. No. 218, 225, 232, 246, 256, 261, 285, and 295.*

ARTICLE 24 (Renumbered as  
Article 15 by Resolution  
5006)

Sec. 24.5.4 – Rev. 9/97

**Article 2516.      Tax Levy**

**Sec. ~~25~~16.1      Definitions.**

Annually, during the Budget process, the Board of Directors makes a determination whether or not budgeted revenues are adequate to pay both the District's budgeted expenditures of the Utility Fund, and the annual principal and interest available on the bonded debt. The District's taxpayers have agreed to pay by taxation any principal and interest on general obligation bonded indebtedness at the time of the bond authorization election. If the Board determines that other revenues are insufficient to meet the debt obligation, then it is necessary for the District to raise money by taxation for the purposes of paying the principal of and interest on the bonded debt of the District as they become due.

**Sec. ~~25~~16.2      General Bonded Indebtedness.**

The Fallbrook Public Utility District will have no principal and interest due on general obligation bonded indebtedness during the current fiscal year.  
*Ordinance No. 257, 262 267, 270, 275, 277, 282, 286, 289, 292, 296, 310, 314, 317.*

**Sec. ~~25~~16.3      Money to be Raised By Taxation.**

The Board of Directors has determined that it will not be necessary to raise by taxation during fiscal year 2007-08 any amount for payment of principal and interest on general obligation bonded indebtedness. *Ordinance No. 257, 262, 267, 270, 275, 277, 282, 286, 289, 292, 296, 310 314, 317.*

**Sec. ~~25~~16.4      Full Valuation of Taxable Property.**

It will not be necessary to set a tax levy for fiscal year 2007-08.  
*Ordinance No. 257, 262, 267, 270, 275, 277, 282, 286, 289, 292, 29, 310, and 314.*

**Sec. ~~25~~16.5      Certified Copies.**

The Secretary of this Board is not required to immediately transmit to the County Auditor of San Diego County a certified copy of this Ordinance, as no principal and interest is due on general obligation bonded indebtedness for the Fallbrook Public Utility District for the fiscal year 2007-08.

ARTICLE 25 ([Renumbered as Article 16 by Resolution 5006](#))  
Sec. 25.1, 25.2, 25.3, 25.4 & 25.5 – Rev. 7/93  
Sec. 25.2, 25.3, & 25.4 – Rev. 7/94, 7/95, 7/96, 7/97, 7/98, 7/99, 7/00, 7/01, 7/02, 7/03, 7/04, 7/05, 7/06, 7/07

**Article 2617.            Water Shortage Response Program.**

Sec. 2617.1            Declaration of Policy.

California Water Code Sections 375 et seq. permit public entities which supply water at retail to adopt and enforce a water conservation program to reduce the quantity of water used by the people therein for the purpose of conserving the water supplies of such public entity. The Board of Directors hereby establishes a comprehensive water conservation program pursuant to California Water Code Sections 375 et seq., based upon the need to conserve water supplies and to avoid or minimize the effects of any future shortage.

Sec. 2617.1.1 PSAWR Reduction Program.

The San Diego County Water Authority Permanent Special Agricultural Water Program (PSAWR) provides discounted wholesale supply and treatment pricing for qualified agricultural users within its service area on the basis that participants receive non-firm, interruptible supply up to the maximum allowed per the SDCWA Administrative Code. During periods of water shortages imposed by the Metropolitan Water District (MWD), the SDCWA, or due to emergency situations, those customers who are participating in the PSAWR shall abide by the conditions set forth by SDCWA. Administration of the PSAWR Program is incorporated by reference in Article 19 10 of this Administrative Code.

Sec. 2617.1.2 PSAWR Reduction Compliance.

When SDCWA imposes a mandatory use reduction, PSAWR customers must be prepared to reduce consumption by complying with a water allocation, or water use target. Water consumed during each billing period will be compared to the assigned target. Any use below the target will be accumulated and carried forward. The customer's cumulative use will be compared with the cumulative target, and any total usage above the target will be billed at the "above average" rates. This cumulative comparison will continue for the duration of the fiscal year. Below target usage "credits" will be carried forward until the cumulative target is exceeded, at which time, all cumulative "over target" use will be billed at the "above target" rates. The cumulative comparison process will start over in the next fiscal year.

Upon written request, customers shall reserve the right to "group" accounts and adjust, or "smooth", allocations to facilitate compliance.

Sec. 2617.2            Findings.

The Board of Directors finds and determines that a water shortage could exist as a result of a general regional water supply shortage due to increased demand or limited supplies.

The Board of Directors also finds and determines that the conditions prevailing in the coastal San Diego County area require that the water resources available be put to maximum beneficial use to the extent to which they are capable, and that the waste or unreasonable use, or unreasonable method of use, of water be prevented and that the conservation of such water encouraged with a view to the maximum reasonable and beneficial use thereof in the interests of the people of the Fallbrook Public Utility District and for the public welfare.

NORMAL CONDITIONS. The District's service area is in a semi-arid climate. Good water management practices dictate that water be used wisely and not wasted at any time. Customers are requested to follow the guidelines presented in Sec. ~~2617~~.8.1. Under Normal Conditions, the District will provide public education and outreach efforts to emphasize public awareness of the need to always voluntarily use water wisely and practice water conservation measures.

Sec. ~~2617~~.3            Application.

The provisions of this Administrative Code shall apply to all water served to persons, customers, and property by the Fallbrook Public Utility District.

Sec. ~~2617~~.4            Determination and Declaration by General Manager of Water Supply Conditions.

Based on information provided by the District's wholesale water agency of water availability supplies, the Fallbrook Public Utility District General Manager (or in the General Manager's absence his designee) is hereby authorized and directed to implement the provisions of this Administrative Code. Additionally, the General Manager (or in the General Manager's absence, his designee) is hereby authorized to make minor and limited exceptions to prevent undue hardship or unreasonable restrictions, provided that water shall not be wasted or used unreasonably and the purpose of this Administrative Code can be accomplished. Any such exceptions shall be reported to the Board of Directors at the next meeting.

The General Manager (or in the General Manager's absence his designee) shall from time to time based upon all available data determine and declare whether the District's water supply is in the following condition and post a notice thereof in the District's lobby and publish said notice in the local newspaper:

WATER SHORTAGE RESPONSE LEVEL 1 – WATER SHORTAGE WATCH CONDITION. This level applies when the San Diego County Water Authority notifies its member agencies that due to water shortage or other supply reductions, there is a reasonable probability there will be supply shortages and that a consumer demand reduction of up to 10 percent is required in order to ensure that sufficient supplies will be available to meet anticipated demands. The General Manager shall declare the existence of a Water Shortage Response Level 1 condition and take action to implement the Level 1 conservation practices identified in Sec. ~~2617~~.8.2. The District will suspend consideration of annexations to its service area.

The Board of Directors shall from time to time based upon all available data determine and declare whether the District's water supply is in one of the following conditions and post a notice thereof in the District's lobby and publish said notice in the local newspaper:

WATER SHORTAGE RESPONSE LEVEL 2 – WATER SHORTAGE ALERT CONDITION. This level applies when the San Diego County Water Authority notifies its member agencies that due to cutbacks caused by water shortages or other reduction in supplies, a consumer demand reduction of up to 20 percent is required in order to have sufficient supplies available to meet anticipated demands. The Board of Directors shall declare the existence of a Water Shortage Response Level 2 condition and implement the mandatory Level 2 conservation measures identified in Sec. ~~2617~~.8.3. The District will suspend consideration of annexations to its service.

WATER SHORTAGE RESPONSE LEVEL 3 – WATER SHORTAGE CRITICAL CONDITION. This level applies when the San Diego County Water Authority notifies its member agencies that due to increasing cutbacks caused by water shortages or other reduction of supplies, a consumer demand reduction of up to 40 percent is required in order to have sufficient supplies available to meet anticipated demands. The Board of Directors shall declare the existence of a Water Shortage Response Level 3 condition and implement the Level 3 conservation measures identified in Sec. ~~2617~~.8.4. The District will suspend consideration of annexations to its service area and no new potable water service shall be provided and no statements of immediate ability to serve or provide potable water service shall be issued.

WATER SHORTAGE RESPONSE LEVEL 4 – DROUGHT EMERGENCY CONDITION. This level applies when the San Diego County Water Authority Board of Directors declares a water shortage emergency pursuant to California Water Code Section 350 and notifies its member agencies that Level 4 requires a demand reduction of more than 40% in order for the District to have maximum supplies available to meet anticipated demands. The District shall declare a Water Shortage Emergency in the manner and on the grounds provided in California Water Code Section 350.

The General Manager is authorized to require submission of water use curtailment plans from those users having the largest effect on overall District consumption in order to protect the minimum supplies necessary to provide for public health, sanitation, and fire protection. Failure to provide curtailment plans in a timely manner or plans that do not meet the required cutbacks shall authorize the District to install flow restrictors at the meter or termination of service.

Sec. ~~2617~~.5                    Implementation of Emergency Water Management Program.

California Water Code Sections 375 et seq. permit public entities which supply water at retail to adopt and enforce a water conservation program to reduce the quantity of water used by the people therein for the purpose of conserving the water supplies of such public entity.

At such time when the Board of Directors of the District finds and determines that by reason of an anticipated general water supply shortage, inadequate San Diego County Water Authority distribution facilities, or the prospect of a major failure of the supply and distribution facilities of the Metropolitan Water District of Southern California exists, the Board may adopt and enforce a water conservation program to reduce the quantity of water used by the people therein for the purpose of conserving the water supplies of such public entity. Upon adoption of a water conservation program, the district shall provide notice to customers within (14) days of the Board's declaration of a water shortage. In addition, the Board may also find and determine that the conditions prevailing in the coastal San Diego county area require that the water resources available be put to maximum beneficial use to the extent to which they are capable, and that the waste or unreasonable use, or unreasonable method of use, of water be prevented and that the conservation of such water encouraged with a view to the maximum reasonable and beneficial use thereof in the interests of the people within the Fallbrook Public Utility District service area and for the public welfare.

The General Manager shall determine the extent of the emergency conservation required in order for the District to prudently plan for and supply water to its customers. Thereafter, the General Manager may order that the Emergency Water Management Program be implemented or terminated in accordance with the applicable provisions of this Article of the Administrative Code. The declaration of a water emergency shall be made by public

announcement and notice shall be published a minimum of three (3) consecutive times in a newspaper of general circulation and shall become effective immediately upon announcement.

The declaration shall be reported to the Board of Directors at its next regular meeting. The Board of Directors shall thereupon ratify the declaration or rescind the declaration, and may adopt such additional rules and regulations to limit water use during the emergency as it deems appropriate.

Sec. ~~26~~17.6 Duration of Declaration.

As soon as a particular condition is declared to exist, the water conservation measures provided for herein for that condition shall apply to all District water service until a different condition is declared.

Sec. ~~26~~17.7 Mandatory and Discretionary Use of Recycled Water.

Nothing in this Administrative Code shall prohibit or limit the use of recycled water for any purposes listed herein. No customer of the District shall make, cause, use or permit the use of potable water supplied by the District for construction grading on major subdivisions, paved surface cleaning, or greenbelt uses, including, but not limited to, cemeteries, playing fields, parks, and highway landscaped areas, when, following notice and a hearing, the District finds that recycled water is available under the following conditions:

1. The recycled water is of adequate quality and is available for use.
2. The recycled water may be furnished to such areas at a reasonable cost, equal to or less than the cost of supplying potable domestic water.
3. The State Department of Health Services has determined that such use would not be detrimental to public health.
4. The use of recycled water will not adversely affect downstream water rights, and will not degrade water quality.

Sec. ~~26~~17.8 Water Conservation Stages.

Sec. ~~26~~17.8.1 NORMAL CONDITIONS.

During Normal Conditions, customers are asked to use water wisely and to practice water conservation measures so that water is not wasted.

No water furnished by the District will be wasted. All water withdrawn from District facilities shall be put to reasonable beneficial use. District water users shall comply with the following water use prohibitions and conservation measures at all times:

1. Do not wash down paved surfaces, including but not limited to sidewalks, driveways, parking lots, tennis courts, or patios, except when it is necessary to alleviate safety or sanitation hazards.

2. Eliminate water waste resulting from inefficient landscape irrigation, such as runoff, low head drainage, or overspray, etc. Similarly, stop water flows onto non-targeted areas, such as adjacent property, non-irrigated areas, hardscapes, roadways, or structures.
3. Irrigate residential and commercial landscape before 10 a.m. and after 6 p.m. only.
4. Use a hand-held hose equipped with a positive shut-off nozzle or bucket to water landscaped areas, including trees and shrubs located on residential and commercial properties that are not irrigated by a landscape irrigation system.
5. Irrigate nursery and commercial grower's products before 10 a.m. and after 6 p.m. only. Watering is permitted at any time with a hand-held hose equipped with a positive shut-off nozzle, a bucket, or when a drip/micro-irrigation system/equipment is used. Irrigation of nursery propagation beds is permitted at any time. Watering of livestock is permitted at any time.
6. Use re-circulated water to operate ornamental fountains.
7. Wash vehicles using a bucket and a hand-held hose with positive shut-off nozzle, mobile high pressure/low volume wash system, or at a commercial site that re-circulates (reclaims) water on-site. Avoid washing during hot conditions when additional water is required due to evaporation.
8. The irrigation with potable water of ornamental turf on public street medians is prohibited.
9. The application of potable water to outdoor landscapes during or within 48 hours of measurable rainfall is prohibited
10. The irrigation with potable water of landscapes outside of newly constructed homes and buildings in a manner inconsistent with regulations or other requirements established by the County of San Diego's Landscape Ordinance.
11. Serve and refill water in restaurants and other food service establishments only upon request.
12. Offer guests in hotels, motels, and other commercial lodging establishments the option of not laundering towels and linens daily.
13. Repair all water leaks within five (5) days of notification by the Fallbrook Public Utility District unless other arrangements are made with the General Manager.
14. Use recycled or non-potable water for construction purposes when available.

Sec. 2617.8.2 WATER SHORTAGE RESPONSE LEVEL 1 – WATER SHORTAGE WATCH CONDITION.



During a Level 1 Water Shortage Watch condition, the District will increase its public education and outreach efforts to emphasize increased public awareness of the need to implement water conservation practices.

All persons using District water shall comply with Normal Conditions water conservation practices during a Level 1 Water Shortage Watch, as identified in Sec. ~~2617~~.8.1.

Upon declaration of a Level 1 Water Shortage Watch condition, the District will suspend consideration of annexations to its service area except under the following circumstances:

1. The applicant provides substantial evidence of an enforceable commitment that water demands for the project will be offset prior to the provision of a new water meter(s) to the satisfaction of Fallbrook Public Utility District.

Sec. ~~2617~~.8.3 WATER SHORTAGE RESPONSE LEVEL 2 – WATER SHORTAGE ALERT CONDITION.

During a Level 2 Water Shortage Alert condition, all persons using District water shall comply with Normal and Level 1 Water Shortage Watch water conservation practices during a Level 2 Water Shortage Alert, as identified in Sec. ~~2617~~.8.1 and ~~2617~~.8.2, and shall also comply with the following additional conservation measures:

1. During the months of June through October, limit residential and commercial landscape irrigation to no more than two (2) days per week on a schedule established by the General Manager and posted by the Fallbrook Public Utility District. During the months of November through May, landscape irrigation is limited to no more than once per week on a schedule established by the General Manager and posted by the Fallbrook Public Utility District. During extreme Santa Ana conditions (temperature > 80 and easterly winds > 20 mph), one additional day per week of watering is allowed. This section shall not apply to commercial growers or nurseries. This provision does not apply to landscape irrigation systems using water efficient devices, including but not limited to: weather based controllers, drip/micro-irrigation systems and stream rotor sprinklers.
2. Limit lawn watering and landscape irrigation using sprinklers to no more than ten (10) minutes per watering station per assigned day. This provision does not apply to landscape irrigation systems using water efficient devices, including but not limited to: weather based controllers, drip/micro-irrigation systems and stream rotor sprinklers.
3. Water landscaped areas, including trees and shrubs located on residential and commercial properties, and not irrigated by a landscape irrigation system governed by section 5 (b) (1), on the same schedule set forth in section 5 (b) (1) by using a bucket, hand-held hose with a positive shut-off nozzle, or low-volume non-spray irrigation.

4. Repair all leaks within seventy-two (72) hours of notification by the Fallbrook Public Utility District unless other arrangements are made with the General Manager.

For Levels 2 and above, the District may establish a water allocation for property served by the Fallbrook Public Utility District using a method that does not penalize persons for the implementation of conservation methods or the installation of water saving devices and allows for the banking and subsequent use of unused allocations.

If the District establishes a water allocation it shall provide notice of the allocation within (14) days of its establishment by including it in the regular billing statement for the fee or charge or by any other mailing to the address to which the District customarily mails the billing statement for fees or charges for ongoing water service. The following customer classes are subject to allocations: Commercial Agriculture (CA), Commercial Agriculture Domestic (CB), Commercial (C), Government (G), and Irrigation (I). Following the effective date of the water allocation as established by the District, any person that uses water in excess of the allocation shall be subject to a penalty in the amount of 1.5 times the Base Rate, for each unit of usage greater than the allocation. The penalty for excess water usage shall be cumulative to any other remedy or penalty that may be imposed for violation of this ordinance.

This provision shall not be construed to preclude the resetting or turn-on of meters to provide continuation of water service or to restore service that has been interrupted for a period of one year or less.

Sec. ~~2617~~.8.4 WATER SHORTAGE RESPONSE LEVEL 3 – WATER SHORTAGE CRITICAL CONDITION.

During a Level 3 Water Shortage Critical condition, all persons using District water shall comply with Normal, Level 1 Water Shortage Watch and Level 2 Water Shortage Alert water conservation practices during a Level 3 Water Shortage Critical condition and shall also comply with the following additional mandatory conservation measures:

1. During the months of June through October, limit residential and commercial landscape irrigation to no more than two (2) assigned days per week on a schedule established by the General Manager and posted by the Fallbrook Public Utility District. This section shall not apply to commercial growers or nurseries.
2. Water landscaped areas, including trees and shrubs located on residential and commercial properties, and not irrigated by a landscape irrigation system governed by section 6 (b) (1), on the same schedule set forth in section 6 (b) (1) by using a bucket, hand-held hose with a positive shut-off nozzle, or low-volume non-spray irrigation.
3. Stop filling or re-filling ornamental lakes or ponds, except to the extent needed to sustain aquatic life, provided that such animals are of significant value and have

been actively managed within the water feature prior to declaration of a drought response level under this ordinance.

4. Stop washing vehicles except at commercial carwashes that recirculate water, or by high pressure/low volume wash systems.
5. Repair all leaks within forty-eight (48) hours of notification by the Fallbrook Public Utility District unless other arrangements are made with the General Manager.

Sec. ~~2617~~.8.5 WATER SHORTAGE RESPONSE LEVEL 4 – WATER SHORTAGE EMERGENCY CONDITION.

During a Level 4 Water Shortage Emergency condition, all persons using District water shall comply with Normal, Level 1 Water Shortage Watch, Level 2 Water Shortage Alert, and Level 3 Water Shortage Critical water conservation practices during a Level 4 Water Shortage Emergency and shall also comply with the following additional mandatory conservation measures:

1. Stop all landscape irrigation, except crops and landscape products of commercial growers and nurseries. This restriction shall not apply to the following categories of use unless the Fallbrook Public Utility District has determined that recycled water is available and may be lawfully applied to the use.
  - A. Maintenance of trees and shrubs that are watered on the same schedule set forth in section 6 (b) (1) by using a bucket, hand-held hose with a positive shut-off nozzle, or low-volume non-spray irrigation;
  - B. Maintenance of existing landscaping necessary for fire protection as specified by the Fire Marshal of the local fire protection Fallbrook Public Utility District having jurisdiction over the property to be irrigated;
  - C. Maintenance of existing landscaping for erosion control;
  - D. Maintenance of plant materials identified to be rare or essential to the well being of rare animals;
  - E. Maintenance of landscaping within active public parks and playing fields, day care centers, school grounds, cemeteries, and golf course greens, provided that such irrigation does not exceed two (2) days per week according to the schedule established under section 6 (b) (1);
  - F. Watering of livestock; and
  - G. Public works projects and actively irrigated environmental mitigation projects.

2. Repair all water leaks within twenty-four (24) hours of notification by the Fallbrook Public Utility District unless other arrangements are made with the General Manager.

The District may establish a water allocation for property served by the District. If the District establishes a water allocation it shall provide notice of the allocation by including it in the regular billing statement for the fee or charge or by any other mailing to the address to which the District customarily mails the billing statement for fees or charges for ongoing water service. Following the effective date of the water allocation as established by the District, any person that uses water in excess of the allocation shall be subject to a penalty in the amount 1.5 times the Base Rate, for each unit of usage greater than the allocation. The penalty for excess water usage shall be cumulative to any other remedy or penalty that may be imposed for violation of this ordinance.

3. (PSAWR) customers as defined in the San Diego County Water Authority (SDCWA) Administrative Code must abide by any PSAWR restrictions that may be in place.

Water consumed during each billing period will be compared to the assigned target. Any use below the target will be accumulated and carried forward. The customer’s cumulative use will be compared with the cumulative target, and any total usage above the target will be billed at the “above target” rates. This cumulative comparison will continue for the duration of the fiscal year. Below target usage “credits” will be carried forward until the cumulative target is exceeded, at which time, all cumulative “over target” use will be billed at the “above target” rates and the cumulative comparison process will start over in the next fiscal year.

Sec. ~~2617~~.8.6 Drought Rates

Drought Rates would be implemented during declaration of Levels 1, 2, 3 and 4 described above. Drought Rates would only be in effect during declared drought Levels 1-4. The effective January 1, 2018, the Drought Rates during drought Levels 1-4 are set forth in the tables below:

<b>2018 Monthly Drought Rates by Drought Levels (\$/kgal)</b>			
<b>Customer Class (See Article <del>21</del> 12 for class definitions)</b>	<b>Level 1</b>	<b>Level 2</b>	<b>Level 3 and 4</b>
<b>Residential (D, LD,M)</b>			
Tier 1	\$5.91	\$6.16	\$6.92
Tier 2	\$6.00	\$6.26	\$7.03
Tier 3	\$7.30	\$7.62	\$8.56
<b>Ag. Domestic (AT)</b>			
Tier 1	\$5.91	\$6.16	\$6.92
Tier 2*	\$4.83	\$4.83	\$4.83
Tier 3*	\$4.17	\$4.17	\$4.17
<b>Commercial Domestic Ag. (CB)</b>			
Tier 1	\$5.91	\$6.16	\$6.92

Tier 2	\$5.08	\$5.30	\$5.95
<b>Agriculture TSAWR (AS)*</b>	\$4.17	\$4.17	\$4.17
<b>Commercial Ag (CB)</b>	\$5.08	\$5.30	\$5.95
<b>Commercial (C)</b>	\$6.08	\$6.35	\$7.13
<b>Irrigation Only (I)</b>	\$6.07	\$6.34	\$7.12
<b>Government (G)</b>	\$5.99	\$6.25	\$7.02

\*TSAWR customers must implement cuts to water use during drought restrictions or face penalties. Program compliance is discussed above in Section [2617.1.2](#).

Sec. [2617.9](#)                      Implementation of Conservation Levels.

The General Manager shall monitor the projected supply and demand for water by its customers on a daily basis. The General Manager shall determine the extent of the conservation required through the implementation and/or termination of particular conservation stages in order for the District to prudently plan for and supply water to its customers. Thereafter, the General Manager may order or recommend to the Board of Directors that the appropriate level of water conservation be implemented or terminated in accordance with the applicable provision of this Administrative Code. The declaration of any level beyond Water Shortage Response Level 1 shall be made by public announcement and notice shall be published a minimum of three (3) consecutive times in a newspaper of general circulation. The level designated shall become effective immediately upon announcement. The declaration of any level beyond Water Shortage Response Level 1 shall be by action of the Board of Directors.

Sec. [2617.10](#)                      Variances.

If, due to unique circumstances, a specific requirement of this Article of the Administrative Code would result in undue hardship to a person using District water or to property upon which the District water is used, that is disproportionate to the impacts to the District water users generally or to similar property or classes of water uses, then the person may apply for a variance to the requirements as provided in this section.

The variance may be granted or conditionally granted, only upon a written finding of the existence of facts demonstrating an undue hardship to a person using District water or to property upon with the District water is used, that is disproportionate to the impacts to the District water users generally or to similar property or classes of water use due to specific and unique circumstances of the user or the user’s property.

A completed appeal shall describe the specific reason(s) the allocation is causing undue hardship, including the following:

1. Commercial buildings that were empty or partially occupied during base period but are now occupied to a greater degree and require more water.
2. A grove with new trees planted a year before the base period began that, in the third year of growth, would need additional water.
3. Agricultural land used for annual crops that had abnormally low irrigation application during the base year.

4. An unexpected emergency line break, or equipment malfunction that has since been fixed.
5. Loss or reduction of an alternative water source, such as a well or pond.
6. Other, with a detailed description.

Sec. 2617.10.1 Application.

Application for a variance shall be a form prescribed by Fallbrook Public Utility District.

Sec. 2617.10.2 Supporting Documentation.

The application shall be accompanied by photographs, maps, drawings, and other information, including a written statement of the applicant.

Sec. 2617.10.3 Required Findings for Variance.

An application for a variance shall be denied unless the approving authority finds, based on the information provided in the application, supporting documents, or such additional information as may be requested, and on water use information for the property as shown by the records of the Fallbrook Public Utility District, all of the following:

- A. That the variance does not constitute a grant of special privilege inconsistent with the limitations upon other Fallbrook Public Utility District customers.
- B. That because of special circumstances applicable to the property or its use, the strict application of this ordinance would have a disproportionate impact on the property or use that exceeds the impacts to customers generally.
- C. That the authorizing of such variance will not be of substantial detriment to adjacent properties, and will not materially affect the ability of the Fallbrook Public Utility District to effectuate the purpose of this chapter and will not be detrimental to the public interest.
- D. That the condition or situation of the subject property or the intended use of the property for which the variance is sought is not common, recurrent or general in nature.

Sec. 2617.10.4. Approval Authority.

The General Manager or his/her designee shall exercise approval authority and act upon any completed application no later than 20 days after submittal and may approve, conditionally approve, or deny the variance. The applicant requesting the

variance shall be promptly notified in writing of any action taken. Unless specified otherwise at the time a variance is approved, the variance applies to the subject property during the term of the mandatory drought response.

Sec. ~~26~~17.10.5 Appeals to Fallbrook Public Utility District Board of Directors.

An applicant may appeal a decision or condition of the General Manager on a variance application to the Fallbrook Public Utility District Board of Directors within 10 days of the written decision upon written request for a hearing. The request shall state the grounds for the appeal. Any determination not appealed within ten (10) days is final. At a public meeting, the Fallbrook Public Utility District Board of Directors shall act as the approval authority and review the appeal de novo by following the regular variance procedure. The decision of the Fallbrook Public Utility District Board of Directors is final.

ARTICLE 26 (Renumbered as Article 17  
by Resolution 5006)

Sec. 26.6 – Rev. 7/97

Sec. 26.4, Sec. 26.5, Sec. 26.8.2 –  
Rev. 10/07

Article 26 revised in its entirety –  
6/08

Sec. 26.8.3, 26.9, 26.10 , 26.10.1,  
26.10.2, 26.10.3, 26.10.4, 26.10.5,  
and addition of Domestic Class and  
Multi-Unit Class rates– Rev. 6/09

Sec. 26.8.3 –Rev. 10/09

Sec. 26.8.3 – Rev. 5/11

Sec. 26.8.3 – Rev. 8/14

Sec. 26.11 – Rev 6/15

Secs. 26.1.1, 26.1.2, 26.4, 26.5,  
26.8.3, 26.8.5, 26.10, 26.10.1,  
26.10.4, 26.10.5, 26.11 – Rev. 3/16

Secs. 26.8.1, 26.8.3 – Rev. 6/16

Secs. 26.8.2, 26.8.3, 26.8.6 – Rev.  
12/17

Secs. 26.1.1, 26.1.2, 26.8.5 – Rev.  
12/20

## **Article 2718. Investment Policy**

### **Sec. 2718.1 General.**

The District's Investment Policy and practices of the District Treasurer are based on prudent money management principles and California Government Code, specifically Sections 53600 and 53630 et. seq.

**2718.1.1 Delegation of Authority.** The Board of Directors delegates the investment authority of the District to the Treasurer under the supervision of the General Manager. The Treasurer shall deposit money under the Treasurer's supervision and control in such institutions and upon such terms as the laws of the State of California and the Board of Directors may permit.

The Treasurer may delegate day-to-day investment decision making and execution authority to an investment advisor. Eligible investment advisors must be registered with the Securities and Exchange Commission (SEC) under the Investment Advisors Act of 1940. The advisor will follow the Policy and such other written instructions as are provided by the District.

**2718.1.2 Investment Objectives.** The practices of this District will always comply with the legal authority and limitations placed on it by the governing legislative bodies. The implementation of these laws, allowing for the dynamics of the money markets, will be the focus of this Investment Policy. When investing, reinvesting, purchasing, acquiring, exchanging, selling and managing public funds, the objectives of this District shall be:

1. The primary objective shall be to safeguard the principal of the funds under the Treasurer's control.
2. The secondary objective shall be to meet the liquidity needs of the District.
3. The third objective shall be to achieve a return on the funds under control of the Treasurer within the parameters of prudent risk management.

**2718.1.3 Prudent Investor Standard.** The Board of Directors, General Manager, and Treasurer adhere to the guidance provided by the "prudent investor standard," California Government Code (Section 53600.3), which obligates a fiduciary to insure that "When investing, reinvesting, purchasing, acquiring, exchanging, selling, or managing public funds, a trustee shall act with care, skill, prudence, and diligence under the circumstances then prevailing, including, but not limited to, the general economic conditions and the anticipated needs of the agency, that a prudent person acting in a like capacity and familiarity with those matters would use in the conduct of funds of a like character and with like aims, to safeguard the principal and maintain the liquidity needs of the agency. Within the limitations of this section and considering individual investments as part of an overall strategy, investments may be acquired as authorized by law."



Sec. 2718.2 Treasurer's Annual Statement of Investment Policy.

The following is the District's annual statement of investment policy rendered pursuant to Section 53646 (a) of the Government Code:

2718.2.1 Security of Principal Policy. The policy issues directed to protecting the District are:

- a) Limiting exposure to each type of security.
- b) Limiting exposure to each issue and issuer of debt.
- c) Determining the minimum credit requirement for each type of security at the time of purchase.

2718.2.2 Liquidity Policy. The policy issues directed to provide necessary liquidity are:

- a) Limiting the length of maturity for securities in the portfolio.
- b) Limiting exposure to illiquid securities.

2718.2.3 Return Policy. The policy issues directed to achieving a return are:

- a) Attaining a market rate of return taking into account the investment risk constraints and liquidity needs.
- b) Return is of least importance compared to the safety and liquidity policies described above.
- c) Majority of the investments shall be limited to low risk securities in anticipation of earning a fair return relative to the risk being taken.
- d) The performance of the portfolio shall be compared to an industry benchmark established by the Fiscal Policy and Insurance Committee and shall be reported quarterly. The Fiscal Policy and Insurance Committee shall review the performance benchmark on an annual basis to ensure that it remains appropriate for the District's investment objectives. The Fiscal Policy and Insurance Committee will bring any recommended changes to the industry benchmark to the Board for approval.

2718.2.4 Maturity Policy. The maximum maturity allowed by the California Government Code is five (5) years with shorter limitations specified for specific types of securities. However, the legislative body may grant express authority to make investments either specifically or as a part of an investment program approved by the legislative body that exceeds this five-year maturity limit. Such approval must be issued no less than three (3) months prior to the purchase of any security exceeding the five-year maturity limit.

2718.2.5 Prohibited Securities. The California Government Code does not authorize a local agency to invest in any of the following derivative notes:

- a) Inverse Floater
- b) Range Notes
- c) Interest-only strips derived from a pool of mortgages
- d) Any security that could result in zero interest accrual

Sec. 2718.3 Internal Controls.

The Treasurer is responsible for establishing and maintaining an internal control structure designed to ensure that the assets of the District are protected from loss, theft or misuse. The internal control structure shall be designed to provide reasonable assurance that these objectives are met. The concept of reasonable assurance recognizes that: 1) the cost of a control should not exceed benefits likely to be derived; and, 2) the valuation of costs and benefits requires estimates and judgments by management. Accordingly, the Treasurer shall establish a process for annual independent review by an external auditor to assure compliance with policies and procedures. The internal controls shall address the following points:

Control of Collusion: Collusion is a situation where two or more employees are working in conjunction to defraud their employer.

Separation of Transaction Authority from Accounting and Record Keeping: By separating the person who authorizes or performs the transaction from the person who records or otherwise accounts for the transaction, a separation of duties is achieved.

Custodial Safekeeping: Securities purchased from any bank or dealer including appropriate collateral (as defined by Government Code) shall be placed with an independent third party for custodial safekeeping.

Avoidance of Physical Delivery Securities: Book entry securities are much easier to transfer and account for since actual delivery of a document never takes place. Delivered securities must be properly safeguarded against loss or destruction. The potential for fraud and loss increases with physically delivered securities.

Clear Delegation of Authority to Subordinate Staff Members: Subordinate staff members must have a clear understanding of their authority and responsibilities to avoid improper actions. Clear delegation of authority also preserves the internal control structure that is contingent on the various staff positions and their respective responsibilities.

Written Confirmation of Telephone Transactions for Investments and/or Wire Transfers: Due to the potential for error and improprieties arising from telephone transactions, all telephone transactions should be supported by written communications and approved by the appropriate person. Written communications may be via fax if on letterhead and the safekeeping institution has a list of authorized signatures.

Development of a Wire Transfer Agreement with the Lead Bank or Third Party Custodian: This agreement should outline the various controls, security provisions, and delineate responsibilities of each party making and receiving wire transfers.

Sec. 2718.4 Permissible Investments.

Where this Policy specifies a percentage limitation for a particular security type, that percentage is applicable only on the date of purchase. Credit criteria listed in this Policy refers to the credit rating at the time the security is purchased. If an investment advisor is used and an investment's credit rating falls below the minimum rating required at the time of purchase, the investment advisor will immediately notify the Treasurer. The securities shall be reviewed and a plan of action shall be recommended by the Treasurer or investment advisor. The course of action to be followed will be decided on a case-by-case basis, considering such factors as the reason for the rate drop, prognosis for recovery or further drop, and market price of the security. The Fiscal Policy and Insurance Committee will be advised of the situation and intended course of action by e-mail or fax.

The District will limit investments in any one non-government issuer, except investment pools and money market funds, to no more than 5% regardless of security type.

Government Code 53601 addresses permissible investments. These investment categories are:

2718.4.1 Government Obligations. Two categories of Government Obligations, U.S. Treasury and Agency obligations may be invested. Both are issued at the federal level. U.S. Treasury obligations are United States Treasury notes, bonds, bills, or certificates of indebtedness, or those for which the faith and credit of the United States are pledged for the payment of principal and interest. Agency obligations are federal agency or United States government-sponsored enterprise obligations, participations, or other instruments, including those issued by or fully guaranteed as to principal and interest by federal agencies or United States government-sponsored enterprises..

Maximum Maturity: The maximum maturity of an issue shall be the current 5 year issue or an issue which at the time of the investment has a term remaining to maturity not in excess of five (5) years.

Maximum Exposure of Portfolio: The maximum exposure to the portfolio for this category is unlimited.

- 1) Treasury: Unlimited.
- 2) Agencies: Unlimited. No more than 75% of the portfolio value shall be invested in any single issuer.

Minimum Credit Requirement: None.

2718.4.2 Banker's Acceptance. This is a draft or bill of exchange, accepted by a bank or trust company and brokered to investors in a secondary market. The purpose of the banker's acceptance (BA) is to facilitate trade and provide liquidity to the import-export markets. Acceptances are collateralized by the pledge of documents such as invoices, trust receipts, and other documents evidencing ownership and insurance of the goods financed.

Maximum Maturity: The maximum maturity of an issue shall be 180 days.

Maximum Exposure of Portfolio: The maximum exposure to the portfolio for this category shall be 25%.

Minimum Credit Requirement: "A-1" or equivalent by a nationally recognized statistical rating organization (NRSRO)

2718.4.3 Commercial Paper. These are short-term, unsecured, promissory notes issued by firms in the open market. Commercial paper (CP) is generally backed by a bank credit facility, guarantee/bond of indemnity, or some other support agreement. The entity that issues the commercial paper must meet all of the following conditions in either paragraph a or paragraph b:

- a. The entity meets the following criteria: (i) is organized and operating in the United States as a general corporation, (ii) has total assets in excess of five hundred million dollars (\$500,000,000), and (iii) has debt other than commercial paper, if any, that is rated in a rating category of "A", the equivalent or higher by a NRSRO.
- b. The entity meets the following criteria: (i) is organized within the United States as a special purpose corporation, trust, or limited liability company, (ii) has program-wide credit enhancements including, but not limited to, over collateralization, letters of credit, or surety bond, and (iii) has commercial paper that is rated "A-1" or higher, or the equivalent, by a NRSRO.

Maximum Maturity: The maximum maturity of an issue shall be 270 days.

Maximum Exposure of Portfolio: The maximum exposure to the portfolio for this category shall be 25%. The District may purchase no more than 10% of the outstanding commercial paper of any single issuer.

Minimum Credit Requirements: "A-1", the equivalent or higher by a NRSRO.

2718.4.4 Medium-Term Notes. Corporate and depository institution debt securities issued by corporations organized and operating within the United States, or by depository institutions licensed by the U.S. (or any state) and operating within the U.S.

Maximum Maturity: The maximum maturity of an issue shall be 5 years.

Maximum Exposure of Portfolio: The maximum exposure to the portfolio for this category shall be 30%.

Minimum Credit Requirements: Rated in a rating category of “A”, the equivalent or higher by a NRSRO

**2718.4.5** Repurchase Agreements. A repurchase agreement (RP) consists of two simultaneous transactions. One is the purchase of securities by an investor (i.e., the District), the other is the commitment by the seller (i.e., a broker/dealer) to repurchase the securities at the same price, plus interest, at some mutually agreed future date.

Maximum Maturity: The maximum maturity of repurchase agreements shall be up to one year.

Maximum Exposure of Portfolio: The maximum exposure to the portfolio for this category shall be 10%.

Minimum Credit Requirements: None

**2718.4.6** Negotiable Certificates of Deposit. Certificates of deposit must be issued by a nationally or state-chartered bank, a savings association or a federal association (as defined by Section 5102 of the Financial code), a state or federal credit union, or by a federally licensed or state-licensed branch of a foreign bank.

Maximum Maturity: The maximum maturity of an issue shall be five (5) years.

Maximum Exposure to Portfolio: The maximum exposure to the portfolio for this category shall be 30%.

Minimum Credit Requirements: Rated in a rating category of “A”, the equivalent or higher for CDs issued with a long-term rating and “A-1” or higher for CDs issued with a short-term rating or their equivalents by a NRSRO.

**2718.4.7** State Local Agency Investment Fund (LAIF). There is no limit by law on the amount of funds that can be placed in this account. Interest is paid directly into the account by the State Local Agency Investment Fund.

**2718.4.8** San Diego County Treasurer’s Fund. There is no limit by law on the amount of funds that can be placed in this account. Interest is paid directly into the account by the County Treasurer.

**2718.4.9** Passbook and Money Market Savings Accounts. Savings accounts and/or money market accounts shall be maintained for monies that are needed on a day-to-day basis.

2718.4.10 State Obligations / State of California and Other States. Registered state warrants or treasury notes or bonds of this state, including bonds payable solely out of the revenues from a revenue-producing property owned, controlled or operated by the state or by a department, board, agency or authority of the state.

Registered treasury notes or bonds of any of the other 49 United States in addition to California, including bonds payable solely out of the revenues from a revenue-producing property owned, controlled, or operated by a state or by a department, board, agency, or authority of any of the other 49 United States, in addition to California.

Maximum Maturity: The maximum maturity of an issue shall be the current 5 year issue or an issue which at the time of the investment has a term remaining to maturity not in excess of five (5) years.

Maximum Exposure of Portfolio: The maximum exposure to the portfolio for 2718.4.10 and 2718.4.11-California Local Agency Obligations, category shall be a combined 25% of the book value of the investment portfolio. No more than 5% of the book value of the portfolio at the time of purchase may be invested in bonds issued by any one agency.

Minimum Credit Requirements: Rated in a rating category of “A”, the equivalent or higher for obligations issued with a long-term rating and “A-1” for obligations issued with a short-term rating or their equivalents by a NRSRO .

2718.4.11 California Local Agency Obligations. Bonds, notes warrants or other evidences of indebtedness of any local agency within California, including bonds payable solely out of the revenues from a revenue-producing property owned, controlled, or operated by the local agency, or by a department, board, agency, or authority of the local agency.

Maximum Maturity: The maximum maturity of an issue shall be the current 5 year issue or an issue which at the time of the investment has a term remaining to maturity not in excess of five (5) years.

Maximum Exposure of Portfolio: The maximum exposure to the portfolio for 2718.4.10 and 2718.4.11-California Local Agency Obligations, category shall be a combined 25% of the book value of the investment portfolio. No more than 5% of the book value of the portfolio at the time of purchase may be invested in bonds issued by any one agency.

Minimum Credit Requirements: Rated in a rating category of “A”, the equivalent or higher for obligations issued with a long-term rating and “A-1” for obligations issued with a short-term rating or their equivalents by a NRSRO.

2718.4.12 Joint Powers Authority Pool. The investment with a Joint Powers Authority Pool is mandated by that pool. To be eligible under this section, the joint powers authority issuing the shares shall have retained an investment adviser that meets all of the following criteria: (1) The adviser is registered or exempt from registration with the

Securities and Exchange Commission; (2) The adviser has not less than five years of experience investing in the securities and obligations authorized in subdivisions (a) to (q), inclusive; and (3) The adviser has assets under management in excess of five hundred million dollars (\$500,000,000).

Maximum Exposure of Portfolio: The maximum exposure to the portfolio for this category is unlimited.

Minimum Credit Requirement: None.

**2718.4.13** Money Market Mutual Funds.

Maximum Exposure of Portfolio: The maximum exposure to the portfolio for this category is 20%.

Minimum Credit Requirements: A mutual fund must receive the highest ranking by not less than two nationally recognized rating agencies or the fund must retain an investment advisor who is registered with the SEC (or exempt from registration), has assets under management in excess of \$500 million, and has at least five years experience investing in instruments authorized by Sections 53601 and 53635.

A money market mutual fund must receive the highest ranking by not less than two nationally recognized statistical rating organizations or retain an investment advisor registered with the SEC or exempt from registration and who has not less than five years experience investing in money market instruments with assets under management in excess of \$500 million.

**2718.4.14** Mortgage Pass-Through Securities and Asset-Backed Securities. A mortgage pass-through security, collateralized mortgage obligation, mortgage-backed or other pay-through bond, equipment lease-backed certificate, consumer receivable passthrough certificate, or consumer receivable-backed bond.

Maximum Maturity: The maximum maturity of an issue shall be the current 5 year issue or an issue which at the time of the investment has a term remaining to maturity not in excess of five (5) years.

Maximum Exposure of Portfolio: The maximum exposure to the portfolio for this category is 20%.

Minimum Credit Requirements: Rated in a rating category of “AA”, the equivalent or higher by a NRSRO.

**2718.4.15** Supranationals. United States dollar denominated senior unsecured unsubordinated obligations issued or unconditionally guaranteed by the International Bank for Reconstruction and Development, International Finance Corporation, or Inter-American Development Bank.

Maximum Maturity: The maximum maturity of an issue shall be the current 5 year issue or an issue which at the time of the investment has a term remaining to maturity not in excess of five (5) years.

Maximum Exposure of Portfolio: The maximum exposure to the portfolio for this category is 30%.

Minimum Credit Requirements: Rated in a rating category of “AA”, the equivalent or higher by a NRSRO.

Approval: Investments in supranational securities may only be made with prior approval of the Fiscal Policy and Insurance Committee.

Sec. [2718.5](#) Maturity/Limit of Investments.

With the exception of U.S. Treasury and Federal Agency securities, the maturity of a give investment will not exceed five (5) years, without prior board approval per Section [2718.2.4](#).

Sec. [2718.6](#) Reporting Requirements.

The Treasurer shall prepare a quarterly investment report to the Board of Directors that provides an overview of the District’s investments and lists the investment transactions for the period. The report shall also (1) state the compliance of the portfolio with the statement of investment policy, or the manner in which the portfolio is not in compliance, and (2) the report shall include a statement denoting the ability of the District to meet its expenditure requirements for the next six months, or provide an explanation as to why sufficient money shall, or may, not be available. The Treasurer shall also provide the Board a summary report of investments on a monthly basis.

A subsidiary ledger of investments may be used in the report in accordance with accepted accounting practices.

In the event that an investment originally purchased within policy guidelines is downgraded by any one of the credit rating agencies, the Treasurer shall report it at the next regular scheduled meeting of the Board.



**ARTICLE 27** (Renumbered as Article  
18 by Resolution 5006)

Revised in its entirety: 2/94  
Adopted in current form: 1/96,  
1/97, 1/98, 1/99  
Sec. 27.2.4 – Rev. 1/00  
Adopted in current form: 1/01  
Sec. 27.4.7 – Rev. 10/01  
Sec. 27.6 – Rev. 1/03  
Sec. 27.2.4 – Rev. 1/07  
Sec. 27.4.4 – Rev. 3/07  
Secs. 27.2.3, 27.4.1(2), 27.4.2,  
27.4.3, 27.4.4, & 27.4.6 – Rev. 9/07  
Sec. 27.2.1 – Rev. 1/10  
Secs. 27.4.10-12 – Rev. 1/12  
Secs. 27.2.4, 27.2.5, 27.4.5, 27.4.6,  
27.4.7, 27.4.10, 27.4.11, 27.4.13,  
27.4.14, 27.5 – Rev. 2/13  
Secs. 27.4.6, 27.4.11 – Rev. 1/14  
Secs. 27.1, 27.1.1, Attachment A –  
Rev. 3/15  
Secs. 27.1, 27.1.1, 27.1.2, 27.1.3,  
27.2, 27.2.3, 27.2.4, 27.3, 27.4,  
27.4.1, 27.4.2, 27.4.3, 27.4.4,  
27.4.6, 27.4.10, 27.4.11, 27.4.12,  
27.4.13, 27.4.14, 27.4.15, 27.5 –  
Rev. 2/16  
Secs. 27.2.4, 27.4, 27.4.3, 27.4.4,  
27.4.6, 27.4.10, 27.4.11, 27.4.14,  
27.4.15 – Rev. 3/17  
Sec. 27.2.3 – Rev. 6/18  
Sec. 27.6 – Rev. 7/18  
Sec. 27.4.14 – Rev. 2/19

## **Article 2819. Recycled Water Program**

### **Sec. 2819.1 Declaration of Policy.**

- a. The Fallbrook Public Utility District (FPUD) operates and maintains a recycled water distribution system within its service area enabling it to provide disinfected tertiary treated recycled water for a variety of beneficial uses. The District shall require the use of recycled water in-lieu of potable water for irrigation or other non-potable uses where recycled water is suitable and available.
- b. The beneficial use of recycled water is regulated by the California State Water Resources Control Board (SWRCB). California Water Code Section 13551 establishes a State policy to encourage the use of recycled water.
- c. FPUD shall determine whether a potential service will be furnished with recycled water and/or potable water. The feasibility of recycled water service will be considered on a case-by-case basis and in accordance with applicable law.

### **Sec. 2819.2 Statutory Requirements.**

- a. All onsite and public recycled water facilities must be consistent with and adhere to the requirements described in the following documents:
  1. FPUD Backflow and Cross-Connection Control Ordinance, Article ~~19~~ 10.22
  2. FPUD Recycled Water Program, Article 2819
  3. California Code of Regulations, Title 22, Division 4
  4. California Code of Regulations, Title 17, Division 1, Chapter 5, Subchapter 1, Group 4, Articles 1 and 2
  5. San Diego County Department of Environmental Health Recycled Water Program Requirements
  6. For Facilities Hauling Recycled Water: Engineering Report for the Installation of Hauled Recycled Water Fill Stations and Use of Hauled Recycled Water in the San Diego Region, San Diego County Water Authority, July 8, 2015
  7. All applicable Federal, State or local statutes, regulations and ordinances

### **Sec. 2819.3 Approved Use.**

- a. These rules and regulations pertain to recycled water service to lands and/or improvements lying within the legal boundaries of the District unless otherwise stated. It is the intent of the District to provide recycled water service in accordance with these rules and regulations to all areas that recycled service is feasible. The District will work with existing potable water users to facilitate the conversion of existing facilities for recycled water use or the installation of facilities for a new recycled water use. All new developments will be evaluated for the feasibility of recycled water usage.

- b. The uses of recycled water include only those uses approved by the District, local and State regulatory authorities and for which Title 22, California Code of Regulations provides treatment requirements. All potential applications of recycled water shall be reviewed and approved by the District prior to installation of facilities. Prior to approval and at its discretion, the District may set forth specific requirements as conditions for providing service and/or require specific prior approval from the appropriate regulatory agencies.
- c. The facilities shall be constructed in accordance with the procedures and requirements of the District. No recycled water mains or connections to the recycled water mains shall be installed unless shown on approved drawings and approved by the District.

Sec. ~~2819~~.4 Definitions.

- b. Approved Backflow Prevention Assemblies.

A device/assembly approved by the State of California and the District which is installed to protect the potable water supply from contamination through backflow of a non-potable substance.

- c. Artificial Lake.

A man-made lake, pond, lagoon, or other body of water that is used wholly or partly for landscape, scenic or non-contact recreational purposes.

- d. Board.

The duly elected and constituted Board of Directors of the Fallbrook Public Utility District.

- e. Cross-Connection.

Any unprotected actual or potential connection between any part of a water system used or intended to supply potable water and any source or system containing recycled or other water or substance that is not potable and not acceptable for human consumption.

- f. Cross-Connection Control Specialist.

An individual who has a current American Water Works Association and/or American Backflow Prevention Association Specialist Certificate on file with the District

- g. Designated User.

A recipient of recycled water service from the District.

- h. District.

The Fallbrook Public Utility District, a duly constituted Public Agency of the State of California and located in San Diego County, California.

i. Greenbelt Areas.

Greenbelt areas include, but are not limited to, golf courses, playing fields, cemeteries, parks, and landscaping.

j. Hauled Recycled Water.

Recycled water use that complies with the San Diego County Water Authority publication “Engineering Report for the Installation of Hauled Recycled Water Fill Stations and Use of Hauled Recycled Water in the San Diego Region.”

k. Industrial Process Water.

Water used by any industrial facility with process water requirements which includes, but is not limited to, rinsing, washing, cooling and construction.

l. Manager.

The duly appointed General Manager of the Fallbrook Public Utility District or their designee.

m. Non-Potable Water.

Water, which does not conform to federal, state and local standards for human consumption.

n. Non-Potable Water Distribution System.

A piping system intended for the delivery of non-potable water only, and which is maintained separate from any potable water distribution system.

o. Non-Potable Water Transmission Mains.

A piping system intended for the delivery of non-potable water only and which is maintained separate from any potable water distribution system and which is owned by the District.

p. Non-Potable Water Use Area.

The property or portion of property, which has been approved by the District for non-potable or recycled water service.

q. Notice of Determination.

The notice provided to a designated user by the District.

r. Off-Site Facilities.

Those facilities located off the user’s site and under the control of the District, including the service meter and any backflow prevention assembly (ies) installed with the meter.

s. On-Site Facilities.

Facilities under the control of the customer beginning at the water meter and backflow prevention assembly if installed.

t. Potable Water.

Water furnished to the customer that is approved for human consumption and conforms to all federal, state and local requirements.

u. Recycled Water.

Water which as a result of filtration and disinfection of domestic wastewater is suitable for a direct beneficial use or a controlled use that otherwise would not occur.

v. Recycled Water Facilities.

Facilities used in the storage, pumping and conveyance of recycled water.

w. Recycled Water Service Connection.

The point of connection of the customer's recycled water line with the recycled water service main of the District which shall normally be the downstream end of the recycled water meter tailpiece.

x. Site Supervisor.

An individual who has taken a training course, normally four hours in length, that has been approved by State and local authorities and the District for the on-site use of recycled water.

Sec. 2819.5 Administration.

a. Manager.

The District General Manager shall administer, implement, and enforce the provisions of this Article of the Administrative Code. Any duties imposed upon the General Manager may be delegated by him to persons in the employ of the District.

b. Recycled Water Master Plan.

The General Manager shall prepare and update a Recycled Water Master Plan. The Plan shall include, but not be limited to, actual and future planning for recycled water use.

c. Coordination among Agencies.

The District shall examine the potential for initiating a coordinated effort between the District and other public agencies. The purpose of this effort shall be to share in the production and utilization of recycled water.

d. Fees and Charges.

All fees and charges for the use of recycled water shall be established separately by the Board in Article 21 of the Administrative Code.

e. Payment for On-Site Facilities.

The Designated User shall pay for all on-site facilities, including backflow prevention assemblies that may be necessary to protect the health and safety of on-site residents or employees. The Designated User of recycled water shall comply with all requirements of applicable federal, state, and local statutes, ordinances and regulations. The cost of any investigations by District staff and/or regulatory authorities resulting from the misuse of recycled water shall be the responsibility of the Designated User.

Sec. 2819.6 Suspension or Termination of User Service.

2819.6.1 Recycled water service may be suspended or terminated at any time by the Manager. Reasons for suspension or termination shall include, but not be limited to, the following:

1. Failure by a Designated User to adhere to the provisions of this Article.
2. The lack of necessary procedures or facilities for protection of health, safety and welfare.
3. The discovery of a cross-connection between the on-site potable and non-potable water distribution system.
4. Changes in the use and/or footprint of the non-potable distribution system without District approval.
5. Recycled water service may also be subject to discontinuation of service for failure to pay any rates, fees and charges due to the DISTRICT in accordance with the DISTRICT's discontinuation procedures then in effect for non-residential service.

2819.6.2 Procedure.

The suspension or termination procedure shall be as follows: Where the District determines that service should be suspended or terminated, a written notice shall be mailed by regular mail to the customer at least ten (10) calendar days prior to the date of proposed suspension or termination of services. This notice shall set forth the reasons for the suspension or termination of services. In the event the District determines an emergency condition prevails at the time the written notice of proposed suspension or termination is mailed to the customer, the District may immediately suspend recycled water service pending a determination of any appeal. If an emergency condition does not exist, the user shall have ten (10) calendar days to come into compliance with the written notice. Thereafter the District may commence suspension or termination procedures.

2819.6.3 Appeals of the Suspension or Termination Notice.

The customer may appeal the determination of the District as follows:

Not later than ten (10) calendar days following the date upon which the District Manager forwards to the customer a Notice of Suspension or Termination the customer may appeal to the Board of Directors by submitting a written appeal to the Board Secretary.

The Board of Directors shall conduct a hearing concerning the proposed determination within thirty (30) calendar days of receipt of this written appeal. Within a reasonable time thereafter the Board of Directors shall render a decision which shall be final.

2819.6.4                      Prohibited Connections.

No person shall make any connection to the recycled water facilities of the District unless the District has executed a written Agreement with said person as Designated User of recycled water service in accordance with the provisions of the Article of the Administrative Code.

2819.7                      Implementation.

2819.7.1                      Designation of Users.

The intent of the District is to work cooperatively with users to facilitate the conversion of existing potable users or the installation of new recycled services. The District would execute a User Agreement with the potential Designated User to implement the provisions of this Article of the Administrative Code.

If the potential Designated User declines to voluntarily execute a User Agreement with the District, but the District determines that the potential Designated User would be a beneficial user of suitable and available recycled water supplies, the District may issue a Notice of Determination that a specific water user shall be a Designated User of recycled water. A general description of the obligations of the potential Designated User shall accompany this notification. A proposed schedule for implementation of the use of recycled water shall be included in this Notice.

2819.7.2                      Appeal.

The potential Designated User may file a Notice of Appeal with the District within thirty (30) calendar days after the Notice of Determination has been sent. Upon receipt of the Notice of Appeal the District Manager shall schedule a hearing of the appeal before the Board of Directors and provide notice in accordance with the rules of the District.

Following this hearing, the determination of the Board shall be final and binding.

2819.7.3                      Design and Construction of On-Site Facilities.

The Designated User shall provide and install, at no cost to the District, all on-site recycled water facilities. Recycled water facilities shall conform to State and local

statutes, ordinances, regulations and District requirements. The Designated User shall make, at no cost to the District, any modifications to the potable water system on the premises which are required by the District in order to permit the safe use of recycled water service. Such facilities shall include, but not be limited to, installation of approved backflow prevention assemblies. Specifications and record drawings of on-site recycled facilities shall be prepared and be available for inspection or use on the premises of the Designated User and at the District office.

**2819.7.4**                      Recycled Water Supervisor.

The Designated User shall designate a Site Supervisor and shall keep the District informed of the Site Supervisor's identity. The Site Supervisor shall have attended a Site Supervisor training class, be knowledgeable in the construction and operation of the recycled water system and any on-site uses of recycled water. The Site Supervisor should be familiar with federal, State and local guidelines, criteria, standards, rules and regulations governing the use of recycled water. The Site Supervisor shall be responsible for overseeing the recycled water service and maintaining the on-site facilities in conformance with the District's guidelines and regulations. The Site Supervisor shall be responsible for the prevention of any cross-connections between the recycled water system and the on-site potable system. Any actual or suspected cross-connections shall immediately be reported to the District.

**2819.7.5**                      Conversion of Existing Facilities.

Where a Designated User proposes a conversion of any existing potable water system to a recycled water system, a comprehensive investigation of the system including conversion plans shall be performed at the expense of the Designated User. The District shall review and approve the conversion plans before the potable system is converted to recycled water use.

**2819.7.6**                      User Agreement Form.

Upon the final determination by the District that a property, or a portion of the property, shall be served with recycled water the Designated User shall execute a User Agreement with the District to implement the provisions of this Article of the Administrative Code. The District shall provide a general form of the agreement. The District may refuse or terminate recycled water service if a signed User Agreement is not on file with the District.

**2819.8**                      Water Meter Requirement.

All recycled water used on any premises approved for recycled water service must be metered. The District shall be responsible for the enforcement of this requirement.

When a parcel is developed, if the parcel has the potential for future recycled use or is along a planned recycled line extension, the development must provide for facilities to utilize recycled water when available or pipeline extensions through the parcel at the time of project construction.



2819.9                    Public Safety Requirements.

2819.9.1                    General Requirements.

All sites shall comply with the County of San Diego’s Department of Environmental Health Recycled Water Plan Checklist and Inspection Manual and all District rules and regulations for recycled water service.

2819.9.2                    Backflow Protection at the Service Meter.

All recycled water sites are required to prevent backflow into the public water supply. Backflow protection will be determined by the degree of hazard present on the Designated User’s property. Sites that use recycled water for irrigation purposes as part of a dual plumbed system are required to install a double check valve assembly device on the potable water service connection. Recycled water sites that also use potable water must install a reduced pressure principle backflow prevention assembly at the potable water connection.

2819.10                    Truck Load Delivery of Recycled Water.

The San Diego County Water Authority publication “Engineering Report for the Installation of Hauled Recycled Water Fill Stations and Use of Hauled Recycled Water in the San Diego Region” shall be complied with by any user that has been certified by the District for hauling of recycled water.

2819.11                    Miscellaneous.

If any section, subsection, sentence, clause or phrase of the Article of the Administrative Code is for any reason held to be unconstitutional or invalid, such decision shall not affect the validity of the remaining portions of this Article of the Administrative Code. The Board of Directors hereby declares that it would have passed each section, subsection, sentence, clause or phrase thereof irrespective of the fact that any one or more sections, subsections, or sentences, clauses or phrases may be unconstitutional or invalid.

2819.12                    Non-Liability.

The District will not be responsible or liable for any suspension in service of, or failure to supply, recycled water, or for any damage or injury to person or property relating to the provision of recycled water.

<b>ARTICLE 28</b> <u>(Renumbered as Article 19 by Resolution 5006)</u> Program Adopted 2/94 Sec. 28.9 – Rev. 6/95 Sec. 28.1-28.4, 28.6, 28.9, 28.10 – Rev. 7/97 All Sections – Rev. 1/16 All Sections – Rev. 1/21
--

**Article 29 20. Emergency Action Plan (EAP)**

The Fallbrook Public Utility District has adopted an Emergency Action Plan for internal use by its officers, employees and Directors. The plan sets guidelines to use when an emergency arises.

The District's Emergency Action Plan (EAP) is made a part of this Administrative Code and incorporated into the District's Injury/Illness Prevention Program (IIPP).

**ARTICLE 29**  
**(Renumbered as Article**  
**20 by Resolution 5006)**  
  
Program Adopted 6/94  
Rev. 2/20

## **FALLBROOK PUBLIC UTILITY DISTRICT EMERGENCY ACTION PLAN (EAP)**

All employees will follow the guidelines below when an emergency arises. All employees will be required to participate in all "training elements."

- 1) The Operations Manager (or designee) will be the individual responsible for coordinating the Emergency Response Plan. His responsibilities include, but are not limited to:
  - A. Assessing the situation to determine if an emergency exists that requires activating the District Emergency Action Plan.
  - B. Directing all efforts in the area, including evacuating personnel and minimizing property loss.
  - C. Ensuring that outside agencies are called when necessary.
  - D. Directing shutdown of operations, when necessary.
  - E. Direct the Emergency Response Team.
  
- 2) If a major emergency involving fire or threat of an explosion occurs, and evacuation of the building and/or yard is necessary, the following will be done:
  - A. The Receptionist will alert all employees by way of the intercom system that there is an emergency and that all employees will evacuate to the announced designated meeting area.
  - B. The Operations Manager will establish his "command post" next to where the employees are to be evacuated.
  - C. Alternate communications can be the District's cellular phone, radio system (high band and low band), and coordination with the Sanitary District's base station with our radio system.
  - D. Regular updating of off-duty emergency on-call personnel will help keep the answering service current on who to notify during off-hours.
  
- 3) The Operations Manager (or designee) will be responsible to account for all personnel and notify authorities if anyone is believed missing. No personnel shall leave the scene until a total head count has been conducted (unless it is not safe to remain). Do not leave this area until the Operations Manager (or designee) or your supervisor knows you are leaving.
  
- 4) The Emergency Response Team (ERT) has to be able to distinguish between an emergency that they can handle and one that needs professional emergency aid. The emergency response team will be trained in the following:
  - A. Use of various types of fire extinguishers;
  - B. First Aid and CPR;
  - C. Shutdown procedures including all electric panels, gas main and location of the shut off devices;
  - D. Evacuation procedures;
  - E. Use of breathing apparatus (when applicable);
  - F. Search and rescue procedures (if there is a major disaster).

5) The Emergency Response Team members are:

- A. Operations Manager,
- B. Field Service Manager,
- C. All Department Supervisors,
- D. Safety & Risk Officer.

6) Employee Accountability Procedures after Evacuations:

- A. When an evacuation signal is given, each supervisor involved will assume a station in the vicinity of the designated evacuation area. Supervisor will insure all personnel are evacuated and will provide assistance to employees requiring same.
- B. All employees will proceed to a designated evacuation area for a head count by their supervisor. Supervisors will then report their department's status to Safety or designee. No one is to re-enter the building or yard for any reason until the Fire Department or other responsible agency has notified the District the building or yard is safe for re-entry

---

## BUILDING EVACUATION

---

### IN THE OFFICE OR YARD:

- 1) Each employee is to be aware of all marked exits from the area and building.
- 2) When evacuating the building, do not collect your personal belongings (purse, brief case, etc.) leave by walking quickly to the nearest marked exit and ask others to do the same. DO NOT RUN.
- 3) Assist all customers and the handicapped in exiting the building.
- 4) When outside, proceed to the announced designated meeting area. Keep well away from the building and keep clear of emergency vehicles. Do not leave this area until the Operations Manager or your supervisor knows you are leaving.
- 5) Supervisors, to the best of their ability, and without re-entering the building, will report to the Operations Manager if everyone has evacuated the area safely.
- 6) Do not return to the building until being told it is OK to do so by the Fire Dept. or Police.

---

## FIRE

---

### IN THE OFFICE OR YARD:

- 1) Know the location of fire extinguishers in your area and know how to use them.
- 2) In case of fire, immediately call 911. Give your name and describe the location and size of the fire.
- 3) On a minor fire that appears to be controllable, promptly direct the charge of a fire extinguisher toward the base of the flame. Get help if necessary.
- 4) On large fires that are not immediately controllable, promptly or after using the extinguisher, close all doors to confine the fire and reduce the oxygen - but do not lock doors.
- 5) Notify the receptionist to alert employees and instruct them to evacuate the building by quickly walking to the nearest exit, (being sure to collect your personal belongings, purse, brief case, etc.) and alerting people as you go.
- 6) Once outside, move to the announced designated meeting area, and stay well away from the building. Do not leave this area until the Operations Manager or your supervisor knows you are leaving. Keep clear of emergency vehicles.
- 7) Do not return to the building until being told it is OK to do so by the Fire Dept. or Police.

### IN THE FIELD:

- 1) Notify the office, by radio, to report the fire to the fire department. Be sure to describe the location, type of fire and the area involved.
- 2) On a minor fire that appears to be controllable, promptly direct the charge of a fire extinguisher toward the base of the flame.
- 3) If in a remote area, coordinate to meet the Fire Dept. at a predetermined location to direct them to the area.

---

## VIOLENCE OR CRIMINAL BEHAVIOR

---

### IN THE OFFICE OR DISTRICT YARD:

Assist in making the Facility a safe place by being alert to suspicious situations.

- 1) If you witness any suspicious situations do not hesitate, CALL 911 and then, if safe, alert your supervisor or Operations Manager of the situation.
- 2) If you are the victim; or are involved in any on property violation of the law; or witness an on-property violation of the law, such as assault, robbery, theft, overt sexual behavior, etc., DO NOT TAKE ANY UNNECESSARY CHANCES. Notify your supervisor and call 911 and report the following:
  - a. Nature of incident.
  - b. Building location of incident.
  - c. Description of person(s) involved.
  - d. Description of property involved.
- 3) Assist the sheriff when they arrive by supplying them with additional information and ask others to do the same.
- 4) Report to your supervisor the existence of any person loitering or soliciting on District property. These people may be asked to leave if they do not have permission or a proper reason for being on the property. The Sheriff's Dept. is to be called if they refuse to leave when asked.

### IN THE FIELD:

- 1) Do not confront any trespasser(s) on District property.
- 2) If trespassers are observed stay at a safe distance and;
  - a. Report to the Operations Manager, by radio, the area and what activity is going on.
  - b. The Operations Manager will notify the Sheriff's Office who will respond to the area.

---

## EXPLOSION – AIRPLANE CRASH OR SIMILAR

---

### IN THE OFFICE OR YARD:

- 1) Immediately take cover under tables, desks and any other such objects, which will give you protection against glass or debris.
- 2) After the effects of the explosion have subsided, call 911. Give your name; describe the location and nature of the emergency.
- 3) Evacuate the building being sure to collect your personal belongings (purse, brief case, etc.) and:
  - a. Be aware of any structural damage.
  - b. Stay away from glass doors and windows.
  - c. Do not touch or move any suspicious objects.
- 4) Assist others, especially the injured and handicapped in the evacuation of the building.
- 5) Once outside, move to the announced designated meeting area, away from the affected area. Keep clear of emergency vehicles. Do not leave this area until the Operations Manager or your supervisor knows you are leaving.
- 6) To the best of your ability, and without re-entering the building, determine if everyone has evacuated safely.
- 7) Do not return to the building until being told it is OK to do so by the Fire Dept. or Police.

### IN THE FIELD:

- 1) Notify the office by radio, cell phone, or other means the location, the extent of the incident, and what assistance you need.
- 2) Do not touch or move any suspicious objects.
- 3) Keep a safe distance until emergency help arrives.



---

## EARTHQUAKE

---

### IN THE OFFICE OR YARD:

- 1) During an earthquake remain calm and quickly follow the steps outlined below.
- 2) If indoors, seek refuge in a doorway or under a desk or table. Stay away from glass windows shelves and anything else that might fall.
- 3) If outdoors, move quickly away from buildings, utility poles and other structures.
- 4) After the initial shock, evaluate the situation and if emergency help is necessary, call 911. Protect yourself at all times and be prepared for aftershocks.
- 5) Coordinate with management and begin turning off all potentially hazardous equipment such as gas and electric appliances. Damaged facilities should be reported.
- 6) Evacuate the building by quickly walking to the nearest exit, alerting people as you go. Be aware of structural damage and assist both the handicapped and injured. DO NOT RUN.
- 7) Once outside, move to the announced designated meeting area away from the building. Keep clear of emergency vehicles. Do not leave this area until the Operations Manager or your supervisor knows you are leaving.
- 8) Do not return to the building until told to do so by police and fire personnel.

### IN THE FIELD:

- 1) Pull over to the side of the road, away from possible falling objects like power lines, telephone poles, trees, buildings, etc. and stay in your vehicle.
- 2) Report to the main office as soon as it is safe to travel. If it is not safe to travel, contact the office or another unit by radio informing them of your location and situation.

**SUBJECT: EMERGENCY NOTIFICATION PROCEDURE OF AMMONIA RELEASE,  
WATER DEPARTMENT**

Ammonia stations are equipped with a Telemetry Alarm System that when activated will page the “on-call” System Operator. If there is no response with 30 minutes, the Operation Manager will then be called.

**REGULAR WORKING HOURS (7:00 AM TO 4:30 PM):**

Fallbrook Service Area:	Cellular Phone #
Standby System Operator	760-497-4096

**AFTER HOURS, WEEKENDS AND HOLIDAYS:** Incoming calls to the District's answering service (760728-1125) will be given to the water department on-call duty person who will be responsible for notifying the following personnel.

Name	Cellular Phone #
Standby System Operator	760-497-4096
Water System Supervisor	760-497-5777
Operations Manager	760-497-4103

**Article 3221. Records Retention and Destruction Policy**

Sec. 3221.1 Purpose.

The purpose of this policy is to provide guidelines to staff regarding the retention or disposal of District records; provide for the identification, maintenance, safeguarding and disposal of records in the normal course of business; ensure prompt and accurate retrieval of records; and ensure compliance with legal and regulatory requirements.

Sec. 3221.2 Authorization to Implement Policy.

The General Manager is authorized by the Board of Directors to interpret and implement this policy, and to cause to be destroyed any or all such records, papers and documents that meet the qualifications governing the retention and disposal of records, as specified below.

Sec. 3221.3 Government Code (Chapter 7) Sections Providing for the Destruction of Records of Special Districts:

60200. Duplicate records, papers, or documents. The retention and disposal of records by the Fallbrook Public Utility District, the legislative body of any special district may authorize at any time the destruction or disposition of any duplicate record, paper, or document, the original or a permanent photographic record of which is in the file of any officer of a department of the District.

60201. Records, papers or documents more than two years old and prepared or received other than pursuant to statute. The legislative body of a district may authorize the destruction or disposition of any record, paper, or document which is more than two years old and which was received in any manner other than pursuant to state statute. Such records, papers, or documents need not be photographed, reproduced, or microfilmed prior to destruction and no copy thereof need be retained.

60202. Unaccepted bids for construction of public works more than two years old. The legislative body of a district may authorize the destruction of any unaccepted bid or proposal for the construction or installation of any building, structure or other public work, which is more than two years old.

60203. Records, papers, or documents not required to be filed: Conditions. The legislative body of a district may authorize the destruction of any record, paper, or document that is not expressly required by law to be filed and preserved if all of the following conditions are complied with:

- a. The record, paper, or document is photographed, microphotographed, or reproduced by electronically recorded video images on magnetic surfaces, recorded in the electronic data processing system, recorded on optical disk, or any other medium which does not permit additions, deletions, or changes to the original document in compliance with the minimum standards or guidelines, or both, as recommended by the American National Standards Institute or the Association for Information and Image Management for recording of permanent records or non-permanent records, whichever applies;

- b. The device used to reproduce the record, paper, or document on film optical disk or any other medium is one which accurately reproduces the original thereof in all details, and which does not permit additions, deletions, or changes to the original document images;
- c. The photographs, microphotographs, or other reproductions on film or any other medium are placed in conveniently accessible files and provision is made for preserving, examining, and using the files.

For the purpose of this section, every reproduction shall be deemed to be an original record and a transcript, exemplification, or certified copy, as the case may be, of the original.

Sec. ~~321~~.4 State Controller's Guidelines.

The basic guidelines for destruction of records of special districts is in Government Code Sections 60200 through 60203 recorded above. The following is supplementary information and intends to define an acceptable records retention and destruction guide for special districts.

- A. Accounting Records. Include but are not limited to the following:
  - 1. Source Documents
    - a) Invoices
    - b) Purchase Orders
    - c) Deposit Permits
    - d) Warrants
    - e) Vouchers
    - f) Requisitions
    - g) Receipts
    - h) Claims
    - i) Bank Statements
    - j) Bank Deposits
    - k) Checks
    - l) Bills
    - m) Various accounting authorizations taken from Board minutes, resolutions, or contracts.
  - 2. Journals
    - a) Cash Receipts or Disbursement Book
    - b) Note Register
    - c) Deposit Permit Register
    - d) Accounts Receivable or Payable Register
    - e) Check or Warrant Register
    - f) General Journal
    - g) Payroll Journal

3. Ledgers
  - a) Expenditure
  - b) Revenue
  - c) Taxes Receivable
  - d) Accounts Payable or Receivable Ledger
  - e) Warrants Payable
  - f) Construction
  - g) Appropriation
  - h) General Ledger
4. Trial Balance
5. Adjusting Entries
6. Statements (Interim or Certified – Individual or All Fund)
  - a) Balance Sheet
  - b) Analysis of Changes in Available Fund Balance
  - c) Cash Receipts
  - d) Expenditures
  - e) Revenues
  - f) Changes in Bonded Indebtedness
  - g) Profit and Loss
  - h) Changes in Fixed Assets
7. Closing Entries
8. Reversing Entries
9. Other
  - a) Schedule of Investments
  - b) Long Term Debt Records
  - c) Inventory Records
  - d) Capital Asset Records
  - e) Lease-Purchase Records
  - f) Depreciation Schedule
  - g) Cost Accounting Records
  - h) Budgets
  - i) Petty Cash Records

B. Retention of Accounting Records.

All Accounting Records should be retained indefinitely in their original form until the governing body gives authorization for destruction.

1. Any accounting record except the Journals and Ledgers which are more than five years old and which were prepared or received in any manner other than pursuant to State Statute may be authorized for destruction, provided that:

- a. There is no continuing need for said record, i.e., long-term transactions, special projects, pending litigations, etc., and;
  - b. There exists in a permanent file, an audit report or reports covering the inclusive period of said record, and that;
  - c. Said audit report or reports were prepared pursuant to procedures outlined in Government Code Section 26909 and other State or Federal audit requirements, and that;
  - d. Said audit(s) contains the expression of an unqualified opinion.
2. Any accounting record created for a specific event or action may be destroyed upon authorization five years from the end of the fiscal period to which it applies.
  3. Any source document detailed in a register, journal, ledger or statement may be authorized for destruction five years from the end of the fiscal period to which it applies.
  4. The following may be destroyed at any time:
    - a. Duplicates (original-subject to aforementioned requirements)
    - b. Rough drafts, notes or working papers (except audit).
    - c. Cards, listings, nonpermanent indices, other papers used for controlling work or transitory files.

C. Retention of Payroll and Personnel Records.

1. All payroll and personnel records should be retained indefinitely. Originals may upon authorization be destroyed after seven years retention, provided said records have been microfilmed and qualify for destruction under Government Code Section 60203 with its various conditions. Payroll and personnel records include the following:
  - a. Accident reports, injury claims and settlements.
  - b. Medical histories
  - c. Injury frequency charts
  - d. Applications, changes and terminations of employees
  - e. Insurance records of employees
  - f. Time sheets
  - g. Job descriptions
  - h. Performance evaluations
  - i. Earning records and summaries
  - j. Retirement records
2. The following associated with personnel records should be retained five years after termination:

- a. Fidelity bonds
- b. Garnishments

D. Retention of Assessing and Tax Collecting Records.

- 1. All assessing records may, upon authorization be destroyed after seven years retention from lien date; however, these records may be destroyed three years after the lien date when said records are microfilmed as provided for in Government Code Section 60203. (Revenue & Taxation Code Section 465)
- 2. Any original unsecured tax roll may upon authorization be destroyed after five years if the delinquent roll or abstract list has been certified as correct and complete by the county auditor or district auditor. (Revenue & Taxation Code Section 2928)
- 3. All tax rolls may upon authorization be destroyed after twelve years retention, if all necessary data needed from the secured delinquencies has been transferred to a delinquency abstract, which should be retained indefinitely. (Revenue & Taxation Code Section 4377)

E. Retention of Records Concerning Long-Term Debt.

- 1. Records of proceedings for the authorization of long-term debt, bonds, warrants, loans, etc., after issuance or execution, may be destroyed if microfilmed as provided for in Government Code Section 60203.
- 2. Terms and conditions of bonds, warrants, and other long-term agreements should be retained until final payment, and thereafter may be destroyed in less than ten years if microfilmed as provided for in Government Code Section 60203.
- 3. Paid bonds, warrant certificates and interest coupons may be destroyed after six months if detailed payment records are kept for ten years.

F. Retention of Minutes.

Minutes of the meetings of the Board of Directors are usually retained indefinitely in their original form. However, they may, upon authorization, be destroyed if said minutes are microfilmed as provided for in Government Code Section 60203.

G. Retention of Construction Records.

Construction records, such as bids, correspondence, change orders, etc., should not be kept in excess of seven years unless they pertain to a project

which includes a guarantee or grant and, in that event, they should be kept for the life of the guarantee or grant plus seven year. As-built plans for any public facility or works should be retained as long as said facility is in existence. Unaccepted bids may be destroyed after two years.

H. Retention of Contracts.

Contracts should be retained for their life plus seven years.

I. Retention of Property Records.

Property records, such as documents of title, should be kept until the property is transferred or otherwise no longer owned by the District.

Sec. ~~3221~~.5 General Provisions

~~3221~~.5.1 Public Records Policy.

Public records of the District shall be open to inspection during regular office hours of the District. "Public Records" are all records of the District except those which are exempted from disclosure by the California Public Records Act (Government Code 6250 et. seq.)

~~3221~~.5.2 Definitions.

A. "Public Records" includes any writing containing information relating to the conduct of the public's business prepared, owned, used or retained by the District regardless of physical medium or characteristics.

B. "Writing" means handwriting, typewriting, printing, Photostatting, photographing, and every other means of recording upon any form of communication or representation, including letters, words, pictures, sounds, or symbols, or a combination thereof and all papers, maps, magnetic or paper tapes, photographic films and prints, magnetic or punched cards, discs, drums, and other documents.

~~3221~~.5.3 Records Exempt from Disclosure.

In accordance with Government Code Section 6254, the following records are exempt from disclosure and shall not be disclosed:

A. Preliminary drafts, notes or interagency or interdistrict memoranda which are not retained by the District in the ordinary course of business, provided that the public interest in withholding such records clearly outweighs the public interest in disclosure.

B. Records pertaining to pending litigation to which the District is a party, or to claims made pursuant to Division 3.6 (commencing with Section 810) of Title 1 of the Government Code, until such litigation or claim has been finally adjudicated or otherwise settled.



C. The District Server backs up all Electronic mail (“E-mail”) daily and retains said e-mail backups for a period of nine (9) days and then it is subject to permanent deletion. This shall include any and all business and personal E-mail that has been saved to any folder or subfolder within any and all user Outlook Profiles on District Mail Servers. It is the responsibility of the user of the District’s E-mail system to print a paper hardcopy, and file appropriately, any e-mails that are considered part of the official record of District business (e.g., contracts or changes, legal correspondence, invoices, etc.). The District shall not be responsible for the retention, backup, or recovery of any personal e-mails.

In the event of litigation to which the District is a party or reasonably anticipates becoming a party, the email users who generate emails relevant to litigation, including, but not limited to, emails, email attachments, Microsoft Word documents, Microsoft Excel spreadsheets, and Power Point presentations, shall print a hard copy of each potentially relevant document to the litigation as it is generated or received (including communications with attorneys or other relevant outside parties that could be protected by applicable privileges) and deliver each hard copy to the Board Secretary for filing in a central litigation file.

D. Personnel, medical or similar files, the disclosure of which would constitute an unwarranted invasion of personal privacy.

E. Geological and geophysical data, plant production data and similar information relating to utility systems development, or market or crop reports, which are obtained in confidence from any person.

F. Test questions, scoring keys, and other examination data used to administer a licensing examination, examination for employment or academic examination.

G. The contents of real estate appraisals, engineering or feasibility estimates and evaluations made for or by the District relative to the acquisition of property, or to prospective public supply and construction contracts, until such time as all the property has been acquired or all of the contract agreements obtained, provided, however, the law of eminent domain shall not be affected by this provision.

H. Information required from any taxpayer in connection with the collection of local taxes, which is received in confidence, and the disclosure of the information to other persons would result in unfair competitive disadvantage to the person supplying such information.

I. Library and museum materials made or acquired and presented solely for reference or exhibition purposes.

J. Records the disclosure of which is exempted or prohibited pursuant to provision of federal or state law, including but not limited to, provisions of the Evidence Code relating to privilege.

3221.5.4                      Government Code 6255.

The District shall withhold from inspection any record that is exempt under the express provisions of the California Public Records Act, including those items set forth above, and may withhold any other record if on the facts of the particular case the public interest served by not making a record public clearly outweighs the public interest served by disclosure of the record.

3221.5.5                      Right of Privacy.

The Board of Directors has determined that the public interest is served by not making public the names, addresses and billing information regarding its customers since the indiscriminate disclosure of such information could constitute an undue invasion of the right of privacy of its customers. Any person seeking such information may file a written appeal with the Secretary of the District. Thereafter, the Board of Directors shall on the facts of the particular case determine whether the public interest served by not making the record public clearly outweighs the public interest served by disclosure of such record. However, nothing herein shall preclude any District employee, including members of the board of directors, access to customer billing information necessary to carry out the regular duties of such employees including the resolution of customer service issues.

3221.5.6                      Procedures for Access to Public Records.

A. Any person desiring to inspect any public record shall identify himself and shall identify the records to be inspected. Exception: Statements of Economic Interest filed pursuant to Government Code Section 81008 (The Political Reform Act of 1974).<sup>1</sup>

B. The Secretary of the District shall determine whether the requested record is subject to inspection. If the Secretary of the District is uncertain whether the record is exempt from disclosure under the California Public Records Act, or whether the facts of the particular case indicate the public interest is served by not making the record public clearly outweighs the public interest served by disclosure of the record, she shall consult with Counsel for the District.

If the Secretary of the District refuses to permit inspection of any record, the person seeking such inspection may appeal the decision of the Secretary of the District to the Board of Directors. Such appeal shall be in writing and shall be filed with the Secretary of the District not later than 10 working days after the refusal of the Secretary of the District to permit inspection.

---

1            Government Code Section 81008 states, “no conditions whatsoever shall be imposed upon persons desiring to inspect or reproduce reports and statements filed under this title, not shall any information or identification be required from such persons”.

C. The Board of Directors shall consider and rule upon the appeal within 30 days after the filing thereof, and shall thereupon notify the applicant in writing of its decision. If the applicant has filed a written appeal with the Board, the applicant shall be notified of the time and place of the meeting of the Board to consider the matter, and the applicant may appear in person before the Board when the matter is heard. If the Board fails to give written notice of its decision within 30 days of the filing of the appeal, the appeal shall be deemed denied.

D. Inspection of public records shall be made only in the District office, and no document shall be removed there from. A representative of the District may be present during the inspection of any records.

E. The District will make every effort to cooperate with the person seeking to inspect documents; however, if the request is to inspect a substantial quantity of documents or documents not readily available, the District shall have a reasonable period of time to collect such records and may require the inspection of such records to take place at a future date.

F. Any person may obtain a copy of any identifiable public record. Upon request, an exact copy shall be provided unless impracticable to do so. Computer data shall be provided in a form determined by the District.

G. A request for a copy of an identifiable written public record, or information produced there from or a certified copy of such record shall be accompanied by payment of a fee in the amount of \$0.25 for the first page and \$0.10 for each page thereafter. In some cases, it may be necessary to send a document or document(s) to a printer or commercial copying service; and in such cases, the person requesting copies shall pay the total direct cost. Blueprint reproduction shall be \$5.00 per print, plus staff time in excess of one-half hour. A request for a copy of a tape recording of a meeting of the Board of Directors of the District shall be accompanied by payment of a fee of \$10.00.

H. This public records policy of the District shall at all times be subject to the California Public Records Act, that it may be amended from time to time, and if there is any conflict between that act and this policy, the act shall prevail.

3221.5.7 Records Retention and Destruction Policy.

All records identified in the records retention schedules attached hereto shall be retained in original form in the District offices for the number of years indicated in the column designated, "Responsible Department".

Upon transfer to archives, any identical copies or duplicates shall be destroyed and the original shall be stored for the number of years indicated in the column designated, "open/active".

The column designated as “closed” indicates the disposition of a record after reaching its retention period.

The column designated as “disposal” indicates how the record is to be disposed of, whether it be archived, tossed, or shredded.

The column designated as “notes” shall designate specific information relating to a particular document and how it is to be retained or destroyed. It may also contain miscellaneous notes pertinent to the specific document.

No record shall be destroyed without the written authorization from the department manager and the general manager. If the department manager and/or the general manager have determined that the record has continuing value due to litigation or any other reason, it shall be retained either in original form or by microfilming or imaging.

Sec. ~~3221~~.6 California Public Records Act.

The California Public Records Act is made a part of Article ~~3221~~ and incorporated as Exhibit “A” attached.

Sec. ~~3221~~.7 Records Retention Schedule.

The District’s Records Retention Schedule is made a part of Article ~~3221~~ and incorporated as Exhibit “B” attached.

<sup>1</sup> The following requirements apply to microfilming:

- (1) The item must be photographed; microphotographed; reproduced by electronically recorded video images on magnetic surfaces; recorded on optical disk; reproduced on film or any other medium which does not permit additions, deletions or changes to the original document in compliance with the minimum standards and/or guidelines as recommended by the American National standards Institute or the Association for Information and Image Management for recording of permanent records or nonpermanent records, whichever applies; and
- (2) The original must be accurately reproduced in all details; and
- (3) The reproductions must be stored in conveniently accessible files, and provision must be made for preserving, examining and using the files.

<p>ARTICLE <del>32</del> <u>(Renumbered as Article 21 by Resolution 5006)</u></p> <p>New policy added 2/28/05</p> <p>Sec. 32.5.3(C) – Rev. 10/06</p> <p>Records Retention Schedule (Email) – Rev. 10/06</p> <p>Exhibit B – Rev. 2/10</p> <p>Exhibit A – Rev. 12/10</p> <p>Exhibit B – Rev. 8/11</p>
---

**Article 3322. Social Media Policy and Procedure**

Sec. 3322.1 General Purpose.

This Social Media Policy ("Policy") establishes guidelines for the establishment and use by the Fallbrook Public Utility District ("District") of social media sites as a means of conveying information to members of the public. The intended purpose of District social media sites is to disseminate information from the District about the District's mission, meetings, activities, and current issues to members of the public. The District has an overriding interest and expectation in protecting the integrity of the information posted on its social media sites and the content that is attributed to the District and its officials.

Sec. 3322.2 Definitions.

The following words and phrases whenever used in these Policies and Procedures shall have the meaning defined in this section:

Sec. 3322.2.1 "Social media sites" means content created by individuals, using accessible, expandable, and upgradable publishing technologies, through and on the internet. Examples of social media include, but are not limited to, Facebook, Twitter, Instagram, Blogs, RSS, YouTube, and LinkedIn.

Sec. 3322.2.2 "District social media sites" means social media sites which the District establishes and maintains, and over which it has control over all postings, except for advertisements or hyperlinks by the social media site's owners, vendors, or partners. District social media sites shall supplement, and not replace, the District's required notices and standard methods of communication.

Sec. 3322.2.3 "Posts" or "postings" means information, articles, pictures, videos or any other form of communication posted on a District social media site.

Sec. 3322.3 General Policy.

Sec. 3322.3.1 The District's official website at www.fpud.com (or any domain owned by the District) will remain the District's primary means of internet communication.

Sec. 3322.3.2 The establishment of District social media sites is subject to approval by the General Manager or his/her designee. Upon approval, District social media sites shall bear the name and/or official logo of the District.

Sec. 3322.3.3 Content on District social media sites is subject to oversight by the General Manager's Department.

Sec. 3322.3.4 District social media sites shall clearly state that such sites are

maintained by the District and that the sites comply with the District's Social Media Policy.

Sec. 3322.3.5 District social media sites shall link back to the District's official website for forms, documents, online services, and other information necessary to conduct business with the District whenever possible.

Sec. 3322.3.6 The District's Public Affairs Specialist shall monitor content on District social media sites to ensure adherence to both the District's Social Media Policy and the interest and goals of the District.

Sec. 3322.3.7 District social media sites shall be managed consistent with the Brown Act. Members of the District's Board of Directors shall not respond to, "like", "share", retweet, or otherwise participate in any published postings, or use the site or any form of electronic communication to respond to, blog, or engage in serial meetings, or otherwise discuss, deliberate, or express opinions on any issue within the subject matter jurisdiction of the body.

Sec. 3322.3.8 The District reserves the right to terminate any District social media site at any time without notice.

Sec. 3322.3.9 District social media sites shall comply with usage rules and regulations required by the site provider, including privacy policies.

Sec. 3322.3.10 The District's Social Media Policy shall be displayed to users or made available by hyperlink.

Sec. 3322.3.11 All District social media sites shall adhere to applicable federal, state, and local laws, regulations, and policies.

Sec. 3322.3.12 District social media sites are subject to the California Public Records Act. Any content maintained on a District social media site that is related to District business, including a list of subscribers, posted communication, and communication submitted for posting, may be considered a public record and subject to public disclosure.

Sec. 3322.3.13 Employees representing the District on District social media sites shall conduct themselves at all times as a professional representative of the District and in accordance with all District policies.

Sec. 3322.3.14 All District social media sites shall utilize authorized District contact information for account set-up, monitoring, and access. The use of personal email accounts or phone numbers by any District employee is not allowed for the purpose of setting-up, monitoring, or accessing a District social media site.

Sec. 3322.3.15 District social media sites may contain content, including but not

limited to, advertisements or hyperlinks over which the District has no control. The District does not endorse any hyperlink or advertisement placed on District social media sites by the social media site's owners, vendors, or partners.

Sec. 3322.3.16 The District reserves the right to change, modify, or amend all or part of this policy at any time.

Sec. 3322.4 Content Guidelines.

Sec. 3322.4.1 The content of District social media sites should only pertain to District-sponsored or District-endorsed programs, services, and events. Content includes, but is not limited to, information, photographs, videos, and hyperlinks.

Sec. 3322.4.2 Content posted to the District's social media sites must contain hyperlinks directing users back to the District's official website for in-depth information, forms, documents, or online services necessary to conduct business with the Fallbrook Public Utility District, whenever possible.

Sec. 3322.4.3 The District shall have full permission or rights to any content posted, including photographs and videos.

Sec. 3322.4.4 Any employee authorized to post items on any of the District's social media sites shall review, be familiar with, and comply with the social media site's use policies and terms and conditions.

Sec. 3322.4.5 Any employee authorized to post items on any of the District's social media sites shall not express his or her own personal views or concerns through such postings. Instead, postings on any of the District's social media sites by an authorized District employee shall only reflect the views of the District.

Sec. 3322.4.6 Postings must contain information that is freely available to the public and not be confidential as defined by any District policy or state or federal law.

Sec. 3322.4.7 Postings may NOT contain any personal information, except for the names of employees whose job duties include being available for contact by the public.

Sec. 3322.4.8 Postings to District social media sites shall NOT contain any of the following:

Sec. 3322.4.8.1 Comments that are not topically related to the particular posting being commented upon;

Sec. 3322.4.8.2 Comments in support of, or opposition to, political campaigns, candidates or ballot measures;

Sec. ~~3322~~.4.8.3 Profane language or content;

Sec. ~~3322~~.4.8.4 Content that promotes, fosters, or perpetuates discrimination on the basis of race, creed, color, age, religion, gender, marital status, or status with regard to public assistance, national origin, physical or mental disability or sexual orientation, as well as any other category protected by federal, state, or local laws;

Sec. ~~3322~~.4.8.5 Sexual content or links to sexual content;

Sec. ~~3322~~.4.8.6 Solicitations of commerce;

Sec. ~~3322~~.4.8.7 Conduct or encouragement of illegal activity;

Sec. ~~3322~~.4.8.8 Information that may tend to compromise the safety or security of the public or public systems; or

Sec. ~~3322~~.4.8.9 Content that violates a legal ownership interest of any other party.

Sec. ~~3322~~.4.9 These guidelines shall be displayed to users or made available by hyperlink on all District social media sites. Any content removed based on these guidelines must be retained, including the time, date, and identity of the poster, when available.

Sec. ~~3322~~.4.10 The District reserves the right to implement or remove any functionality of its social media sites, when deemed appropriate by the General Manager or his/her designee. This includes, but is not limited to, information, articles, pictures, videos, or any other form of communication that is posted on a District social media site.

Sec. ~~3322~~.4.11 Except as expressly provided in this Policy, accessing any social media site shall comply with all applicable District policies pertaining to communications and the use of the internet by employees, including email content.

Sec. ~~3322~~.4.12 All of the content on District social media sites is subject to oversight by the General Manager's Office. The District reserves the right to change, modify, or amend all or part of this policy at any time.

ARTICLE 33 ( <a href="#">Renumbered as Article 22 by Resolution 5006</a> )
Adopted in its Entirety – 9/18



**Attachment C**  
**Resolution 5006**

**RESOLUTION NO. 5006**

**A RESOLUTION OF THE BOARD OF DIRECTORS OF THE  
FALLBROOK PUBLIC UTILITY DISTRICT UPDATING  
ADMINISTRATIVE CODE TABLE OF CONTENTS, RENUMBERING OF  
EXISTING ARTICLES TO CREATE A SEQUENTIAL ORDER, AND  
UPDATING INTERNAL SECTION CROSS-REFERENCES AS  
NECESSARY**

\* \* \* \* \*

**WHEREAS**, the District Administrative Code is the overarching governing document for the administration of the District; and

**WHEREAS**, some Articles have recently been repealed, leaving unused Article numbers; and

**WHEREAS**, the Administrative Code Table of Contents requires updates to renumber Articles in a sequential order; and

**WHEREAS**, corresponding re-renumbering of existing Articles and updates of internal section cross-references, is also required.

**NOW, THEREFORE, BE IT RESOLVED THAT:**

1. Administrative Code Table of Contents shall be amended with the the proposed revisions as shown in Attachment "A" and are incorporated herein.
2. Administrative Code Articles 14 through 29, 32, and 33 shall be renumbered, and internal section corss-references shall be updated as necessary, as shown in Attachment "B" and are incorporated herein.
3. All other provisions of the Administrative Code shall remain unchanged and in full force and effect.

**PASSED AND ADOPTED** by the Board of Directors of the Fallbrook Public Utility District at a regular meeting of the Board held on the 22<sup>nd</sup> day of February, 2021, by the following vote:

AYES:  
NOES:  
ABSTAIN:  
ABSENT:

\_\_\_\_\_  
President, Board of Directors

ATTEST:

\_\_\_\_\_  
Secretary, Board of Directors

## **Attachment A**

# FALLBROOK PUBLIC UTILITY DISTRICT

## ADMINISTRATIVE CODE INDEX

### ARTICLE 1           GENERAL PROVISION

- Sec. 1.1           Purpose
- Sec. 1.2           Adoption
- Sec. 1.3           Changes

### ARTICLE 2           BOARD OF DIRECTORS, GUIDELINES FOR

- Sec. 2.1           Powers - Delegation
- Sec. 2.2           Officers of Board of Directors
  - 2.2.1           Election of Officers
  - 2.2.2           Duties of President
  - 2.2.3           Duties of Vice President
- Sec. 2.3           Other Officers of the District
- Sec. 2.4           Employment of Professionals
  - 2.4.1           General Counsel
  - 2.4.2           Auditor
- Sec. 2.5           Time and Place of Board Meetings
- Sec. 2.6           Special Meetings
- Sec. 2.7           Quorum
- Sec. 2.8           Actions
- Sec. 2.9           Order of Procedure of Meetings
  - 2.9.1           Guidelines for Conduct of Board Meetings
- Sec. 2.10          Consent Calendar
- Sec. 2.11          Minutes
- Sec. 2.12          Directors' Compensation
- Sec. 2.13          Board Packets
- Sec. 2.14          Board Committees
- Sec. 2.15          Ethics Policy
- Sec. 2.16          Comprehensive Code of Conduct
  - 2.16.1          Purposes and Goals of Code of Conduct
  - 2.16.2          Minimum Expectations for Conduct of Board Meetings
  - 2.16.3          Breaches of Order at Meetings; Sanctions
  - 2.16.4          Violations of Board Policies or Law Outside of Board Meetings
  - 2.16.5          Sanctions
  - 2.16.6          Authority of Administration to Provide for Security
  - 2.16.7          Board Orientation and Training
- Sec. 2.17          Directors Expenses Incurred on District Business
  - 2.17.1          Directors and Meetings
  - 2.17.2          Prepayment of Otherwise Reimbursable Expenses
  - 2.17.3          Reimbursement of Expenses
  - 2.17.4          Meals and Lodging
  - 2.17.5          Entertainment
  - 2.17.6          Incidental Expenses
  - 2.17.7          Director's Responsibility
  - 2.17.8          Reports
  - 2.17.9          Penalties

\* As of February 2021, the Board of Directors adopted Resolution 5006, and the Table of Contents was renumbered to remove unused articles and make existing articles sequential.

- 2.17.10 Ethics Training
- Sec. 2.18 Gifts and Disclosure
  - 2.18.1 Annual Disclosure of Reimbursements
  - 2.18.2 Prohibition against Acceptance of Honorarium
  - 2.18.3 Permissible Gifts May Not Exceed \$500.00
  - 2.18.4 Penalties for Violations
    - Cal Pen Code 403 (Appendix A)
    - Cal Gov Code 3060 (Appendix B)

**ARTICLE 3 CONFLICT OF INTEREST CODE**  
~~Designated Users (Appendix A)~~ **(Repealed Feb. 27, 2017)**

**ARTICLE 4 PERSONNEL**

- Sec. 4.1 General Manager
- Sec. 4.2 Memoranda of Understanding
- Sec. 4.3 Personnel Regulations
- Sec. 4.4 Expense Reimbursement and Code of Conduct
  - 4.4.1 Expenses Incurred on District Business
- Sec. 4.5 Code of Conduct
  - 4.5.1 General Rule with Respect to Conflicts of Interest
  - 4.5.2 Acceptance of Gifts, Gratuities or Benefits
  - 4.5.3 Actions and Conduct Designed to Build Public Confidence
  - 4.5.4 Use of Confidential Information
  - 4.5.5 Use of District Employment and Facilities for Private Gain
  - 4.5.6 Contracts with the District
  - 4.5.7 Personal Investments
  - 4.5.8 Behavior in the Workplace
  - 4.5.9 Ethics and Sexual Harassment Avoidance Training
- Sec. 4.6 Memberships in Professional Organizations

**ARTICLE 5 DISTRICT PROCUREMENT PROCEDURES (Renumbered from previous Article 14)**

- Sec. 5.1 Authority
  - Sec. 5.2 General
- Sec. 5.3 Procurement Philosophy
- Sec. 5.4 Definitions
- Sec. 5.5 Procedures for the Purchase of Public Projects, Maintenance, and Articles
  - Sec. 5.6 Procedures for Procurement of Professional Services
  - Sec. 5.7 Prequalification
  - Sec. 5.8 Emergencies
  - Sec. 5.9 Exceptions to Procurement Requirements
  - Sec. 5.10 Local Procurements
  - Sec. 5.11 Sale of Surplus Property/Equipment and Scrap Metal
  - Sec. 5.12 Use of District Credit Card
  - Sec. 5.13 Contract Amendment Procedures

**ARTICLE 6 BUDGET AND FUND MANAGEMENT (Renumbered from previous Article 15)**

\* As of February 2021, the Board of Directors adopted Resolution 5006, and the Table of Contents was renumbered to remove unused articles and make existing articles sequential.

Sec. 6.1	District's Annual Budget
6.1.1	Annual Budget Resolution
Sec. 6.2	Treasurer's Fund
Sec. 6.3	General Fund
Sec. 6.4	Utility Funds
Sec. 6.5	Capital Funds
Sec. 6.6	Equipment Fund
Sec. 6.7	Debt Service Funds
Sec. 6.8	Appropriated Fund Balances
6.8.1	Utility Funds Appropriated Fund Balances
6.8.2	Utility Capital Funds Appropriated Fund Balances
6.8.3	Debt Service Funds
Sec. 6.9	Petty Cash

**ARTICLE 7A INSURANCE CLAIMS HANDLING PROCEDURES (JPIA)  
(Renumbered from previous Article 16A)**

Sec. 7A.1	General
Sec. 7A.2	General Handling Procedures
7A.2.1	Rejection of Sufficient and Timely Claims
7A.2.2	Rejection of Insufficient and Late Claims
7A.2.3	Late Claims
Sec. 7A.3	Small Claims Settlement Option

**ARTICLE 7B INSURANCE CLAIMS HANDLING PROCEDURES (DISTRICT-  
GOVERNMENT CODE 905) (Renumbered from previous Article  
16B)**

Sec. 7B.1	General
Sec. 7B.2	Claims Time Limitations
Sec. 7B.3	Claims Required
Sec. 7B.4	Form of Claim
Sec. 7B.5	Claim Prerequisite to Suit
Sec. 7B.6	Suit
Sec. 7B.7	Severability

**ARTICLE 8 DISTRICT INSPECTIONS BY A REGULATORY AGENCY  
(Renumbered from previous Article 17)**

Sec. 8.1	General
Sec. 8.2	Purpose
Sec. 8.3	Scope
Sec. 8.4	Responsibilities
Sec. 8.5	Procedures

**ARTICLE 9 ANNEXATIONS (Renumbered from previous Article 18)**

Sec. 9.1	Incorporation by Reference
Sec. 9.2	General
Sec. 9.3	Annexation Payments
Sec. 9.4	Conditions for Annexation
Sec. 9.5	1950 Annexation

\* As of February 2021, the Board of Directors adopted Resolution 5006, and the Table of Contents was renumbered to remove unused articles and make existing articles sequential.

Sec. 9.6	1958 Annexation
Sec. 9.7	Airpark Annexation
Sec. 9.8	Red Mountain Ranch Annexation
Sec. 9.9	DeLuz Annexation
Sec. 9.10	Annexation/Detachments between Adjacent Districts
Sec. 9.11	Partial Annexations
Sec. 9.12	DeLuz Service Area Annexations
9.12.1	Additional Costs
Sec. 9.13	Improvement District "S"
9.13.1	Annexation Fees and Costs
9.13.2	Adjustment Review

**ARTICLE 10                    WATER SERVICE CONNECTIONS AND RULES FOR DELIVERY OF WATER (Renumbered from previous Article 19)**

Sec. 10.1	Definitions
Sec. 10.2	Remote Meter Agreements
Sec. 10.3	Temporary Service Agreements
Sec. 10.4	Engineering Fees
10.4.1	Plan Check Fees
10.4.2	Fees for District to Inspect Contractor Installed Facilities
Sec. 10.5	Rules for Service of Water
Sec. 10.6	Meter and Service Line Installations
Sec. 10.7	Meter Relocation Fees
Sec. 10.8	Connection/Capacity Fees
10.8.1	Replacement of Removed Meters
10.8.2	Meter Testing Costs
10.8.3	Adjustment to Fees for Meters and Connections
Sec. 10.9	Credit for Connection Fees and Fees for Increased Meter Size
Sec. 10.10	San Diego County Water Authority Connection Fees
Sec. 10.11	San Diego County Water Authority Permanent Special Agricultural Water Program Administration
10.11.1	Purpose
10.11.2	Qualification
10.11.3	Certification and Recertification
10.11.4	Acknowledgement
10.11.5	Exit and Re-entry into the PSAWR
10.11.6	Implementation of Mandatory PSAWR Supply Reductions
Sec. 10.12	Installation or Extension Line Costs
Sec. 10.13	Customer Valve
Sec. 10.14	Water Must Pass Through Meter
Sec. 10.15	Mains, Service Pipes, Equipment Belonging to District
Sec. 10.16	Meter Area Clean and Consumer Line Free from Leaks
Sec. 10.17	Fires
Sec. 10.18	Access to Meters
Sec. 10.19	Temporary Discontinuance of Service for Repairs, etc.
Sec. 10.20	Allowances or Rebates
Sec. 10.21	Water Served to Others
Sec. 10.22	Backflow Prevention Devices
10.22.1	Type of Backflow Protection Required
10.22.2	Backflow Device Installation on New Services

\* As of February 2021, the Board of Directors adopted Resolution 5006, and the Table of Contents was renumbered to remove unused articles and make existing articles sequential.

	10.22.3	Reduced Pressure Backflow Preventer Retrofits
	10.22.4	Reduced Pressure Backflow Preventer Device Retrofit – Installed by Property Owner
	10.22.5	Well Destruction and Alteration
Sec.	10.23	Booster Pumps
	10.23.1	Fallbrook Service Area Pressure Zones
	10.23.2	DeLuz Heights Service Area Pressure Zones
Sec.	10.24	Fire Hydrants
Sec.	10.25	Automatic Sprinkler and Fire Protection Systems
Sec.	10.26	Construction Meters
Sec.	10.27	Water Used for Annual Crops
Sec.	10.28	Illegal Use of Water
Sec.	10.29	Water Service Outside District
Sec.	10.30	Application of Water Service to Affordable Housing
	10.30.1	Review of Service Policies
Sec.	10.31	Administrative Fees

**ARTICLE 11 SEWER SERVICE REQUIREMENTS AND FEES (Renumbered from previous Article 20)**

Sec.	11.1	Definitions
Sec.	11.2	Prohibited Connections
Sec.	11.3	Prohibited Uses and Prohibited Discharges
Sec.	11.4	Permit Required
Sec.	11.5	Sewer Permit Application Process
	11.5.1	Submission of Application
	11.5.2	Determination of Equivalent Dwelling Unit and Strength
	11.5.3	Payment of Fees
Sec.	11.6	Sewer Availability Forms and Letters
Sec.	11.7	Equivalent Dwelling Unit Schedules
Sec.	11.8	Determination and Classification of Strength (BOD and SS)
Sec.	11.9	Sewer Use Permits
Sec.	11.10	Temporary Sewer Service Agreement
Sec.	11.11	Permit Modifications
Sec.	11.12	Permits Non-Transferable
Sec.	11.13	Application of Sewer Service to Affordable Housing
Sec.	11.14	Sewer Use Requirements
	11.14.1	General Conditions for Sewage Disposal
	11.14.2	Discharge Prohibition
	11.14.3	FOG Compliance Program
Sec.	11.15	Miscellaneous Provisions
	11.15.1	Provide Information
	11.15.2	Users Outside the District
	11.15.3	Agreements
Sec.	11.16	Fees and Charges
	11.16.1	Sewer Service Charges
	11.16.2	Capacity Fees
	11.16.3	Plan Check Fees
	11.16.4	Lateral Fees
	11.16.5	Fees for District to inspect Contractor-Installed Facilities
	11.16.6	Annexation Fees
	11.16.7	Fees and Charges May Be Collection with Taxes
Sec.	11.17	Right of Entry and Inspection

\* As of February 2021, the Board of Directors adopted Resolution 5006, and the Table of Contents was renumbered to remove unused articles and make existing articles sequential.



Sec. 11.18	Enforcement – Generally
Sec. 11.19	Administrative Enforcement
11.19.1	Monitoring
11.19.2	Citations
11.19.3	Termination of Service and Revocation of Permit
11.19.4	Permit Amendment
11.19.5	Cost Recovery
11.19.6	Administrative Compliant – Pretreatment Violations
Sec. 11.20	Public Nuisance
Sec. 11.21	Civil Enforcement
11.21.1	Injunction
11.21.2	Other Actions
11.21.3	Criminal Enforcement
Sec. 11.22	Appeal Process
11.22.1	Appeals of Determinations and Redeterminations of EDUs
11.22.2	Appeals of Special Use Permit Requirements
11.22.3	Appeals of Administrative Enforcement Actions
11.22.4	Hearing on Appeal
11.22.5	Appeal to Board
11.22.6	Judicial Review
Sec. 11.23	Delivery of Notice

**ARTICLE 12 WATER AND SEWER RATES AND SERVICE CHARGES  
(Renumbered from previous Article 21)**

Sec. 12.1	Volumetric Water, Recycled Water, and Pumping Rates
Sec. 12.2	Monthly Fixed Charges
Sec. 12.3	MWD Readiness-to-Serve Charge (RTS) and San Diego County Water Authority Infrastructure Access Charge (IAC)
Sec. 12.4	Water Capital Improvement Charge
Sec. 12.5	Billing Periods
12.5.1	Unclaimed Funds
Sec. 12.6	Meter Locks and Restrictors
Sec. 12.7	Meter Not Registering
Sec. 12.8	Water Rates or Service Charges Lien on Property
12.8.1	Theft of Water
Sec. 12.9	Volumetric Wastewater Charges
Sec. 12.10	Monthly Fixed Wastewater Charge
12.10.1	Wastewater Capital Improvement Charge Customer Classes (Appendix A)

**ARTICLE 13 EASEMENTS (Renumbered from previous Article 22)**

Sec. 13.1	Requirement for Easements
Sec. 13.2	Acceptance of Easements
Sec. 13.3	Granting of Easements

**ARTICLE 14 CONSTRUCTION, REGULATIONS GOVERNING (Renumbered  
from previous Article 23)**

Sec. 14.1	Water Line Extensions and Replacements, by the District
Sec. 14.2	Water Line Extensions, Privately Financed

\* As of February 2021, the Board of Directors adopted Resolution 5006, and the Table of Contents was renumbered to remove unused articles and make existing articles sequential.

Sec. 14.3	Water & Sewer Line Extensions, Repayment Agreements
14.3.1	Administrative Costs
Sec. 14.4	Pipeline Extensions, Sewer
14.4.1	Process
14.4.2	Agreement
14.4.3	Fees
Sec. 14.5	Construction Ownership and Maintenance of Sewer Lateral Pipelines
Sec. 14.6	Temporary Sewer Service Connections

**ARTICLE 15                   STANDBY OR AVAILABILITY CHARGES (Renumbered from previous Article 24)**

Sec. 15.1	Definition
Sec. 15.2	Water Availability Charges
15.2.1	Fallbrook Service Area
15.2.2	DeLuz Improvement District
Sec. 15.3	Exemptions
Sec. 15.4	Collection of Standby/Availability Charges
Sec. 15.5	Deferral of Charge
15.5.1	Application
15.5.2	Appeal to Board of Directors
15.5.3	Deferred Charges on Restricted Parcels
15.5.4	Deferred Charges on Partial Parcels
15.5.5	Surcharge
15.5.6	Refunds
15.5.7	Enforcement Procedures
Sec. 15.6	Certified Copies
Sec. 15.7	Correction of Errors

**ARTICLE 16                   TAX LEVY (Renumbered from previous Article 25)**

Sec. 16.1	Definitions
Sec. 16.2	General Bonded Indebtedness
Sec. 16.3	Money to be Raised by Taxation
Sec. 16.4	Full Valuation of Taxable Property
Sec. 16.5	Certified Copies

**ARTICLE 17                   WATER SHORTAGE RESPONSE PLAN (Renumbered from previous Article 26)**

Sec. 17.1	Declaration of Policy
17.1.1	PSAWR Reduction Program
17.1.2	PSAWR Reduction Compliance
Sec. 17.2	Findings
Sec. 17.3	Application
Sec. 17.4	Determination and Declaration by General Manager of Water Supply Conditions
Sec. 17.5	Implementation of Emergency Water Management Program
Sec. 17.6	Duration of Declaration
Sec. 17.7	Mandatory and Discretionary Use of Recycled Water
Sec. 17.8	Water Conservation Stages

\* As of February 2021, the Board of Directors adopted Resolution 5006, and the Table of Contents was renumbered to remove unused articles and make existing articles sequential.

	17.8.1	Normal Conditions
	17.8.2	Water Shortage Response Level 1 – Water Shortage Watch Condition
	17.8.3	Water Shortage Response Level 2 – Water Shortage Alert Condition
	17.8.4	Water Shortage Response Level 3 – Water Shortage Critical Condition
	17.8.5	Water Shortage Response Level 4 – Water Shortage Emergency Condition
	17.8.6	Drought Rates
Sec.	17.9	Implementation of Conservation Levels
Sec.	17.10	Variances
	17.10.1	Application
	17.10.2	Supporting Documentation
	17.10.3	Required Findings for Variance
	17.10.4	Approval Authority
	17.10.5	Appeals to FPUD Board of Directors

**ARTICLE 18            INVESTMENT POLICY (Renumbered from previous Article 27)**

Sec.	18.1	General
	18.1.1	Delegation of Authority
	18.1.2	Investment Objectives
	18.1.3	Prudent Investor Standard
Sec.	18.2	Treasurer’s Annual Statement of Investment Policy
	18.2.1	Security of Principal Policy
	18.2.2	Liquidity Policy
	18.2.3	Return Policy
	18.2.4	Maturity Policy
	18.2.5	Prohibited Securities
Sec.	18.3	Internal Controls
Sec.	18.4	Permissible Investments
	18.4.1	Government Obligations
	18.4.2	Banker’s Acceptance
	18.4.3	Commercial Paper
	18.4.4	Medium-Term Notes
	18.4.5	Repurchase Agreements
	18.4.6	Negotiable Certificates of Deposit
	18.4.7	State Local Agency Investment Fund (LAIF)
	18.4.8	San Diego County Treasurer’s Fund
	18.4.9	Passbook and Money Market Savings Accounts
	18.4.10	State Obligations/State of California and Other States
	18.4.11	California Local Agency Obligations
	18.4.12	Joint Powers Authority Pool
	18.4.13	Money Market Mutual Funds
	18.4.14	Mortgage Pass-Through Securities and Asset-Backed Securities
	18.4.15	Supranationals
Sec.	18.5	Maturity/Limit of Investments
Sec.	18.6	Reporting Requirements
		State and Federal Credit Union Deposit Restrictions
		Acknowledgement (Attachment A)

\* As of February 2021, the Board of Directors adopted Resolution 5006, and the Table of Contents was renumbered to remove unused articles and make existing articles sequential.

**ARTICLE 19            RECYCLED WATER PROGRAM (Renumbered from previous Article 28)**

- Sec. 19.1            Declaration of Policy
- Sec. 19.2            Statutory Requirements
- Sec. 19.3            Approved Use
- Sec. 19.4            Definitions
- Sec. 19.5            Administration
- Sec. 19.6            Suspension or Termination of User Service
  - 19.6.1            Reasons
  - 19.6.2            Procedure
  - 19.6.3            Appeals of the Suspension or Termination Notice
  - 19.6.4            Prohibited Connections
- Sec. 19.7            Implementation
  - 19.7.1            Designation of Users
  - 19.7.2            Appeal
  - 19.7.3            Design and Construction of On-Site Facilities
  - 19.7.4            Recycled Water Supervisor
  - 19.7.5            Conversion of Existing Facilities
  - 19.7.6            User Agreement Form
- Sec. 19.8            Water Meter Requirement
- Sec. 19.9            Public Safety Requirements
  - 19.9.1            General Requirements
  - 19.9.2            Backflow Protection at the Service Meter
- Sec. 19.10           Truck Load Delivery of Recycled Water
- Sec. 19.11           Miscellaneous
- Sec. 19.12           Non-Liability

**ARTICLE 20            EMERGENCY ACTION PLAN (EAP) (Renumbered from previous Article 29)**

**ARTICLE 21            RECORDS RETENTION AND DESTRUCTION POLICY (Renumbered from previous Article 32)**

- Sec. 21.1            Purpose
- Sec. 21.2            Authorization to Implement Policy
- Sec. 21.3            Government Code (Chapter 7) Sections Providing for the Destruction of Records of Special Districts
- Sec. 21.4            State Controller’s Guidelines
- Sec. 21.5            General Provisions
  - 21.5.1            Public Records Policy
  - 21.5.2            Definitions
  - 21.5.3            Records Exempt from Disclosure
  - 21.5.4            Government Code 6255
  - 21.5.5            Right of Privacy
  - 21.5.6            Procedures for Access to Public Records
  - 21.5.7            Records Retention and Destruction Policy
- Sec. 21.6            California Public Records Act (Exhibit A)
- Sec. 21.7            Records Retention Schedule (Exhibit B)

\* As of February 2021, the Board of Directors adopted Resolution 5006, and the Table of Contents was renumbered to remove unused articles and make existing articles sequential.

**ARTICLE 22                    SOCIAL MEDIA POLICY AND PROCEDURE (Renumbered from  
previous Article 33)**

- Sec. 22.1                    General Purpose
- Sec. 22.2                    Definitions (Secs. 33.2.1—33.2.3)
- Sec. 22.3                    General Policy (Secs. 33.3.1—33.3.16)
- Sec. 22.4                    Content Guidelines (Secs. 33.4.1—33.4.12)

\* As of February 2021, the Board of Directors adopted Resolution 5006, and the Table of Contents was renumbered to remove unused articles and make existing articles sequential.

## **Attachment B**

**Article 5. District Procurement Procedures.**

Sec. 5.1 Authority.

California Public Contract Code Sections 20200-20207.7, as well as other provisions in the California Public Contract Code, certain miscellaneous statutes found in the Public Utility District Act (Public Utilities Code Section 15501 et seq.), and the California Government Code, govern procurement (purchasing and contracting) by the District of the following:

- Articles such as goods, materials, supplies, equipment, capital assets, and advertising
- Works of construction, alteration, and non-professional services (including repair and maintenance)
- Professional services

The District has elected to become subject to the provisions of the Uniform Public Construction Cost Accounting Act (the "Act"), Public Contract Code Section 22000 et seq., which provides alternative procedures for the bidding and awarding of public contracts. As provided in Public Contract Code Section 22003, these procedures may also be utilized for maintenance work and other work that does not fall within the definition of "public project." Accordingly, it is the District's intent to utilize these procedures for "public projects" and all other purchases otherwise subject to Public Contract Code Sections 20200-20207.7.

The provisions of this Article 5 shall not apply to the acquisition of land by the District.

Sec. 5.2 General.

The ongoing operation of the District requires the procurement of various items, construction and services. Since it is necessary to procure these items, construction and services on a regular basis to carry on the day-to-day operations of the District, and since the Board of Directors reviews and approves all procurements through the budgeting process, or otherwise approves procurements by separate action from time to time, the following formal procurement policies and procedures are provided for implementation by District staff. These formal procedures are intended to implement the above-listed requirements of the California Public Contract Code, California Government Code, and California Public Utilities Code, which are mandatory for Public Utility Districts located within the State of California. State law forbids any director or other officer of the District from being interested, directly or indirectly, in any contract awarded or to be awarded by the Board, or in the profits to be derived from it.

Sec. 5.3      Procurement Philosophy.

Purchases of goods, materials, supplies, equipment, and capital assets shall be made from time to time, in the most economical quantity, in order to provide the District with maximum benefit for minimum expenditures. Quality and reliability of products are also important factors which may, on a case-by-case basis, cause rejection of an inferior product that does not meet specified requirements. It is also essential that purchases of all goods, materials, supplies, equipment, and capital assets be done by the District in a fair and open manner that promotes public confidence in the District and reinforces the public perception of fairness and equal opportunity for all competing vendors offering their products or services to the District. Contracts for works of construction and all services shall be made from time to time, after complying with applicable legal requirements and these procurement policies and procedures. To the extent permitted by law, and subject to the limitations established in Section 5.10, purchases should be made from vendors located within the boundaries of the District.

Sec. 5.4      Definitions.

- a.      Articles. Goods, materials, supplies, equipment, capital assets, and advertising required to carry on the day-to-day operations of the District, including without limitation, office supplies, computer hardware and software, communications equipment, equipment, materials and supplies for distribution and treatment, including meters, meter parts, and pipeline materials.
- b.      Commission. The California Uniform Construction Cost Accounting Commission.
- c.      Designee. The General Manager may authorize the following persons as his designee in those areas in which they exercise budgeting control:
  - (1)      Assistant General Manager/Chief Financial Officer – (Articles related to office equipment and supplies, all computer hardware and software, communication equipment, and contract services).
  - (2)      Operations Manager – (Articles used for distribution and treatment and SCADA).
  - (3)      Field Services Manager – (Construction and field equipment and materials, contract change orders).
  - (4)      Chief Plant Operator – (Articles used for treatment).
  - (5)      Senior Engineer – (Contract services, contract change orders).
  - (6)      Senior Accountant – (Contract services, articles related to office equipment and supplies).



- (7) Field Supervisors – (Articles such as field equipment and materials).
- (8) Warehouse Supervisor – (Warehouse related articles).
- d. Maintenance. As defined in Public Contract Code § 22002, Maintenance includes all of the following: (1) routine, recurring, and usual work for the preservation or protection of any publicly owned or publicly operated facility for its intended purposes (2) minor repainting (3) resurfacing of streets and highways at less than one inch (4) landscape maintenance, including mowing, watering, trimming, pruning, planting, replacement of plants, and servicing of irrigation and sprinkler systems (5) work performed to keep, operate, and maintain publicly owned water, power, or waste disposal systems, including, but not limited to, dams, reservoirs, powerplants, and electrical transmission lines of 230,000 volts and higher.
- e. Open Purchase Order. A purchase order for Articles which is effective for a specified period of time, not more than annually, and within the same budget year, i.e., office supplies and auto parts.
- f. Professional Services. Professional services, such as services involving provision of a report, study, plan, design, specification, document, program, advice, recommendation, analysis, review, inspection, investigation, audit, brokering or representation of the District before or in dealings with another party, or any other services which require a special skill or expertise of a professional, scientific or technical nature. Professional Services include architectural, landscape architectural, engineering, environmental, land surveying, construction project management services. Professional Services also include legal, financial, accounting, and planning services.
- g. Public Project. Defined in Cal. Public Contract Code § 22002, means any of the following: (1) Construction, reconstruction, erection, alteration, renovation, improvement, demolition, and repair work involving any publicly owned, leased, or operated facility and (2) Painting or repainting of any publicly owned, leased, or operated facility.

Sec. 5.5 Procedures for the Purchase of Public Projects, Maintenance, and Articles

- a. Purchase Procedures for Public Projects, Maintenance, and Articles in the Amount of \$45,000 or Less (“Small Purchase Procedures”).

The General Manager or Designee may make purchases of Public Projects, Maintenance, and Articles in an amount of \$45,000 or less, in accordance with the following Small Purchase Procedures, which the Board has imposed for such purchases, in the interests of sound business judgment.

- (1) Purchases of \$10,000 or more shall be made after obtaining three (3) written quotations. Purchases under \$10,000 shall be purchased in the most prudent and economical manner possible, but do not require multiple competitive quotations.
- (2) The requirement for three (3) quotations is not required in those cases where the Board has approved the purchase as a “standardized item” such as meters, or for Open Purchase Orders as provided below.
- (3) Small Purchase Procedures specific to Articles. All purchases shall be made by purchase order after a properly authorized Purchase Order Requisition (POR) has been completed, signed and forwarded in the required manner. The only exceptions to this requirement are purchases made under a pre-existing Open Purchase Order, purchase of small routine items from suppliers with open purchase order or accounts, or purchases made during emergency. The purchase order must indicate the name of the suggested vendor and an exact description and price of each Article. Shipping charges, if any, and applicable taxes must also be included in the total price. The purchase order shall be reviewed and signed by the General Manager or Designee.

Open Purchase Orders shall generally be utilized for the purchase of repetitive need, low-valued Articles or for the purchase of Articles (such as automotive supplies) which must be available on short notice. Open Purchase Orders shall not be utilized as a substitute for the normal requisition and purchase order process described in this section. Open Purchase Orders may be written for a single class of consumable Articles i.e., office supplies, without listing specific, exact descriptions of each Article, but not to exceed the authority listed above and cannot span a period of time which includes more than one fiscal year.

- (4) Small Purchase Procedures specific to Public Projects and Maintenance. All purchases shall be made by written contract. Any such contracts shall be awarded on the basis of price and such other criteria established by the General Manager or Designee, as may be in the best interest of the District, in light of the type of work involved. Contracts for Public Projects shall require the successful bidder to execute a bond, in a form approved by the Board, for the faithful performance of the contract. Additionally if the contract exceeds \$25,000 and involves erection, construction, alteration, repair or improvement of any public structure, building, road or other public improvement of any kind, the successful bidder shall execute a payment bond, as required by the provisions of the California Civil Code.
- (5) Petty cash. Occasionally purchases of minor items may be required. Payments for such items may be authorized from petty cash funds by the General Manager or Designee. In no case will approval exceed \$50.00.

- (6) Quote information shall be retained until completion of the annual audit for the fiscal year in which purchased, or as otherwise established in the District's Records Retention Schedule.
  - (7) Nothing in these Small Purchase Procedures shall prevent the General Manager, or Designee, from obtaining multiple quotations or from implementing the Informal Bid Procedures or Formal Bid Procedures if it is in the best economic interests of the District to do so. This judgment shall be made in the sole discretion of the General Manager or Designee.
  - (8) Nothing in these Small Purchase Procedures shall prohibit the District from doing or causing to be done directly by the District, and without any contract, any or all work necessary or proper in or about the making of all current and ordinary repairs or in or about current and ordinary upkeep or maintenance.
  - (8) Under no circumstances shall purchases be split or separated into multiple purchases in order to avoid the Small Purchase Procedures, Informal Bid Procedures and/or Formal Bid Procedures set forth herein
- b. Purchase Procedures for Public Projects, Maintenance, and Articles in Excess of \$45,000 and \$175,000 or Less ("Informal Bid Procedures").

In accordance with Public Contract Code Section 22034, the District adopts the following Informal Bid Procedures, applicable to purchases of Public Projects, Maintenance, and Articles in excess of \$45,000 and \$175,000 or less. Contract award shall be made by the Board.

- (1) The District shall maintain a list of qualified contractors, identified according to categories of work. Minimum criteria for development and maintenance of the contractors list shall be as required by the Commission.
- (2) All contractors on the list for the category of work being bid or all construction trade journals pursuant to in Public Contract Code Section 22036, or both all contractors on the list for the category of work being bid and all construction trade journals pursuant to in Public Contract Code Section 22036, shall be mailed, faxed or emailed, a notice inviting informal bids unless the product or service is proprietary.
- (3) All delivery of notices inviting informal bids to contractors and construction trade journals shall be completed not less than 10 calendar days before bids are due. The notice inviting informal bids may also be published in in a newspaper of general circulation.

- (4) The notice inviting informal bids shall describe the project in general terms and how to obtain more detailed information about the project, and state the time and place for the submission of bids.
- (5) If all bids received are in excess of \$175,000, the Board may, by adoption of a resolution by a four-fifths (4/5) vote, award the contract, at one \$187,500 or less, to the lowest responsible bidder, if it determines the cost estimate of the District is reasonable.
- (6) If awarded, a contract will be awarded to the lowest responsible bidder, consistent with the quality and delivery requirements.
- (7) All contracts for Public Projects shall require the successful bidder to execute a bond, in a form approved by the Board, for the faithful performance of the contract. Additionally if the contract involves erection, construction, alteration, repair or improvement of any public structure, building, road or other public improvement of any kind, the successful bidder shall execute a payment bond, as required by the provisions of the California Civil Code.
- (8) The Board shall have the right to reject all or any of the bids received.

c. Purchase Procedures for Public Projects, Maintenance, and Articles in Excess of \$175,000 (“Formal Bid Procedures”).

Purchases of Public Projects, Maintenance, and Articles in an amount exceeding \$175,000 shall be procured pursuant to the following Formal Bid Procedures. Contract award shall be made by the Board. Additionally, all plans and specifications for Public Projects shall be adopted by the Board or General Manager/ Designee.

- (1) In accordance with Public Contract Code Section 22037, a notice inviting formal bids shall be published in a newspaper of general circulation, printed and published, at least 14 calendar days before the date of opening the bids, in the jurisdiction of the District and any such other newspaper publications deemed appropriate by the General Manager or Designee. Notice inviting formal bids shall state the time and place for the receiving and opening of sealed bids and distinctly describe the project.

If applicable, the notice inviting formal bids shall also be sent electronically, if available, by either facsimile or electronic mail and mailed to all construction trade journals. The notice shall be sent at least 15 calendar days before the date of opening the bids.

- (2) All bids for shall be presented under sealed cover. If awarded, a contract will be awarded to the responsible bidder who submits the lowest responsive bid.
- (3) All bids for Public Projects shall be accompanied by one of the following forms of bidder's security:
  - i. Cash
  - ii. A cashier's check made payable to the District
  - iii. A certified check made payable to the District
  - iv. A bidder's bond executed by an admitted surety insurer made payable to the District in the form provided by the District

Upon an award to the lowest bidder, the security of an unsuccessful bidder shall be returned in a reasonable period of time, but in no event shall that security be held by the District beyond 60 days from the time the award is made.

- (4) All contracts for Public Projects shall require the successful bidder to execute a bond, in a form approved by the Board, for the faithful performance of the contract. Additionally if the contract involves erection, construction, alteration, repair or improvement of any public structure, building, road or other public improvement of any kind, the successful bidder shall execute a payment bond, as required by the provisions of the California Civil Code.
  - (5) The Board shall have the right to reject all or any of the bids received.
- d. Nothing in this Section shall preclude the District from utilizing the design-build project delivery method where authorized by and in accordance with the provisions and requirements set forth in California Public Contract Code Section 22160 et seq., as it may be amended from time to time.

Sec. 5.6 Procedures for Procurement of Professional Services.

- a. Pursuant to California Government Code Section 4526 et seq., the District shall secure professional services on the basis of demonstrated competence and on the professional qualifications necessary for the satisfactory performance of the services required. When specific technical expertise or experience is required, the District may negotiate the scope and fee for these services with an individual firm with this specific expertise.
- b. The District may, for procurement of architectural, landscape architectural, engineering, environmental, land surveying, and construction management services, utilize the Qualification-Based Selection procedures adopted by the

Architects and Engineers Conference Committee of California, as deemed appropriate by the General Manager or Designee.

- c. If the value of the services are estimated to be \$45,000 or more, the District shall issue a formal Request for Proposals for the services. Additionally, if deemed in the best interests of the District as determined by the General Manager or Designee, the District may first issue a Request for Qualifications to solicit firms with the necessary qualifications for the services.
- d. If the value of the services are estimated to be less than \$45,000, where practical, three proposals shall be obtained unless the General Manager or Designee deems otherwise appropriate.
- e. Award of Professional Services Contracts may be made by the General Manager for contracts in the amount of \$45,000 or less. Contracts in excess of \$45,000 shall be awarded by the Board.
- f. The contract amendment procedures outlined in this Article apply to Professional Services Contracts.

Sec. 5.7      Prequalification.

The District may prequalify contractors, pursuant to the provisions and requirements of California Public Contract Code Section 20101, as determined appropriate in the reasonable discretion of the General Manager or District Engineer. Prequalification shall be through a uniform system of rating bidders on the basis of completed questionnaires and financial statements in a form specified by the Board. The District may accordingly limit bids or proposals it receives to those contractors who are prequalified.

Sec. 5.8      Emergencies.

California Public Contract Code Section 22050 authorizes special contracting procedures in cases of “emergency.” An “emergency” for purposes of Section 22050 is defined as a sudden, unexpected occurrence that poses a clear and imminent danger, requiring immediate action to prevent or mitigate the loss or impairment of life, health, property, or essential public services.

In the case of an emergency, as defined herein, the General Manager or Designee, may repair or replace a public facility, take any directly related and immediate action required by the emergency, and procure the necessary equipment, services, and supplies for those purposes, without giving notice for bids to let contracts. The General Manager, or Designee, must report to the Board at its next meeting required pursuant to this Section 5.8, the reasons justifying why the emergency will not permit a delay resulting

from a competitive solicitation for bids and why the action is necessary to respond to the emergency.

If the General Manager or Designee, orders any action specified herein, the Board shall initially review the emergency action not later than seven days after the action, or at its next regularly scheduled meeting if that meeting will occur not later than 14 days after the action, and at least at every regularly scheduled meeting thereafter until the action is terminated, to determine, by a four-fifths vote, that there is a need to continue the action, unless the General Manager or Designee, has terminated that action prior to the Board reviewing the emergency action and making a determination. When the Board reviews the emergency action, it shall terminate the action at the earliest possible date that conditions warrant so that the remainder of the emergency action may be completed by giving notice for bids to let contracts.

Sec. 5.9 Exceptions to Procurement Requirements.

a. Sole Source Exception.

Notwithstanding any provision in this Article 5, the procurement requirements set out in this Article 5 shall not apply to the procurement of Articles, Professional Services, Public Projects, or Maintenance that can only be obtained from one supplier or contractor and for which obtaining quotes or bids is therefore impossible or not in the public interest, such that no competitive advantage can be gained by soliciting quotes or bids. Sole source contracts or agreements up to \$45,000 may be procured by the General Manager or Designee. The Board must approve any source contracts or agreements of \$45,000 or more.

b. Purchases when Price Controlled by an Official Rate-Making Body.

Whether approved by the General Manager or Designee, or the Board, the District is authorized to procure services or Articles without quotation or bid if the price is controlled by an official rate-making body such as is the case with wholesale water from SDCWA, electricity, gas and telephone, and the services are provided for in the operating budget.

Sec. 5.10 Local Procurements.

- a. It is the District's policy to encourage local businesses to provide goods and services to the District in order to maintain a healthy local economy, to increase local competition, and to lower core costs of goods and services. Local preference for the procurement of eligible contracts may be allowed, so long as it is not otherwise prohibited by funding sources, by providing a 5% local preference where the purchase or contracts with a respective local vendor or business during any fiscal year do not exceed \$45,000. In order to qualify for this local preference, a vendor or business must either (a) be a District rate payer in good standing for the

past six months, or (b) receive District utility services at its business location for the past six months, paid by a third party.

- b. Eligible procurements include those contracts which are not otherwise subject to competitive bidding, including contracts for the following:
  - (1) Purchases of Public Projects, Maintenance, and Articles in the amount of \$45,000 or less, pursuant to Section 5.5(a).

Sec. 5.11 Sale of Surplus Property/Equipment and Scrap Metal.

- a. Surplus Property/Equipment. When it has been determined by the General Manager that equipment is no longer appropriate because of capability, size, age, etc., to fulfill the District's mission or if a particular piece of equipment is more costly to maintain than to replace, the item will be disposed of through the next scheduled San Diego County auction. Should property become surplus through obsolescence or through a change in operating methodology, the excess property will be disposed of, as determined by District staff, as follows:
  - (1) To other public agencies on a bid basis;
  - (2) San Diego County Auction, or
  - (3) Internet-based inline auction services.
- b. Scrap Metal. The scrap metal which accumulates through the replacing of damaged and/or unserviceable items in the course of District operations, shall be sold as scrap to local scrap dealers at prevailing rates. Sales receipts shall be miscellaneous revenues of the District.

Sec. 5.12 Use of District Credit Card.

- a. There are certain transactions that are more efficient using a credit card transaction. Examples include small purchases that are lower cost on-line, travel arrangements, registration for training and other similar services.
- b. The credit card shall never be used to circumvent established competitive purchasing procedures. The credit card is prohibited from being used to purchase items for personal use under all circumstances. Personal use of the credit card will result in disciplinary action.
- c. Authorized cardholders and credit card use shall be per the District Credit Card Users Guide as approved by the General Manager.

Sec. 5.13 Contract Amendment Procedures.



As delegated by the Board of Directors of the District pursuant to the provisions of the Public Utility District Act, the General Manager is authorized to issue amendments to contracts as follows:

- a. A purchase order or contract may be amended by the issuance of a change order or amendment, provided the change which is the subject of the change order or amendment is reasonably related to the scope of the original contract. The General Manager may issue a change order or amendment which results in a total contract price of \$45,000.00 or less. The General Manager may request approval authority from the Board to issue contract amendments for up to 10% of the total contract value for specific projects with an initial contract value of greater than \$45,000.
- b. When the cumulative sum of amendments to a contract would exceed the limits in (a) above, a report of such amendments will be presented to the Board at its next meeting. Upon acceptance of the amendments by the Board, the General Manager shall have additional authorization to issue amendments as if the original contract amount were the total of the original amount and all accepted amendments.

**ARTICLE 14 (Renumbered as  
Article 5 by Resolution 5006)**

Sec. 14.7 - Rev. 4/95  
Sec. 14.10 - Rev. 3/96  
Sec. 14.5(a), 14.6(a) & (d),  
14.7(d) - Rev. 6/99  
Sec. 14.11 - Added 10/05  
Sec. 14.4e(2), 14.10(c) &  
14.12(g) - Rev. 6/06  
Sec. 14.5(g) - Rev. 8/08  
Sec. 14.4(e), Rev 01/09  
Secs. 14.4(e)1,3,4,5,(f);  
14.5(a)(d); 14.6(c)(d); 14.7(d);  
14.9(b); 14.11(c) - Rev. 2/10  
Add Sec. 14.12 - Rev. 2/11  
Secs. 14.4; 14.9 - Rev. 1/13  
Secs. 14.4; 14.13 - Rev. 7/13  
Sec. 14.4 - Rev. 5/15  
Sec. 14.4(f), 14.9(c) - Rev. 1/16  
All Secs. Repealed and Replaced  
- Rev. 6/17  
Sec. 14.4 - Rev. 5/19

## **Article 6. Budget and Fund Management**

### **Sec. 6.1 District's Annual Budget.**

Preparation of the District Budget is directed by the Assistant General Manager/CFO. Working with the Fiscal Policy and Insurance Committee the General Managers develops annual financial goals and objectives for the budget in February. A first preliminary Budget is presented to the Committee/Board of Directors and public in April and a second preliminary Budget in May. The final Budget is presented in June for adoption, along with a resolution adopting a tax rate for Bonded Indebtedness.

The budgeting process is intended to create a transparent process that enables the Board of Directors to estimate the Districts revenues and expenses including employee compensation arising from negotiations and changes in other costs of operations.

#### **6.1.1 Annual Budget Resolution.**

The Board shall approve an annual budget resolution that establishes the total appropriation for the fiscal year based on the following budget categories:

1. Administration, operations, and maintenance
2. Water purchases and contingencies
3. Capital improvements and equipment
4. Revenue Bonds, State Revolving Fund, interest, and principal
5. Established annual Liquidity Fund level

In addition, the budget resolution shall identify any anticipated net withdrawal of District reserves for the Fiscal Year. Any unanticipated net withdrawal of District reserves shall be a separate board action. Any withdrawal of funds from long-term investments, as shown in the District's Treasurer's Report, shall require prior Board approval.

Any spending above the established appropriations or additional withdrawal of reserves shall require Board approval. As part of the annual budget process, the Board will review and approve the District's liquidity fund level.

### **Sec. 6.2 Treasurer's Fund.**

The Treasurer's Fund is established primarily to account for all District cash and investments and also to record detailed accounting for fringe benefits. Revenues are obtained from a budgeted mark-up on District labor. Revenue and Expense accounts in this fund are closed to the Utility fund annually.

### **Sec. 6.3 General Fund.**

The General Fund shall consist of accounts for property tax revenues and appropriations to other funds as determined by the Board.

### **Sec. 6.4 Utility Funds.**

The Utility Funds consists of three separate funds reflecting the operating departments of Water, Wastewater and Recycled Water. The funds reflect the revenues from water sales, monthly service charges and other recurring fees and all expenses, including Operating and Maintenance (O&M) and General & Administrative (G&A).

Sec. 6.5      Capital Funds.

The Capital Funds consists of all Property, Plant and Equipment and the expenditures as well as revenues from Capital Improvement Charges that are dedicated/restricted to capital expenditures. All use of revenues in the Capital Funds is restricted to capital investments, which includes capital assets as defined by the District's accounting policy and debt service. Sources of funding and expenditures for capital assets are maintained in three separate funds:

Water – all capital assets associated with the water treatment and distribution system; all administrative buildings and equipment; and all construction equipment and vehicles.

Wastewater – all capital assets associated with treatment facilities and the wastewater collection system.

Recycled Water – all capital assets associated with the recycled water facilities and the recycled water distribution system.

Sec. 6.6      Equipment Fund.

The Equipment Fund consists of all expenses for field equipment operations, maintenance, repair and replacement. Revenues are obtained from a budgeted mark-up on District labor. Revenue and expenses are closed to the Utility fund annually.

Sec. 6.7      Debt Service Funds.

Debt Service funds shall be established to account for General Obligation Bonds, Certificates of Participation, or other indebtedness which the District may incur for construction, completion, or acquisition of works, for the treatment, storage and distribution of water and water rights, including dams, reservoirs, storage tanks, treatment facilities, pipes, pumping equipment, and all necessary equipment and property therefor. The funds shall record annual transactions showing source of revenue, and both interest and principal payments.

Sec. 6.8      Appropriated Fund Balances.

Appropriated Fund Balances shall be established to provide adequate funding to meet the District's short term and long term plans and commitments; to minimize adverse annual and multi-year budgetary impacts from unanticipated expenditures; and to preserve the financial stability of the District against present and future uncertainties in an ever-changing environment. The following Appropriated Fund Balances will be established and maintained.

6.8.1      Utility Funds Appropriated Fund Balances.

1.      Water.

- a)      Working Capital. To be established and maintained at a level of three months operating and maintenance expenses including water purchases.

b) Santa Margarita Debt Payment Fund. To prevent “spikes” and mid-year changes in rates because of net revenue shortfalls due to weather conditions, state or federal legislation or other future uncertainties. The target level is set equal to 2-years of debt service payments on the Santa Margarita Conjunctive Use Project financing.

2. Wastewater.

a) Working Capital. To be established and maintained at a level of three months operating and maintenance expenses.

b) Rate Stabilization Fund. To promote smooth and predictable rates and charges a Rate Stabilization Fund is established with a target of level equal to 10% of annual revenues.

3. Recycled Water.

a) Working Capital. To be established at three months operating and maintenance expenses.

6.8.2 Utility Capital Funds Appropriated Fund Balances.

1. Water Capital Fund.

The primary source of funds are the Water and Pumping Capital Improvement charges, annexation fees, connection fees and meter fees. Target fund balance is set to the equivalent of 3-year average expenditures on recurring capital projects (*i.e.* pipeline renewal/replacement).

a) Funds related to the 1958 Annexation and the DeLuz Service Area bond proceeds are tracked separately in the fund.

2. Wastewater Capital Fund.

The primary source of funds are Wastewater Capital Improvement Charges, connection fees and meter fees. Target fund balance is set to the equivalent of 3-year average expenditures on recurring capital projects (*i.e.* pipeline renewal/replacement).

3. Recycled Water Capital Fund.

Target fund balance is set to the equivalent of 3-year average expenditures on recurring capital projects (*i.e.* pipeline renewal/replacement).

6.8.3 Debt Service Funds.

Each borrowing activity is maintained within a separate Debt Service fund. Some indentures require the establishment of a reserve fund and the District must comply with any creditor imposed requirements. Since sources of funding to repay each debt instrument varies, the possibility of that inflow being interrupted is

likely/possible with different issues in differing circumstances. Because of the possibility of this interruption, each Debt Service Fund should establish an Appropriated Fund Balance equal to the next year's total debt service (principal and interest).

Sec. 6.9 Petty Cash.

The responsibility for and the accountability for the petty cash fund is assigned to the Assistant General Manager/CFO and/or the Accountant. The fund at all times will total \$400.00 in cash and disbursement receipts. When an employee requires reimbursement, not-to-exceed \$50.00, for an out-of-pocket District expense, a petty cash voucher is filled out and the receipts for purchases attached.

Reimbursement will not be made from the petty cash fund without the immediate supervisor's approval on the petty cash voucher and receipts attached thereto.

During the planned absence of either the Assistant General Manager/CFO or Accountant, the Supervising Accounting Assistant will be authorized to make petty cash reimbursements. Prior to assumption of these duties, cash in the fund will be counted and verified by both the Assistant General Manager/CFO and Accountant.

Periodic audits will be performed as required by District management or the Auditor. Checks drawn to replace the disbursement will be processed in the same manner as any other invoice paid by the District.

<b>ARTICLE</b>	<b>15</b>
<b>(Renumbered</b>	<b>as</b>
<b>Article 6</b>	<b>by</b>
<b>Resolution 5006)</b>	
Sec. 15.8 - Rev.74/97	
Sec. 15.4 & 15.5 – Rev. 4/03	
Sec. 15.8 added 4/03	
Sec. 15.1 & 15.9 – Rev. 6/06	
Sec. 15.9 – Rev. 8/08	
Sec. 15.6 – Rev. 9/09	
Sec. 15.8.1 – Rev. 12/09	
Secs. 15.1, 15.5, 15.8.1, 15.8.2, 15.8.4, 15.9 – Rev. 1/18	
Secs. 15.1.1, 15.8.1 – Rev. 2/19	
Sec. 15.1.1 – Rev. 4/19	
Sec. 15.1 – Rev. 7/19	

**Article 7-A. Insurance Claims Handling Procedures (JPIA)**

Sec. 7A.1 General.

The District is a member of the Association of California Water Agencies/Joint Powers Insurance Authority (ACWA/JPIA) and obtains its general liability and real property insurances from them. It is the policy of JPIA to see that all liability claims made against its member districts are investigated and settled expeditiously. Decisions regarding the disposition of a claim shall be based on the merits of that claim; including the legal liabilities involved, the nature and extent of damage, and the coverage afforded by and/or through JPIA. It is the policy of JPIA to pay only those claims for which member districts have legal liability.

Sec. 7A.2 General Handling Procedures.

Before commencing a suit for money or damages against the District, the claimant must present a written claim to the District and allow it to act upon the claim. The claim must contain the name and address of claimant, P.O. box to which the person presenting a claim desires notices to be sent, date, place and circumstances of the occurrence, description of injury, damages, or losses so far as they are known, names(s) of District employee(s) causing injury or damage, the amount claimed and the basis for computation if under \$10,000 and signature of the claimant or representative.

A claim for death, personal injury, or damage to personal property must be presented within six (6) months of the accrual of the cause of action. Exceptions to the six month rule are claims for inverse condemnation, violations of federal rights, contract violations, and damage to real property.

7A.2.1 Rejection of Sufficient and Timely Claims.

Only those claims with proper and sufficient contents and presented in a timely fashion may be rejected by the Board of Directors. If a claim is rejected in writing within 45 days of presentation and the rejection by the Board is in the prescribed manner, the claimant has only six (6) months in which to file suit. The claimant may also contact JPIA directly and be assigned a claims adjuster to handle their claim after the Board's rejection.

If a claim is not rejected in writing within 45 days of presentation, the claim is deemed rejected by operation of law on the 45th day. The resulting problem, however, is that the claimant then has two (2) years in which to file suit. Therefore, written claim rejections are recommended where claims are to be rejected.

7A.2.2 Rejection of Insufficient and Late Claims.

An insufficient claim should not be rejected. The District must notify the claimant in writing with 20 days of presentation that the claim is insufficient and state the particulars, or the District waives the insufficiency and cannot claim insufficiency as a defense.

7A.2.3 Late Claims.

If a claim is not presented in a timely fashion, then the claimant must present an application to present a late claim within one year of accrual of cause of action, and must have a written claim attached and must set forth the reason for delay. Claims filed late, if not accompanied by an application for leave to file a late claim, should be rejected specifically because they are late. They should not be considered on their merits.

The District shall grant the application where the failure to present a claim was by excusable neglect, mistake or the like, and the District was not prejudiced, or the claimant was a minor during all of the time period, or physical or mental incapacitation or death was the cause.

The District may deny any application if it is not excused. The denial must be in writing, and must advise the claimant that he has only six (6) months to take the matter to court. The court can choose to allow the filing of the late claim on the same grounds as in acceptance of application for late claim. The denial for the application has nothing to do with the validity of the claim. It is not a rejection of the claim or its merits. It means only that the claim was not properly presented.

Sec. 7A.3 Small Claims Settlement Option.

The District has the option of settling or denying claims arising out of any occurrence covered by the JPIA Liability Program which meets all of the following conditions:

- (a) All claims arising out of the occurrence are for property damage only.
- (b) No claim arising out of the occurrence has any apparent potential for related bodily injury allegations.
- (c) The estimated settlement value for all claims arising out of the occurrence does not exceed the District's Self-Insured Retention per occurrence.
- (d) The claim settlement or denial arising out of the occurrence can be concluded within 60 days of when the District became aware that the claim existed.
- (e) A settlement is to be made only when the claim being considered is determined to be based upon liability covered by the JPIA Liability Program.

ARTICLE 16 (Renumbered as Article 7A by Resolution 5006)
Renamed Article 16A – 1/22/07

## **Article 7-B. Insurance Claims Handling Procedures (District-Government Code 905)**

### **Sec. 7B.1 General.**

The liability and immunity of a public agency such as the District is governed by the Government Tort Claims Act set forth in Government Code Section 819 et seq. (the “Act”). Pursuant to the Act, an action for money or damages may not be maintained against the District unless a written claim has first been timely presented to the District and rejected in whole or in part (Government Code Section 905, 905.2, 945.4). Presentation of a claim, when required by law, is a mandatory prerequisite to bringing a legal action against the District, and,

Government Code Section 905 sets forth the rule regarding the presentation of claims and also provides an exemption from said requirement in certain cases including claims by the State or another public entity.

Government Code Section 935 permits the District to establish its own procedures to cover the presentation of those claims against it which are exempted by Section 905, as well as all other claims.

Pursuant to the authority contained in Section 935 of the Government Code, the following claims procedure is hereby established for claims against the District for money or damages that are not governed by any State law.

### **Sec. 7B.2 Claims Time Limitations.**

Notwithstanding the exemptions set forth in Section 905 of the Government Code, all claims against the district for damages or money, where a procedure for presenting such claims is not otherwise provided by State law, shall be presented within the time limitations and in the manner provided by Section 910, et seq. of the Government Code.

### **Sec. 7B.3 Claims Required.**

All claims against the District for money or damages not otherwise governed by the Government Claims Act, California Government Code Division 3.6, Sections 810 et seq., or another state law (hereinafter in this ordinance, “claims”) shall be presented within the time, and in the manner, prescribed by Part 3 of Division 3.6 of Title 1 of the California Government Code (commencing with Section 900 thereof) for the claims to which that Part applies by its own terms, as those provisions now exist or shall hereafter be amended, and as further provided by this article.

### **Sec. 7B.4 Form of Claim.**

All claims shall be made in writing and verified by the claimant or by his or her guardian, conservator, executor or administrator. No claim may be filed on behalf of a class of persons unless verified by every member of that class as required by this section. In addition, all claims shall contain the information required by California Government Code Section 910.



Sec. 7B.5 Claim Prerequisite to Suit.

In accordance with California Government Code Sections 935(b) and 945.6, all claims shall be presented as provided in this section and acted upon by the District prior to the filing of any action on such claims and no such action may be maintained by a person who has not complied with the requirements of Sec. 7B.3 of this section.

Sec. 7B.6 Suit.

Any action brought against the District upon any claim or demand shall conform to the requirements of Sections 940-949 of the California Government Code. Any action brought against any employee of the District shall conform to the requirements of Section 950-951 of the California Government Code.

Sec. 7B.7 Severability.

Should any provision of this article, or its application to any person or circumstance, be determined by a court of competent jurisdiction to be unlawful, unenforceable or otherwise void, that determination shall have no effect on any other provision of this article or the application of this article to any other person or circumstance and, to that end, the provisions hereof are severable.

<p><b>ARTICLE 16B</b> (Renumbered as Article 7B by Resolution 5006)</p> <p>New Article added – 1/22/07</p>
--

**Article 8. District Inspections by a Regulatory Agency**

Sec. 8.1 General.

It is the policy of Fallbrook Public Utility District (FPUD) to permit inspections by representatives of county, state and federal regulatory agencies without notice or court order and to cooperate fully. Such inspections shall be accomplished in accordance with the procedures outlined below.

Sec. 8.2 Purpose.

In order to comply with FPUD's Mission Statement to continue to provide for the community of Fallbrook now and in the future:

- (a) A reliable supply and delivery of high quality retail potable water and service, and
- (b) the collection and disposal of wastewater and solids consistent with the optimal use of recycled water,
- (c) use of the most efficient and economical means possible while emphasizing the importance of making customer satisfaction the top priority of operations,

these procedures are designed to provide guidance to District employees to effectively respond to and assist with, regulatory agency compliance inspections. These procedures were developed to provide guidance for District personnel in complying with regulatory inspections without impairing the functioning of District Staff.

Sec. 8.3 Scope.

These procedures shall apply to all FPUD employees who may interact with regulatory agency compliance inspectors in the course and scope of their work. Members of management and employees directly involved in an inspection shall be guided by the examples following.

Sec. 8.4 Responsibilities.

The Engineering Department Head, or his designee, will be the initial contact for any regulatory agency compliance inspector. If no one is available, it will be arranged for the inspector to return at a later time.

If the inspector arrives unannounced, he/she will be asked to wait for the Engineering Department Head. If the Engineering Department Head is unavailable, an available member of management will meet with the inspector to explain the District's policy on unannounced inspections and will then make an appointment for that inspector with the Engineering Department Head or his designee. If the

inspection is of a regulatory nature that requires an inspection without prior notice, a member of management will accompany the inspector.

Sec. 8.5      Procedures.

Before an Inspection:

1. Upon arrival at any District workplace, the inspector will be asked to wait for the Engineering Department Head or his designated District representative. If the inspector contacts a District employee, the employee shall immediately notify their supervisor who will inform the Engineering Department Head. The inspector may be requested to meet with the Engineering Department Head or his representative at a specific location, such as the administrative offices.
2. If the Engineering Department Head or his designated District representative (herein known as the District representative) is not available in a reasonable time, 30 to 60 minutes, the inspector is to be informed of that fact. The inspector should be told that District policy requires the presence of a District representative during the inspection and that the inspection may not proceed without this individual. If no District representative is available, it should be politely suggested that the inspection take place another time or day.
3. The District representative will ask for an opening conference in an attempt to learn the basis for the inspection. The representative should try to limit the inspection to the purpose stated by the inspector.
4. During or upon completion of the opening conference, the inspector should ask consent to begin the inspection. The inspection will then commence in the presence of the District representative.

During the Inspection:

1. The District representative will accompany the inspector throughout the inspection. The representative should be courteous to the inspector and respond to questions only if authorized to do so. The inspector should be informed that the representative is not authorized to speak for the District. Answers should be direct and succinct. Do not volunteer irrelevant and unfavorable information.

*Under no circumstances is the representative, or any other employee, to guess or speculate when responding to questions of an inspector. The only acceptable answer is what the employee knows to be the facts. If the employee has no actual knowledge he should say so. Do not agree with statements made by the inspector, as they may be incorrect.*

2. Inspectors may take photographs, videos, and/or samples of the workplace. The District representative will take similar samples and photographs. The District representative should take notes of everything the inspector says and does, and the identity and summary of testimony of the employees interviewed.

After the Inspection:

1. Upon completion of the inspection, ask the inspector for a closing conference. At this conference ask if any citations will be issued and what regulatory guidelines will be cited. Also try to find out how the citations will be classified (general, serious, etc.). Do not argue with the inspector and do not admit to any violation of regulatory guidelines. It may be helpful to have additional management staff at the closing conference to ensure what the inspector says is fully understood.
2. If the inspector indicates that citations may be issued, call the inspecting agency's District office, that day, and schedule a meeting with the District Manager. The purpose of this meeting is to present your side of the facts and attempt to mitigate any potential citations. During the meeting advise the District Manager that the District is concerned and desires to mitigate and/or avoid reoccurrence.
3. When the inspection is completed, the District representative should meet with District management and District legal counsel. A report should be prepared listing all actions taken during the inspection, everything the inspector said and did, and include all photographs and samples. The report is confidential and copies of this report are not to be circulated.
4. Call JPIA Risk Management, 800/231-5742 and discuss the results of the inspection and the District's potential options.
5. If the District receives a citation(s) it will come by certified mail. If it is decided by management and legal counsel that the District is going to appeal the citation, the District usually has 15 days to file an appeal. Contact JPIA Risk Management and District legal counsel for assistance in appropriately filling out the appeal form. The completed appeal form should be filled out and returned via certified mail.
6. If the District has to appear at an appeal hearing, legal counsel should represent the District. Working with JPIA Risk Management in preparing for the hearing is also recommended.

<p><b>ARTICLE 17 (Renumbered as Article 8 by Resolution 5006)</b></p> <p>Sec. 17.10 – Rev. 4/95          Sec. 17.11 – Rev. 4/95          Sec. 17.12 – Rev. 4/95          Sec. 17.7 – Rev. 7/97          Sec. 17.13 &amp; 17.14 – Rev. 11/99          Sec. 17.5 – added ½          Sec. 17.16.4 &amp; 17.16.5 – Rev. 6/06          Secs. 17.7 to 17.15; 17.6 deleted – Rev. 1/11          All Secs. – Rev. 3/11</p>
--

**Article 9.**            **Annexations**

Sec. 9.1            **Incorporation by Reference.**

Ordinance Nos. 73, 92, 122, 226, and 248 are hereby incorporated into the Administrative Code and made a part hereof. Summaries of various provisions of these ordinances follow herein. Reference must be made to a particular ordinance for exact language and legal descriptions of property annexed. The above referenced ordinances refer to the following:

Ordinance No. 73	1950 Annexation
Ordinance No. 92	1958 Annexation
Ordinance No. 122	Airpark Annexation
Ordinance No. 226	Conditions of Service, Waterline Extensions
Ordinance No. 248	Water Service & Water Rates
Resolution No. 1732	Description of Land, Red Mountain Ranch
Resolution No. 1791	Red Mountain Ranch Annexation
Resolution of LAFCO	DeLuz Annexation 1/8/90
Resolution No. 10A	Board of Supervisors, DeLuz Annexation 6/13/90

Sec. 9.2            **General.**

Water Service will be provided to lands within FPUD only after the owner of each parcel to be served has paid an annexation fee. Annexation fees are established for the purpose of equalizing the proportionate obligations, expenditures, and costs of operation between the territory within the District and the territory to be annexed.

*Ordinance No. 92*

*Ordinance No. 226 and 248.*

Sec. 9.3            **Annexation Payments.**

Annexation payments made to the District will be deposited in and held in a special account and will be used by the District toward defraying the costs and expenses of:

- a) Payment of costs and expenses of the District in connection with or incidental to the annexation proceedings.
- b) Payment to the San Diego County Water Authority and Metropolitan Water District of any amounts established by each said Authority and said District in consenting to the concurrent annexation of said territory to said Authority and said District, to be levied as special taxes by said Authority and by said District.
- c) In lieu taxes, from date of Board's approval of annexation to date District taxes may be levied.
- d) Pipelines to service or facilitate service of water to the annexed lands.
- e) Storage facilities.

- f) Improvements in District's facilities to enable it to handle the larger operating load created by the annexation.
- g) Other capital improvements which the Board of Directors may determine would be beneficial to the annexed lands.

Annexed lands share fully in all District assets and liabilities and shall be subject to the same District taxes as the lands already in the District, including taxes for payment of the present bonded indebtedness and other outstanding obligations of the District.

All water rates, rentals, rules and regulations established and to be established by the District for water service and for water delivered by said District, irrespective of the source from which water comes, shall apply uniformly to lands in the annexed areas which have paid their service connection charges in full and to the land already within the District.  
*Ordinance No. 92*

Sec. 9.4      Conditions for Annexation.

All lands annexed shall be subject to easements for rights of way for District pipelines, power and phone lines and similar facilities used and to be used in connection with the District's operations, as may be required and determined necessary by the Board of Directors of said District, for installing, improving, repairing, replacing and maintaining such District facilities, which rights of way shall be furnished the District without claim or charge for compensation or damages. The District or its party will undertake to locate and maintain such facilities with as little injury as possible to the landowners property consistent with maintaining and operating an efficient system.

All existing operating policies of the District relating to water service and water delivery shall apply to and govern the annexed lands which have completed their service connection charges in full, uniformly with present District lands.

District's distribution pipelines to service the annexed lands will be laid along routes as determined by the District. Pipelines beyond District distribution lines or meters, must be installed, maintained and operated by owners.

Annexation to the District is and will be subject to the condition that the said territory shall also be annexed concurrently to the SDCWA and MWD and shall become and be subject to and be bound by all the terms and conditions fixed by said District and said

Authority respectively, for said annexation and annexation to the District shall become effective and binding only if and when said annexation also has become effective and binding as to the SDCWA and MWD and said lands have been included in and have become a part of the SDCWA and MWD.  
*Ordinance No. 92*

Sec. 9.5      1950 Annexation.

The 1950 annexation has all been paid into the District. The 1950 annexation was recorded August 1, 1950.  
*Ordinance No. 73.*

Sec. 9.6      1958 Annexation.

A petition for annexation to the Fallbrook Public Utility District of unincorporated contiguous territory was filed with the District by not less than 15% of the qualified electors residing in the territory and adopted on September 2, 1958.

In 1958, the District annexed 7,277 acres of land, mainly in the area across the Santa Margarita River, but also taking in all the little windows, which were within the original District boundary that had not paid their annexation fee. Prior to 1958, annexations were not voluntary, and therefore, there was no annexation fee charged at the time. Starting in 1958, a fee of \$250/acre rising to \$450/acre, which was reached in 1970, is a condition for receiving District water. Persons wishing to annex to the District must provide 1) certification of gross acreage by a licensed engineer or surveyor, 2) metes and bounds legal description, and 3) a plat map. (A recorded lot split map showing gross acreage provides all three requirements.)

At the option of the owner of land within the annexed area, service connection charges may be paid for a portion of a single ownership, at the rate of \$450/acre, subject to the following conditions:

- a) The portion of a single ownership so paid up shall consist of not less than 10 acres and shall be rectangular in shape with all four of its side boundaries parallel to Section lines, except sides which are property boundaries.
- b) Water service will not be provided for any portion of a single ownership unless service connection charges have been paid for all planted acreage within such single ownership.

The 1958 annexation was filed with the County Recorder on November 24, 1958.  
*Ordinance No. 92*

Sec. 9.7      Airpark Annexation.

In 1966, the Board annexed the Airpark property to the District. The maximum service connection charge of \$400 per gross acre was reached in 1975.  
*Ordinance No. 122.*

Sec. 9.8      Red Mountain Ranch Annexation.

In 1978, the District annexed 330 acres of Red Mountain Ranch. Water service connection charges (annexation) began at \$750/acre in 1980 and progressed to \$1,000/acre January 1, 1984. The District will not serve any parcel above the 1400 foot elevation level until such time as all water service connection charges have been paid on all such parcels within the annexed area. Two parcels, 108-010-39 and 40, have been granted a waiver from this agreement.  
*Resolution Nos. 1732 & 1791*

Sec. 9.9      DeLuz Annexation.

Formation of the Parent District of the DeLuz Heights MWD occurred on September 25, 1962 by the registered voters. The District then became a member agency of the San Diego County Water Authority on June 28, 1967, and the District Board of Directors established Improvement District No. 1 (I.D. #1) on March 11, 1969 which

consisted of approximately 8,970 acres. Subsequently, a joint petition was filed by 13 individual property owners requesting annexation of approximately 1,580 additional acres to I.D. #1. Improvement District No. 2 (I.D. #2) was formed by the Board of Directors on February 29, 1972 by a special election of individual property owners, which brought the total area to 10,687 acres.

Both I.D. #1 and #2 have coterminous boundaries and voter approved bonds in both areas were used for system improvements in the DeLuz Service Area.

On June 13, 1990, the San Diego County Board of Supervisors and the Local Agency Formation Commission approved the dissolution of DeLuz Heights MWD and its annexation to the Fallbrook Public Utility District, with approval from a majority of the voters. This reorganization included transfer of 12,000 acres of inhabited land, all tangible assets and monies, including cash on hand, monies due but not collected, and all accounts payable and any other obligations, effective June 30, 1990.

*LAFCO Resolution dated 1/8/90 & Board of Supervisors Resolution No. 10A dated 6/13/90.*

Sec. 9.10 Annexation/Detachments Between Adjacent Districts.

Requests for annexation/detachment between Districts is usually done because one District has a pipeline closer to the parcel wishing service, or the other District can provide more adequate service. These requests must be made to both Districts so that annexation/detachment is concurrent. The Board of Directors determines administrative fees, annexations fees, and/or pro-rated share of bonded indebtedness.  
*Ordinance No. 120*

Sec. 9.11 Partial Annexations.

If a landowner has more than 10 acres, he may pay for just 10 acres, provided he submits a legal description of the acreage to be annexed and served with District water. If he has less than 10 acres, he must pay in the whole piece. If more than 10 acres are planted, he must bring in all the planted area. In December of 1976, the Board of Directors authorized the General Manager and/or Secretary to accept a promissory note secured by a Deed of Trust, for annexation fees, if the payment of the fees causes a hardship on the property owner. The owner must pay 20% down with the balance, plus interest at the current general rate, on the promissory note. The balance is paid in four annual payments.

*This section revises Section 4 of Ordinance No. 92*

Sec. 9.12 DeLuz Service Area Annexations.

The fees charged for annexation of land to the DeLuz Service Area are as follows:

- a) Fee for annexation to the DeLuz Service Area, Parent District, is \$1,000.00, plus an acreage fee of \$100.00 per acre.
- b) Fee for annexation to the DeLuz Service Area Improvement Districts I and II is \$1,000.00, plus an acreage fee of \$350.00 per acre.
- c) Fee for annexation to the DeLuz Service Area Parent District and Improvement Districts I and II is \$1,000.00, plus an acreage fee of \$450.00 per acre.

9.12.1 Additional Costs.



The acreage fee shall increase as follows:

Five percent (5%) annually commencing July 1, 1988, and this increase shall be imposed on the first day of July of each calendar year thereafter.

All costs of preparing and processing an Environmental Impact Report, in the event one is required to process the annexation, shall be paid in full by the applicant.

All persons making application for annexation shall deposit with the District the required fees. In the event an environmental impact report is required to be prepared, the estimated cost of preparation and processing of the report shall be deposited with the District prior to the employment of the person or firm which will prepare the report. All additional fees required shall be deposited by the applicant before the District will file the Certificate of Completion to complete the annexation process. Any excess fees deposited will be returned to the applicant upon completion of the annexation.

*DeLuz Heights MWD Ordinance No. 10 (9/8/87)*

Sec. 9.13 Improvement District "S".

9.13.1 Annexation Fees and Costs.

The fees and costs for annexation of real property to the Fallbrook Public Utility District, Improvement District "S" after April 24, 2012, shall be those set forth below:

- a) Costs: The amount of Three Hundred Dollars (\$300.00) plus the current LAFCO processing fees shall be paid to the District at the time of application for processing annexation of real property to Improvement District "S".

The costs shall include any fees or costs required to be deposited with other governmental agencies in order to process the annexation. The District shall not approve the annexation until all required fees and costs have been deposited with the District.

- b) Fees: Effective April 24, 2012, an annexation fee of Nine Thousand Eight Hundred Sixty-Seven (\$9,867) dollars shall be charged for each equivalent dwelling unit permit for sewer service granted for service within the annexed territory at any time after the territory is annexed to the District. This fee shall be deposited with the application for issuance of a sewer service permit for service within the annexed territory.

9.13.2 Adjustment Review.

The fees and costs fixed by this Article of the Administrative Code shall be reviewed every five (5) years for the following

fiscal year and the fees and costs may be adjusted to be effective with the commencement of the fiscal year.

**ARTICLE 18 (Renumbered  
as Article 9 by Resolution  
5006)**

Sec. 18.11 – Rev. 2/93  
Sec. 18.1, 18.3-4 – Rev. 4/93  
Sec. 18.12 – Rev. 11/94  
Sec. 18.13 – Rev. 6/95  
Sec. 18.13.6 – Rev. 9/96  
Sec. 18.13.4 – Rev. 6/97  
Sec. 18.13.5 – Rev. 6/97  
Sec. 18.13.6(b) – Rev. 6/97  
Sec. 18.13.2,3,4,5,6(b) – Rev.  
9/98  
Sec. 18.13 – Rev. 4/12  
Secs. 18.2, 18.3 – Rev. 7/19

**Article 10.**

**Water Service Connections & Rules for Delivery of Water**

Sec. 10.1                    Definitions.

For the purpose of this Administrative Code and the regulation of water service by the Fallbrook Public Utility District, the following definitions are adopted:

The word "District", as used herein shall mean and refer to the Fallbrook Public Utility District of San Diego County, California. Fallbrook Service Area (FSA) will indicate that area known as Fallbrook Public Utility District prior to July 1, 1990. The DeLuz Service Area (DLSA) will indicate that area known as Improvement Districts I and II of DeLuz Heights Municipal Water District prior to July 1, 1990.

The word "Consumer", as used herein, shall mean and refer to every individual, corporation, association, farm, or place of business to whom or to which water is served by the District.

The word "Unit", as used herein, shall mean and refer to each of the following:

1. A single family residence.
2. A single business establishment.
3. A single farm.
4. One hotel or motel suite with bath and kitchen.
5. Two hotel or motel suites without kitchen but with private bath.
6. Four hotel or motel suites without private bath.
7. One trailer space.
8. In multi-family dwellings, each apartment with kitchen and bath.
9. Each dormitory or labor camp facility.
10. Nursing home.

The word "rates," as used herein, shall mean the compensation fixed by the Directors by Ordinance for water delivered to the consumer or for the cost of installing and maintaining meters, main line extensions and any and every appliance, fixture or connection used by said District in delivering water to said consumer.

The term "service connections", as used herein, shall designate the distribution system extension to the meter assembly and the connection to the consumer's line which shall previously have been provided to the location and to the specifications set by the District.

The term "Agricultural purposes", as used herein, shall mean the growing or raising, in conformity with recognized practices of husbandry, for the purposes of commerce, trade, or industry, of agricultural, horticultural, or floricultural products, and produced (1) for human consumption or for the market, or (2) for the feeding of fowl or livestock produced for human consumption or for the market, or (3) for the feeding of fowl or livestock for the purpose of obtaining their products for human consumption. Water used for agricultural purposes may be eligible for either the Commercial Agricultural Water Rate or Permanent Agricultural Water Rater (PSAWR) if they meet additional requirements outlined below.

The term "Commercial Agricultural", as used herein, shall mean the use of water through a single service connection for agricultural purposes without participation in the PSAWR

discount program, on land having an area of not less than one acre fully utilized for agricultural purposes.

The term "Domestic purposes", as used herein, shall mean the use of water for residential (up to and including two units) purposes and businesses that use water for incidental domestic purposes only. If a commercial agricultural parcel has a permanent residence, the first 5 units of water provided each month is considered for domestic purposes regardless of the number of residences on the property. If a PSAWR parcel has a permanent residence, the first 17 units of water provided each month is not eligible for the PSAWR program rate. Parcels using water for Agricultural purposes that are eligible for the commercial agricultural or PSAWR water rate programs will be classified as either Agricultural-Domestic with PSAWR Discount (AT) or Agricultural Commercial-Domestic (CB);

The term "Large Lot domestic purposes", as used herein, shall mean the use of water through a single service connection for residential (up to and including two units) purposes on parcels of one acre or more.

The term "Commercial purposes", as used herein, shall mean the use of water through a single service connection for the operation of the business or maintaining the landscaping of non-residential property.

The term "Government purposes", as used herein, shall mean the use of water through a single service connection for any political subdivision property.

The term "Multi-Unit purposes", as used herein, shall mean the use of water through a single service connection for master-metered residential housing of more than two living units.

The term "Standby Service", as used herein, shall mean a meter which has been locked at the request of the customer and which account balance remains current. Accounts may also be locked and placed on "standby service" in the event that the unpaid balance on the account becomes delinquent for a period of 90 days and/or if the District is made aware of foreclosure or vacancy of said property. A fee of \$50 to lock the meter and initiate standby service will be charged to the account and the account will be charged all applicable monthly standby charges.

The term "San Diego County Water Authority Permanent Special Agricultural Water Program" or "PSAWR", as used herein, shall mean the Program described in Section 10.11.

The term "Construction Meter Service", as used herein, shall mean the temporary use of water for construction from a meter installed on a fire hydrant.

The term "Temporary Ag Service", as used herein, shall mean the temporary use of water solely for the growing of annual crops through a temporary connection.

The term "Recycled Water System", as used herein, shall mean water that is defined in Title 22, Division 4, Chapter 3, Article 60301, paragraph 8, of the California Administrative Code and shall mean water which, as a result of filtration and disinfection of domestic wastewater, is suitable for a direct beneficial use or a controlled use that otherwise would not occur.

Sec. 10.2                    Remote Meter Agreements.

A Remote Meter Agreement is an agreement between the District and a consumer that a water meter will be installed at a location remote from the property to be served where the District does not intend to extend the District distribution system to abut the said property, and that the consumer is responsible for extending his own private line from the meter to his property and obtaining the permanent easements required for such extension.

Sec. 10.3                    Temporary Service Agreements.

A Temporary Service Agreement is a recorded agreement between the District and a consumer that a meter will be placed temporarily at a location remote from the property to be served, where the District intends, at some future date, to extend the District distribution system to abut the property described in the agreement, and that the consumer is responsible for extending his own temporary private line from the meter to his property, and obtaining whatever temporary easements are required for such extension. Such agreements shall establish the financial obligations of the consumer related to the future installation costs of the District's distribution system and the cost of relocation of the meter, and shall be binding upon the signatory and all successor owners of said property.

If the customer's obligation is to be secured with a promissory note and deed of trust, the terms will be based on the 10-year Treasury Bill rate plus 2%. Interest will be recalculated annually on the anniversary date of the recorded Trust Deed and will be compounded annually on the same anniversary date.

Failure to comply with the terms of the agreement shall be cause for termination of water service to said property and the basis for establishing a lien against the property for collection of any amounts due the District. Upon change of ownership, any parcel receiving water service under a Temporary Service Agreement will be required, as a condition of continued service, for the new owner to enter into a new Temporary Service Agreement with the District.

Sec. 10.4                    Engineering Fees.

Sec. 10.4.1                Plan Check Fees.

- A) Plan checks less than 500 lineal feet, water or sewer, \$500 each.
- B) Plan checks 500 lineal feet to 1,000 lineal feet, water or sewer, \$1,000 each.
- C) Plan checks greater than 1,000 lineal feet, \$1,000 each, plus .50 cents per lineal foot thereafter.

Sec. 10.4.2                Fees for District to Inspect Contractor Installed Facilities

- A) Water Meter Service Line Installation
  - ¾" to 2"                    5 hours @ \$106.31 = \$531.55
  - 3" and larger            9 hours @ \$106.31 = \$956.81
- B) Fire Hydrant Installation 9 hours @ \$106.31 = \$956.81
- C) Fire Service Installation 9 hours @ \$106.31 = \$956.81

If the sum of the inspection fees for a project is greater than \$3,000, the inspection will be done on a time and material basis and a deposit for the estimated cost will be paid prior to

start of construction. Inspection fees will be adjusted annually based on the Engineering News Record (ENR) Construction Cost Index (CCI) of February. Staff will report back to the Board no less than every five (5) years with analysis comparing current fees to calculated fees.

Sec. 10.5                    Rules for Service of Water.

The following rules for the service of water by the District to the consumer, either within or without the District, are hereby established:

All parcels desiring water must abut a District pipeline, and all meters will be located on the parcel being served unless the General Manager approves a Remote Meter Agreement, or the Board of Directors authorizes a Temporary Service Agreement subject to certain conditions as described in Section 10.3.

Each consumer desiring water furnished by the District shall furnish a plat of the property to be served, individually file a written application for such service, and in the form provided by the District, shall state the location, the number of acres served, the legal owner thereof, the purpose for which water is to be used and such other data regarding consumer's water production and use practices as required by the District. Based on the information provided, and verified by physical inspection if appropriate, each application will be assigned a user code: Agricultural with PSAWR Discount (AS); Agricultural Commercial (CA); Agricultural-Domestic with PSAWR Discount (AT); Agricultural Commercial-Domestic (CB); Domestic (D); Commercial (C), Government (G); or Multi-Unit (M) in accordance with the definitions provided in Section 19.1.

By making such application and upon approval thereof by the General Manager, or his designee, the application and the acceptance shall constitute a contract, the effect of which shall bind the applicant to pay all rates then or thereafter prescribed by the District for water service and to comply with all the rules and regulations with respect to service, a breach of any of which will authorize the District to discontinue water service immediately without notice or recourse and to levy such charges as otherwise provided for in this ordinance for resumption of service.

In addition, the effect of this contract shall be such as to bind the applicant to pay reasonable attorney's fees as fixed by the court where the District is required to take legal action to enforce collection of any charges incurred under this service.

The District reserves the right to determine the size and location of all service connections and may to that extent, where deemed for the best interests of the District, reduce the size, change the location or the pressure of the service connection without notice or recourse.

Sec. 10.6                    Meter and Service Line Installations.

Before any service connection with the water distribution system of the District is made, the District shall collect from the applicant who desires water service an installation charge as set forth below. A connection fee based on the demand factor shall be paid in addition to the installation charges and is described in Article 11 of this Administrative Code. Reclaimed meter and service line connections shall be capitalized as part of the project and not charged to the customer. Installation charges will be adjusted annually based on the ENR (Engineering News Record) Construction Cost Index (CCI) of

February. Staff will report back to the Board of Directors no less than every five (5) years with analysis comparing fees to actual costs.

<u>Meter Size</u>	<u>Meter and Service Line*</u>	<u>Meter Only on Existing Service Line</u>	<u>Service Line Only*</u>
3/4"	\$2784	\$468	\$2318
1"	\$2962	\$644	\$2318
1-1/2"	\$4017	\$1022	\$2995
2"	\$4818	\$1178	\$3640
3", 4" or 6"	Cost	Cost	Cost
Recycled, any size	No charge	No charge	No charge

\* If paving for a service line is less than or equal to 15 feet, there is an additional charge of \$1807 . If paving for a service line is greater than 15 feet and less than 30 feet, there is an additional charge of \$3615 . If County road inspection is required, there is an additional fee of \$1402.

Sec. 10.7 Meter Relocation Fees.

<u>Meter Size</u>	<u>Relocation and Service Line*</u>
3/4"	\$3,203
1"	\$3,364
1-1/2"	\$4,041
2"	\$4,645

\* If paving is required up to 30 feet, there is an additional fee of \$4746 . If County road inspection is required, there is an additional fee of \$1402.

Sec. 10.8 Connection/Capacity Fees.

A connection fee shall be paid at the time meter service is applied for, for all permanent service connections, which fee shall be in addition to the charges made for the actual cost of labor and materials necessary to make the physical connection to the water system. The capacity fee for the connection is based on the demand that could be placed on the District's water system by reason of the connection. The extent of demand will be determined on the basis of the size of the water meter necessary to provide the estimated quantity of water usage for the connection. The demand factor for each meter size shall be calculated on the basis of the rated capacity of each size of meter divided by the rated capacity of a 3/4" meter at a pressure of 40 pounds per square inch (20 gpm), hereinafter referred to as an "equivalent meter unit" (EMU) as defined by SDCWA. Connection/ capacity charges will be adjusted annually based on the ENR (Engineering News Record) Construction Cost Index (CCI) of February. Staff will report back to the Board of Directors no less than every five (5) years with analysis comparing current fees to calculated fees.

Effective January 1, 2020, the schedule of capacity fees based on the demand factor of each meter size shall be as follows:

<u>Meter Size</u>	<u>SDCWA Demand Factor (EMU)</u>	<u>Capacity Fee</u>
3/4"	1	\$5,778
1"	1.6	\$9,247
1-1/2"	3	\$17,336
2"	5.2	\$30,050
3"	9.6	\$55,477
4"	16.4	\$94,770
6"	30	\$173,365

The capacity charge for a meter size greater than 6 inches shall be a basic charge for one (1) EMU multiplied by one of the following factors:

8".....factor .....	52.0
10".....factor .....	78.0
12".....factor .....	132.0

Sec. 10.8.1 Removal of Meters.

An owner of a parcel who has a meter and is not required to have District water for their parcel can request to have their meter removed and discontinue service. A fee of \$100 will be charged for meter removal. Once the meter is removed, if service is later requested for the parcel, it will be subject to all the fees identified in Article 10, including installation and connection/capacity fees as if it is a new service.

The following procedure will be followed when discontinuation of service is requested:

1. The District will verify that the parcel does not have a residence or that another supply is available for the residence. If District water service is necessary as a health and safety concern for the residence then the meter cannot be removed.
2. The parcel owner shall sign a form that will be recorded on their deed indicating that water service was discontinued and re-establishing service will require payment of all fees similar to any other new water customer.
3. The District will remove the meter based on the fee established for meter removal.
4. The owner will be deleted from the District's customer database and no further monthly operations, capital improvement or standby fees will be charged to the parcel. The parcel will be subject to Water Availability Charges, unless the parcel owner requests deferral in accordance with Article 15.
5. If the water service is requested in the future for this parcel it will be similar to any other parcel without water service and subject to all necessary fees including installation and connection/capacity fees.

Sec. 10.8.2 Meter Testing Costs.

The District will provide meter testing upon request by ratepayers. A meter is considered accurate according to AWWA standards if it measures 98.5% to 101.5% of actual usage. If, after the customer's request for testing, the meter is determined to be accurate, the customer will be charged the following fee based on the size of the meter:



<u>Meter Size</u>	<u>Fee for testing</u>
3/4" – 1"	\$123
1 1/2" – 2"	\$165
Over 2"	To be tested by an outside agency at a cost to be determined on actual time and materials.

If the meter is inaccurate, the District will absorb the cost of the test and make the appropriate exchange or repair to said meter to AWWA standards of accuracy. These charges will be adjusted annually based on the ENR (Engineering News Record) Construction Cost Index (CCI) of February.

Sec. 10.8.3 Adjustment to Fees for Meters and Connections.

Service requests after advance payments for meters and connection fees shall be adjusted to the District's current schedule after six (6) months from the payment date(s).

Sec. 10.9 Credit for Connection Fees and Fees for Increased Meter Size.

Owners of parcels presently receiving water service through a District meter that subdivide their property and apply for additional meters to new legal parcels will be given credit for connection charges if they reduce their demand by requesting a smaller meter for their original service.

Owners of parcels presently receiving water service through a District meter that are not in the process of subdividing their land, but require a larger meter service connection due to a change in land use, shall pay a connection fee equal to the difference between connection fees for the old and new meters in accordance with the schedule in Sec. 10.8.

Sec. 10.10 San Diego County Water Authority Connection Fees.

The Board of Directors of the San Diego County Water Authority (SDCWA) announced an administrative adjustment to capacity charges on all meters purchased on or after January 1, 2020 within the boundaries of the SDCWA.

The System Capacity Charge for a meter size of one (1) inch or greater shall be the basic charge of \$5,312 multiplied by a Factor that is based upon additional meter capacity.

<u>Meter Size</u>	<u>Factor</u>	<u>System Capacity Charge</u>	<u>Water Treatment Capacity Charge</u>	<u>TOTAL</u>
Less than 1"	1.0	\$5,312	\$148	\$5,460
1"	1.6	\$8,499	\$237	\$8,736
1-1/2"	3.0	\$15,936	\$444	\$16,380
2"	5.2	\$27,622	\$770	\$28,392
3"	9.6	\$50,995	\$1421	\$52,416
4"	16.4	\$87,117	\$2,427	\$89,544
6"	30.0	\$159,360	\$4,440	\$163,800
8"	52.0	\$276,224	\$7,696	\$283,920
10"	78.0	\$414,336	\$11,544	\$425,880
12"	132.0	\$701,184	\$19,536	\$720,720

The System Capacity Charge is the cost for the conveyance and storage facilities necessary to operate the delivery system.

The Water Treatment Capacity Charge is the cost for the connection to the 50 MGD (million gallons per day) regional water treatment facility. The Water Treatment Capacity Charge is an additional charge of \$148 for each new meter of a size less than one inch and a corresponding increase for larger meters.

The member agency shall determine the size of the water meter to serve any property within its jurisdiction. In the event an agency calculates the water demand by the equivalent dwelling unit (EDU) method, the County Water Authority's capacity charge will be collected based on the size of meter actually installed to meet flow demand.

No capacity charge shall be imposed for a water meter permanently connected to a reclaimed water system and measuring reclaimed water. If a water user converts a water meter to permanently measure only reclaimed water, the capacity charge previously collected for the meter shall be refunded upon written request from the water user and verification by the member agency in which the water user is located that the meter is permanently connected to the reclaimed water supply and is measuring reclaimed water. The refund shall be in the amount of the capacity charge actually collected.

All claims for refund permitted shall be presented within one year of the date of the event justifying the refund.

Sec. 10.11 San Diego County Water Authority Permanent Special Agricultural Water Program Administration

Sec. 10.11.1 Purpose.

The San Diego County Water Authority Permanent Special Agricultural Water Program (PSAWR) provides discounted wholesale supply and treatment pricing for qualified agricultural users within its service area on the basis that participants receive non-firm, interruptible. This section of the District's Administrative Code establishes the rules and regulations for Administration of the SDCWA PSAWR within the Fallbrook Public Utility District (District).

Sec. 10.11.2 Qualification.

New eligible customers may sign up to receive the PSAWR Program water rate at any time during non-service limitation periods. Non-service limitation periods are when there are no service limitations imposed to PSAWR member agencies such as a cutback from Metropolitan or emergency situations. The qualifications for water use under the San Diego County Water Authority's (SDCWA) PSAWR program are as follows:

In accordance with the San Diego County Water Authority policies, including but not limited to the Permanent Special Agricultural Water Rate Program Handbook, Fallbrook Public Utility District and Owner acknowledge that to participate in the PSAWR water rate, agricultural customers must meet the following criteria:

1. Grow or raise – for commercial purposes – products of an agricultural, horticultural, or floricultural nature.

2. The Commercial Agricultural Operation must be included on one of the following lists (ONLY 1 REQUIRED):
  - Grower’s List
  - Active Certified Producers List
  - Organic Producers List
  - Regional Board General Agricultural Order Enrollment List

Sec. 10.11.3 Certification and Recertification.

Individuals applying for participation in the SDCWA PSAWR shall certify, a that they are the owner or authorized agent of the owner of the property to receive water under the SDCWA PSAWR and further certify that their respective water usage will meet the qualifications set forth in Section 10.11.2 and as modified from time to time by SDCWA. Upon submission and approval of the application for participation in the PSAWR, applicants shall be classified as either “Agricultural” or “Ag / Domestic”, and be eligible to receive the established water rate for the assigned classification. Participants may be subject to periodic re-certification as determined by the SDCWA, or the District.

Sec. 10.11.4 Acknowledgement.

Individuals participating in the PSAWR shall acknowledge that:

- a) Water received under the PSAWR is a non-firm, interruptible supply, subject to early and accelerated mandatory supply reduction as is from time to time determined necessary by MWD and/or the SDCWA.
- b) Water use under the PSAWR supply is subject to periodic data examination and field audits and participants agree to respond in a timely manner to requests for information and access to properties receiving water under the PSAWR.
- c) Failure to respond in a timely manner to information requests, associated data examination and field audits or recertification, or failure to provide reasonable access to properties receiving water under the PSAWR will result in automatic removal of the subject property from the PSAWR, subject to the conditions set for in subsection 10.11.5(c) of this Article, and subsequent water use on the property will be classified and billed as “Domestic” or “Commercial”.
- d) If, as a result of data examination and/or an audit, it is determined that PSAWR supply was used on property and/or for purposes not meeting the qualifications established by SDCWA, then said usage may be subject to assessment of retroactive supplemental water rates, penalties and charges as required by the SDCWA, or the District, which the participant agrees to pay.
- e) If data examination and/or an audit determines that the subject property and/or water use on the property does not qualify for the PSAWR, then the property and associated water account will be removed from the PSAWR as provided for and subject to the conditions in sub-section 10.11.5(c) of this Article, and subsequent water use on the property will be classified and billed as “Domestic” or “Commercial”.

Sec. 10.11.5 Exit and Re-entry into the PSAWR Program.

- a) PSAWR customers who knowingly no longer meet the participation qualifications of the PSAWR are required to inform the District within 30 days. Failure to provide notice of a change in eligibility within 30 days will result in retroactive assessment of the SDCWA M&I water rates and charges for the period of ineligibility in which the PSAWR water rate was received. .
- b) Customers electing to voluntarily exit the PSAWR will still be subject to PSAWR-related reductions if the customer exiting utilized PSAWR water in the base year for a mandatory reduction in a subsequent year. PSAWR customers may not voluntarily exit during periods of water shortage allocations and mandatory reductions for the duration the level is implemented or for three years, whichever is a shorter period, or during period in which there is substantial threat of a mandatory water supply reduction.
- c) Participating customers may opt-out of the PSAWR Program at any time during non-service limitation periods. If a PSAWR Program account has opted out, the parcel number associated with that retail meter account will not be allowed to re-enter the PSAWR Program unless the parcel legally changes ownership in an arm's length commercial transaction verified by the District..

Sec. 10.11.6 Implementation of Mandatory PSAWR Supply Reductions.

Actual implementation of mandatory supply reductions shall be based upon levels of reduction required the SDCWA. To achieve the required levels of use reduction and avoid the maximum penalty possible any operational or financial sanctions which may be imposed on the District by the SDCWA, the District will utilize one or a combination of methods, including timely notice of pending reductions, water management information dissemination, individual participant water budgets and use reduction targets, assessment of financial disincentives, and individual meter flow reduction devices.

Sec. 10.12 Installation or Extension Line Costs.

In connection with the installation or extension of water distribution lines, the District may concurrently install service lines for adjoining land parcels. The cost of the service lines together with the pipeline extension costs will be borne by the owners.

Where because of any unusual circumstance service connections involve extra expense to the District, an additional deposit or payment based upon the actual cost of such connection as determined by District staff, may be required by the District.

Sec. 10.13 Customer Valve.

There shall be a stopcock or wheel valve in every attachment between the meter and the main next to the meter which said stopcock or wheel valve and the meter and other devices and fittings, including the meter box supplied by the District, shall be for the exclusive use and under the control of the District.

There shall be a stopcock or wheel valve in each service connection located on the consumer's side of the meter, at a point to be designated by the District, which stopcock or

wheel valve shall be for the use of the consumer and shall be referred to as the “customer valve.”

The District has responsibility to repair or replace facilities up to and including the customer shut off valve. Repair and maintenance of facilities beyond the customer valve is the responsibility of the customer.

The District is not responsible for water loss due to leaks or other problems on the property side of the customer valve.

If there is an emergency, the District, at its discretion, can make temporary repairs and charge the customer a minimum of \$50. However, the District is under no obligation to repair leaks beyond the customer valve and assumes no long term liability for those repairs. It is recommended that the customer obtain the services of a licensed plumber to make permanent repairs.

Sec. 10.14                    Water Must Pass Through Meter.

All water sold by the District and used by any consumer must pass through that customer’s meter, and no delivery will be made by the District except through that customer’s meter. In the event that it should be discovered that water is served to any premises by means of a bypass or any other mechanical device or instrument which permits water to be served other than through that customer’s meter, the District shall have the right to immediately cut off the supply of water to said consumer until the person guilty of such conduct shall have reimbursed the District for the cost, as determined by the District, of the water so illegally used. The District shall assess a \$100 penalty, per incident, to any person who steals water in any amount.

Sec. 10.15                    Mains, Service Pipes, Equipment Belonging to District.

All water mains, extensions of service pipes, meters, and all other equipment used in the delivery of water to any meter, including the meter and the customer valve shall belong to and be the property of the District, and shall be maintained and repaired by the District.

Customer shall permit reasonable access to the meter and valves to effect said maintenance and repairs and to read the meter. Replacement shall be made by the District when such equipment is rendered unserviceable through reasonable use thereof.

However, the cost of replacements, repairs, or adjustments of any equipment of said District, including meters, when rendered necessary by any act, negligence or carelessness of the consumer, shall be made by the District at the expense of the consumer.

Sec. 10.16                    Meter Area Clean and Consumer Line Free from Leaks.

Every consumer of water must keep his service pipes, valves, fixtures, and all other apparatus beyond that belonging to and serviced by the District in good repair and free from leakage at his own expense and he will be responsible for all damages which may result from failure to comply with this rule.

Sec. 10.17                    Fires.

In the event that fires should take place within the District, where

it is necessary to use the distribution mains of the District to supply water to extinguish such fires, the District may temporarily discontinue service to any meter, and the affected consumer shall not be permitted to use water from any of the District mains until such fire is completely extinguished.

Sec. 10.18                    Access to Meters.

No person shall place or cause to be placed on or about or around any meter, hydrant, stopcock or service connection of any of the mains, pipes or water-works of the District any material of any kind which may serve or act as an obstruction to the free access or use of such meter, hydrant, stopcock or service connection. Upon failure to remove such obstruction after reasonable notice, the District shall have the right to have the water shut off and keep the same from being turned on again until such obstruction is removed and the necessary fee for turning on said water paid to the District.

Sec. 10.19                    Temporary Discontinuance of Service for Repairs, etc.

The District reserves the right at any time to discontinue the service of water from its mains to water consumers for the purpose of making repairs or extensions to all parts of the system under the operation and control of the District or for any other purpose which may be found necessary by the District in order to properly maintain its system. In such case, the District will, if practicable, give notice to the consumer of such interruption in service.

Sec. 10.20                    Allowances or Rebates.

No allowance or rebates in rates or charges shall be made under any circumstances, except as hereinafter in this Administrative Code authorized, and the rates herein prescribed for service of water shall be a charge against any and all property as hereinbefore specified, until the District shall receive written notice of request to discontinue the water to such property, provided, however, that notwithstanding such written notice or request, the District shall still collect the minimum amount prescribed by this Administrative Code for the standby service as long as the meter is in place.

Sec. 10.21                    Water Served to Others.

It is hereby declared to be a violation of the consumer's contract for which the District shall have the right to discontinue the service of water, if any water consumer shall be found to have served water to a consumer whose water has been shut off for breach of any of the provisions of this Administrative Code.

The District or representatives of the District shall have the right at all times to have free access to all parts of the premises of the consumer supplied with water to inspect the water system maintained by the customer.

Sec. 10.22                    Backflow Prevention Devices.

In accordance with Title 17 of the California Administrative Code, backflow prevention devices to protect the District distribution system from possible contamination will be owned and maintained by the District. The device will be located at the service connections. The type of protection that shall be required to prevent backflow into the public water supply shall be commensurate with the degree of hazard that exists on the customer premises. The type of protective device that will be required (listed in an

increasing level of protection) includes: Double check Valve Assembly-(DC), Reduced Pressure Principle Backflow Prevention Device-(RP) and an Air gap Separation-(AG). The customer may choose a higher level of protection than required by FPUD. The minimum types of backflow protection required to protect the public water supply, at the water user's meter connection to the property with various degrees of hazard, are listed below. Situations not covered in the listed below shall be evaluated on a case-by-case basis and the appropriate backflow protection shall be determined by FPUD.

Sec. 10.22.1 Type Of Backflow Protection Required.

1. An (AG) is required on premises where there are waste water pumping and/or treatment plants and there is no interconnection with the potable water system. This does not include a single-family residence that has a sewage lift pump. A RP may be provided in lieu of an AG if approved by the District.
2. An (AG) is required on premises where hazardous substances are handled in any manner in which the substances may enter the potable water system. This does not include a single-family residence that has a sewage lift pump. A RP may be provided in lieu of an AG if approved by the District.
3. An (RP) is required on premises where there are irrigation systems into which fertilizers, herbicides, or pesticides are, or can be, injected. Any sign of injection systems on the property, including unused systems will require an (RP).
4. Auxiliary Water Supplies--Any water supply other than that received from a public water system.
  - A) (AG) is required on premises where there is an unapproved auxiliary water supply which is interconnected with the public water system. A RP or DC may be provided in lieu of an AG if approved by the District.
  - B) An (RP) is required on premises where there is an unapproved auxiliary water supply and there are no interconnections with the public water system.
5. Recycled Water
  - A) An (AG) is required on premises where the public water system is used to supplement the recycled water supply.
  - B) An (RP) is required on premises where recycled water is used, and there is no interconnection with the potable water system.
  - C) An (RP) is required on residences using recycled water for landscape irrigation as part of an approved dual plumbed use area. If the District is also the supplier of the recycled water, to utilize an alternative backflow protection plan that includes an annual inspection and annual shutdown test of the recycled water and potable water systems.

## 6. Fire Protection Systems

- A) An (RP) is required on premises where the fire system is directly supplied from the public water system and there is an unapproved auxiliary water supply on or to the premises (not interconnected).
  - B) An (AG) is required on premises where the fire system is supplied from the public water system and interconnected with an unapproved auxiliary water supply. A RP may be provided in lieu of an AG if approved by the District.
  - C) An (RP) is required on Premises where the fire system is supplied from the public water system and where either elevated storage tanks or fire pumps which take suction from private reservoirs or tanks are used.
  - D) An (RP) is required on Premises where the fire system is supplied from the public water system and where recycled water is used in a separate piping system within the same building.
  - E) A (DC) is required for single family residence with fire protection system. The (DC) needs to be installed and maintained by the property owner.
- 7. An (RP) is required on premises where entry is restricted so that inspections for cross-connections cannot be made with sufficient frequency or at sufficiently short notice to assure that cross-connections do not exist.
  - 8. An (RP) is required on premises where there is a repeated history of cross-connections being established or re-established.
  - 9. An (RP) is required where adjacent parcels under common ownership are served by more than one meter. RP devices will be required at each meter.
  - 10. An (RP) is required on all new agricultural (AS), agricultural/domestic (AT), commercial agricultural (CA), or commercial agricultural domestic (CB) services. An RP will be installed by the District only with the new meter services.
  - 11. Property owners who appeal to the District to change classification from a classification other than agricultural (AS, AT, CA, CB) will be required to install a Reduced Pressure Backflow Preventer at the property owners expense. See Section 10.22.3 & 4.

Evaluation of Hazard. The District shall evaluate the degree of potential health hazard to the public water supply which may be created as a result of conditions existing on a user's premises. The District, however, shall not be responsible for abatement of cross-connections which may exist within a user's premises. As a minimum, the evaluation should consider: the existence of cross-connections, the nature of materials handled on the property, the probability of a backflow occurring, the degree of piping system complexity



and the potential for piping system modification. Special consideration shall be given to the premises of the following types of water users:

- A) Premises where substances harmful to health are handled under pressure in a manner which could permit their entry into the public water system. This includes chemical or biological process waters and water from public water supplies which have deteriorated in sanitary quality.
- B) Premises having an auxiliary water supply, unless the auxiliary supply is accepted as an additional source by the District.
- C) Premises that have internal cross-connections that are not abated to the satisfaction of the District.
- D) Premises where cross-connections are likely to occur and entry is restricted so that cross-connection inspections cannot be made with sufficient frequency or at sufficiently short notice to assure that cross-connections do not exist.
- E) Premises having a repeated history of cross-connections being established or reestablished.

Sec. 10.22.2 Backflow Device Installation on New Services.

The District shall install Reduced Pressure Backflow Preventers on new potable water meter services when applicable. (see Type of Backflow Device Protection Required)

An additional charge will be made for installation of backflow prevention devices as follows:

Reduced Pressure Principle Devices (installed along with new meter)

For each ¾ inch meter	\$475
For each 1 inch meter	\$560
For each 1-1/2 inch meter	\$1,034
For each 2 inch meter	\$1,251
For each 3, 4 or 6 inch meter	Cost

Backflow / RP device charges will be adjusted annually based on the ENR (Engineering News Record) Construction Cost Index (CCI) of February. Staff will report back to the Board of Directors no less than every five (5) years with analysis comparing fees to actual costs.

Sec. 10.22.3 Reduced Pressure Backflow Preventer Retrofits.

Retrofit: Installation of a Backflow device after the service connection has been established.

General Design Considerations.

- A) The design and construction of the backflow prevention assembly shall meet the requirements called for in this specification.
- B) The nominal size of the backflow prevention device shall be equal to the size of the purchased meter. For example, a (1") meter shall have a (1") backflow prevention device.
- C) The assembly shall include same size valves located on either side of the backflow prevention assemblies. Four test cocks shall be appropriately located on the assembly for testing and certification.
- D) The nominal size of reduced-pressure principle detector assemblies shall be as shown on the Approved Plans or as directed by the Fire Department of jurisdiction.
- E) Enclosures and concrete slabs shall be provided only as shown on the Approved Plans or as required by the agency of jurisdiction.

Sec. 10.22.4 Reduced Pressure Backflow Preventer Device Retrofit –Installed by Property Owner

The property owner shall be responsible for the Reduced Pressure Backflow Device Retrofit. Once the device is installed, passes the backflow test, and meets the District’s standards the device will become the property of the District. The device will be charged the standard monthly service charges and will be tested annually.

Upon notification by the District that a Reduced Pressure Backflow Device is needed, the property owner will have sixty (60) days to comply. After sixty (60) days, the District shall have the right to discontinue water service and charge a fee of fifty dollars (\$50) to lock the meter. A fee of one hundred (\$100) will be charged for broken or damaged locks. Damage to corp or angle stop in attempt to restore services will be billed at actual time and material and added to the water bill. The water service will be restored only after the fees are paid and the device is installed, passes, and meets the District standards.

Installation.

- 1) Installations of retrofit backflow devices will not be performed by District Personnel and is the sole responsibility of the property owner.
- 2) Forty-eight (48) hours prior to installation, the Backflow Department will be notified at (760) 728-1125, extension 1129. Installations and inspections will be scheduled Monday through Thursday’s only – excluding all District holidays. District personnel will shut off the angle stop before the meter. If the installer or property owner shuts off the angle stop and causes damage, the installer and property owner will be responsible for damages. The damages will be calculated at a time and materials rate.
- 3) Installation shall comply with the latest edition of the Uniform Plumbing Code and applicable District requirements.

- 4) Backflow prevention assemblies shall be installed in accordance with the District's standard drawings.
- 5) Water service and fire service shut-off valves will be secured closed during installation until an approved backflow prevention device is installed and tested in compliance with this specification.
- 6) When static pressure exceeds 175 psi, a pressure-reducing valve may be installed. Please contact the Backflow Department for determination of necessity.
- 7) After installation of the backflow device, the Backflow Department must be notified to inspect the installation to insure that the device meets the District specifications. It will then be tested by District personnel.
- 8) There will be no charge if the backflow device is installed correctly and test properly on the first inspection. If the backflow device fails the first test, it shall be the responsibility of the property owner to have any necessary repairs made. Repairs must be made according to District specifications. Any additional inspections will be charged one hundred twenty eight dollars (\$128) plus the costs of parts if needed.
- 9) Backflow / RP device charges will be adjusted annually based on the ENR (Engineering News Record) Construction Cost Index (CCI) of February. Staff will report back to the Board of Directors no less than every five (5) years with analysis comparing fees to actual costs.
- 10) Any damages or leaks after the customer shut-off valve will be the property owner's responsibility.

Sec. 10.22.5 Well Destruction and Alteration.

To protect the State's groundwater supplies, the Legislature authorized the establishment of standards (Department of Water Resources Bulletins 74-81 and 74-90) and regulations pertaining to the construction, alteration, and destruction of wells.

California Water Code Section 13750.5 requires that those responsible for the construction, alteration, or destruction of water wells, cathodic protection wells, groundwater monitoring wells, or geothermal heat exchange wells possess a C-57 Water Well Contractor's License. This license is issued by the Contractors State License Board.

California Water Code Section 13751 requires that anyone who constructs, alters, or destroys a water well, cathodic protection well, groundwater monitoring well, or geothermal heat exchange well file with the Department of Water Resources a report of completion within sixty (60) days of the completion of the work.

The Land and Water Quality Division regulates the design, construction, modification, and destruction of water wells throughout San Diego County to protect San Diego County's

groundwater resource. Water Wells are commonly used as the only potable water supply in the rural areas of San Diego County. For general information call the San Marcos office at (760) 471-0730.

Upon the completion of the well destruction or alteration, the property owner is responsible for supplying proper documentation to the District.

If the property owner chooses not to follow the California Water Code (listed above) within sixty (60) days, the District shall have the right to discontinue water service and charge a fee of fifty dollars (\$50) to lock the meter. A fee of one hundred (\$100) will be charged for broken or damaged locks. Damage to corp or angle stop in attempt to restore services will be billed at actual time and material and added to the water bill. The water service will be restored only after the fees are paid and a Reduced Pressure Backflow Device is installed (See Section 10.22.3&4) and passes and meets the District standards.

Sec. 10.23 Booster Pumps.

No person shall place or cause to be placed a device to raise the pressure of water supplied him by the District unless said booster system plans and proposals have been submitted to the District's General Manager and written approval for its installation and use has been secured. In the event such apparatus is installed without permission, the General Manager will immediately discontinue service to the consumer and resume service only after satisfactory removal or correction and payment of turn-on charges and payment for any repair or treatment necessary for sanitary and safe operation.

Sec. 10.23.1 Fallbrook Service Area Pressure Zones. Any approved individual service booster pump in the following pressure zones will be installed, operated, and maintained entirely at the individual customer's expense and will remain the property of the individual customer:

- 1) Toyon Heights
- 2) Sachse
- 3) Red Mountain
- 4) Gheen
- 5) Modified Town
- 6) Rattlesnake

Sec. 10.23.2 DeLuz Heights Service Area Pressure Zones. Any approved individual service booster pump in the DeLuz Service Area will be installed, operated, and maintained entirely at the individual customer's expense and will remain the property of the individual customer, with the exception of the following meter numbers:

- 1) Meter No. 7783
- 2) Meter No. 7784
- 3) Meter No. 7789

Sec. 10.24 Fire Hydrants.

For installing, maintaining and use of fire hydrants, the following will apply:

The District will install fire hydrants and necessary piping so required where and when jointly approved by the District staff and the Chief of the Fire District at the cost of the North County Fire Protection District.

In the event hydrants are required as part of pipeline extensions to service a subdivision or consumer, the cost of such hydrants will be included in the cost of the extension construction and paid for by the subdivider or consumer. Charges for installation of hydrants on the existing District distribution system will be as follows:

Model J-3700 (2-port hydrant).....	\$9,138	(complete assembly)
Model J-3765 (3-port hydrant).....	\$9,896	(complete assembly)
Fire flow testing .....	\$532	

If paving over 20 feet is required, there is an additional fee of \$257 per trench foot. If county road inspection is required, there is an additional fee of \$1,402.

Charges for fire hydrants will be adjusted annually based on the ENR (Engineering News Record) Construction Cost Index (CCI) of February. Staff will report back to the Board of Directors no less than every five (5) years with analysis comparing fees to actual costs. Maintenance and repairs to hydrants, valves and connecting pipelines, will be performed by the District at the expense of the North County Fire Protection District.

Sec. 10.25                    Automatic Sprinkler and Fire Protection Systems.

For automatic sprinkler and fire protection systems, the District upon request, will install a detector check valve system subject to the payment of the following installation charges by the user:

4 inch service .....	Cost
6 inch service .....	Cost
8 inch service .....	Cost

Sec. 10.26                    Construction Meters.

For each use of a fire hydrant by any person not officially associated with a fire fighting organization, by pre-arrangement and approval of the District, and upon receipt of a \$1,266 deposit, a meter installation charge of \$123 will be made. There will be a relocation charge of \$123 to cover cost of moving a construction meter. Upon notification by customer that the construction meter is no longer needed, District staff will retrieve the meter. Charges for construction meters will be adjusted annually based on the ENR (Engineering News Record) Construction Cost Index (CCI) of February. Staff will report back to the Board of Directors no less than every five (5) years with analysis comparing fees to actual costs. Upon retrieval, deposits will be refunded to the customer less any accrued operations charges and water use charges. The cost to repair a damaged construction meter will be deducted from the deposit. The construction meter will be locked to the fire hydrant and moved only by District staff. If the meter is stolen, the District will bear the cost of replacement.

Sec. 10.27                    Water Used for Annual Crops.

For each use of water for agricultural purposes solely for the growing of annual crops, as described in Sec. 10.1, Temporary Ag Service, the connection charge levied by Sec. 10.8 will not be assessed for this purpose.

All other fees, assessments, and charges of this Administrative Code will be in effect. The Board of Directors will determine annually the availability of water for these purposes, and the use will be continued on a year to year basis at the discretion of the Board of Directors.

Sec. 10.28                    Illegal Use of Water.

The District may discontinue service to any consumer who uses or permits the use of District water beyond District boundaries or who within the District permits the flow of water beyond the limits of his property which is recorded as being served by the meter service through which the water is supplied. After discontinuing service for such cause, a charge of \$100 plus the estimated cost of the water so wasted or misused will be made and water service will not be resumed until paid.

Sec. 10.29                    Water Service Outside District.

In the event that the District should at any time have surplus water over and above that which may be needed and used within the limits of the District, then and in that event, the Directors of the District are hereby authorized to enter into a contract for the sale of such surplus water outside the boundaries of the District, upon such terms and conditions and for such rates as the Directors may at the time deem for the best interests of said District, provided, however, that in no case shall the Directors of said District, in fixing the rate to be charged for water in such contract, charge less than a sum which would represent the cost of actually developing and delivering said water outside of said boundaries of said District.

Sec. 10.30                    Application of Water Service to Affordable Housing

Per Government Code Sec. 65589.7, effective July 1, 2006, the District shall not deny or condition the approval of an application for water service to, or reduce the amount of services applied for by, a proposed development that includes housing units affordable to lower income households unless the District makes specific written findings that the denial, condition, or reduction is necessary due to the existence of one or more of the following:

- a) The District does not have sufficient water supply as defined in paragraph (2) of subdivision (a) of Government Code Sec. 66473.7 or is operating under a water shortage emergency as defined in Water Code Sec. 350, or does not have sufficient water treatment or distribution capacity to serve the needs of the proposed affordable housing development as demonstrated by a written engineering analysis and report; or
- b) The District is subject to a compliance order issued by the State Department of Health Services that prohibits new water connections; or
- c) The District does not have sufficient sewer treatment or collection capacity to serve the needs of the proposed affordable housing development as demonstrated by a written engineering analysis and report; or
- d) The District is under an order issued by the Regional Water Quality Control Board that prohibits new sewer connections; or

- e) The applicant fails to agree to reasonable terms and conditions for water service from the District which is generally applicable to other development projects seeking water service from the District including, but not limited to, payment of any fee or charge authorized by Government Code §66013.

Sec. 10.30.1 Review of Service Policies.

At least once every five (5) years after passage of this policy, the policies contained in this section shall be presented to the Board of Directors of the District for a review and evaluation of the written policies governing water service to proposed developments that include housing units affordable to lower income households.

Sec. 10.31 Administrative Fees.

The following administrative fees will be charged for the preparation, processing, and recording of the following documents:

Insufficient Funds Check	\$25
Temporary Service Agreements	\$50
Remote Meter Agreements	\$50
Quitclaim of Easement	\$50
Grant of Easement	\$50
Grant Deed	\$50
Temporary Sewer Service Agreements	\$50
Repayment Agreements	\$100

<b>ARTICLE 19 (Renumbered as Article 10 by Resolution 5006)</b>
Sec. 19.1,19.4,19.6, 19.21, 19.23 & 19.28 – Rev. 6/93
Sec. 19.5, 19.21 & 19.24 – Rev. 2/94
Sec. 19.8 – Rev. 4/95
Sec. 19.1 – Rev. 8/95
Sec. 19.33-19.43 – Rev. 8/95
Sec. 19.5, 19.24-19.25 – Rev. 9/96
Sec. 19.6-19.8 – Rev. 9/96
Sec. 19.23 – Rev. 10/96
Sec. 19.8 – Rev. 6/97
Sec. 19.1 – Rev. 7/97
Sec. 19.11 – Rev. 7/98
Sec. 19.9 – Deleted (all parcels paid) – Rev. 9/98
Sec. 19.21 – Rev. 6/99
Sec. 19.8 – Rev. 7/99
Sec. 19.9 – Rev. 11/99
Sec. 19.20.2 – Rev. 11/99
Sec. 19.9.2 – Rev. 7/00
Sec. 19.8 – Rev. 12/00
Sec. 19.8 – Rev. 8/01

**ARTICLE 19 CONTINUED**  
**(Renumbered as Article 10 by**  
**Resolution 5006)**

Sec. 19.21, 19.23 – Rev. 07/03  
Sec. 19.6, 19.21 – Rev. 6/04  
Sec. 19.8, Rev. 1/05  
Sec. 19.5 – Rev. 7/05  
Sec. 19.4 & 19.8 – Rev. 3/06  
Sec. 19.5, 19.6, 19.19, & 19.21 – Rev.  
6/06  
New sec. 19.27 added 6/06  
Sec. 19.5, 19.8 & 19.23 – Rev. 12/06  
New Sec. 19.4 – Added 2//07  
Sec. 19.20 – Rev. 3/07  
Sec. 19.22 – Rev. 6/07  
Sec. 19.6 – Rev. 6/07; 19.7 – Added  
6/07; 19.20 – Rev. 6/07; 19.22 – Rev.  
6/07  
New 19.11 – added 8/07  
Sec. 19.1 (last para pg. 1) & 1<sup>st</sup> para. Pg.  
2 – Rev. 12/07  
Sec. 19.8.2 – Add 3/08  
Sec. 19.1, 19.6, 19.7, 19.8, 19.8.1, 19.9,  
19.14, 19.22, 19.24, 19.26, 19.27, and  
19.31 – Rev. 6/08  
Sec. 19.1, 19.6, 19.8, 19.8.2, 19.10,  
19.11.2, 19.11.3, 19.11.4, 19.11.5,  
19.11.6, 19.22,  
19.24, - Rev. 6/09  
19.1, 19.5 Rev. 8/09  
Sec. 19.22-19.22.5 – Rev. 10/09  
Sec. 19.8.1 – Rev. 5/10  
Sec. 19.5 – Rev. 10/10  
Sec. 19.3 – Rev 12/10  
Sec. 19.6, 19.7, 19.8.2, 19.22.2, 19.24,  
19.26 – Rev. 5/11  
Sec. 19.8, 19.9 – Rev. 4/12  
Sec. 19.1, 19.5, 19.6, 19.7, 19.8, 19.8.2,  
19.22.2, 19.24, 19.26 – Rev. 6/12  
Sec. 19.5, 19.6, 19.7, 19.8, 19.8.2,  
19.22.2, 19.24, 19.26 – Rev. 6/13  
Sec. 19.1, 19.5, 19.6, 19.7, 19.8, 19.8.2,  
19.10, 19.22.2, 19.24, 19.26 – Rev. 6/14  
Sec. 19.8.1 – Rev. 10/14  
Sec. 19.6, 19.7, 19.8, 19.8.2, 19.22.2,  
19.24, 19.26 Rev. 6/15  
Secs. 19.1, 19.5, 19.11, 19.11.1,  
19.11.2, 19.11.3,  
19.11.4, 19.11.5, 19.11.6, 19.22.1 Rev.  
3/16  
19.4.2 (add), 19.6, 19.7, 19.8, 19.8.2,  
19.10, 19.22.2, 19.24, 19.26 – Rev. 7/16  
Sec. 19.10 - Rev. 1/17



**ARTICLE 19 CONTINUED**  
**(Renumbered as Article 10 by**  
**Resolution 5006)**

Secs. 19.4.2, 19.6, 19.7, 19.8, 19.8.2,  
19.10, 19.22.2, 19.22.4, 19.24, 19.26 –  
Rev. 12/18

Secs. 19.12.1, 19.12.2, 19.24 – Rev.  
7/19

Secs. 19.4.2, 19.6, 19.7, 19.8, 19.8.2,  
19.10, 19.22.2, 19.24, 19.26 – Rev.  
12/19

Secs. 19.1, 19.5, 19.11, 19.11.1,  
19.11.2, 19.11.3, 19.11.4, 19.11.5,  
19.11.6 – Rev. 12/20

Secs. 19.4.2, 19.6, 19.7, 19.8, 19.8.2,  
19.10, 19.22.2, 19.22.4, 19.24, 19.26 –  
Rev. 12/20

**Article 11.                    Sewer Service Requirements and Fees**

**Sec 11.1                    Definitions.**

For the purpose of this Administrative Code and the regulation of sewer service by the Fallbrook Public Utility District, the following definitions are adopted:

The word “applicant,” as used herein, shall mean a person making application to the District for a permit for a sewer connection, Special Use Permit, determination or redetermination.

The term “application,” as used herein, shall mean the application form approved by the District for applicants to submit a request for sewer service to the District or for a Special Use Permit, or determination or redetermination of equivalent dwelling units.

The term “Authorized Inspector,” as used herein, shall mean the person designated by the General Manager to conduct inspections and take enforcement actions for the purpose of ensuring compliance with this chapter.

The term “Board,” as used herein, shall mean the governing board of the Fallbrook Public Utility District or any successor-in-interest.

The term “BOD,” as used herein, means biochemical oxygen demand.

The term “bypass” means the diversion of waste streams from any portion of the sewer system.

The term “discharge” means the addition of any material to the District’s sewer system.

The term “District,” as used herein, shall mean the Fallbrook Public Utility District or any successor-in-interest or any person authorized by the Board or General Manager to act as a representative of the District.

The term “Domestic Sewage” shall mean the liquid and water-borne wastes derived from humans in dwelling units and non-industrial commercial structures or uses, said wastes being of such character as to permit satisfactory disposal into a public sewer or private disposal system without special treatment.

The term “Equivalent Dwelling Unit” or “EDU,” as used herein, shall mean an increment of wastewater flow attributable to a single-family residence and as further discussed in Section 11.7.

The term “Industrial User” refers to a person whose discharges or processes have a different characteristic than domestic sewage or domestic activities and which may require special review or a Special Use Permit in accordance with this Article.

The term “Owner,” as used herein, shall mean the holder of record title to a parcel or parcels of real property located within the District.

The term “Parcel Map,” as used herein, shall mean the division of a parcel of land into four (4) or fewer lots in compliance with the Subdivision Map Act.

The term “Parcel of Land,” as used herein, shall mean a separate parcel of land recognized as a separate unit by the Assessor’s office for the County of San Diego and legally subdivided by California law.

The term “pass through” means wastewater leaving the District’s sewer system in quantities or concentrations which, alone or in conjunction with a discharge or discharges from other sources, is a cause of a violation of any requirement of the state or federal law, regulation, or order.

The term “Permit,” when used as a noun as used herein, shall mean permit for a sewer connection required by the District for any discharger to the District’s sewer system and includes a sewer permit, a Special Use Permit, a temporary sewer service agreement, and any other authorization to connect to and use the District’s sewer system.

The term “person,” as used herein, shall mean any individual, entity, partnership, firm, association, corporation or public agency, including the State of California and the United States of America.

The term “Project,” as used herein, shall mean the development, use, building or structure for which the owner is seeking sewer service and all developments, uses, buildings, and structures which have not previously secured a sewer permit from the District.

The term “sewer system” or “District’s sewer system” shall mean all of the publicly owned property involved in the operation of the sewage collection, treatment, and disposal system in the District, including land, sewers and appurtenances, pumping stations, and the treatment works and equipment.

The term “Special Use Permit” shall mean a permit for a sewer connection issued by the District to certain industrial users of the District’s sewer system in accordance with Section 11.9.

The Term “SS,” as used herein, means suspended solids.

The term “Subdivision,” as used herein, shall mean any improved or unimproved real property, or a portion thereof, shown on the latest equalized County Assessment Tax Roll as a unit or as contiguous units which is divided into five (5) or more parcels for the purpose of sale, lease or financing.

The term “upset” means an incident in which there is temporary noncompliance with requirements of the District’s sewer system regulations.

The term “user” refers to any person who connects to or discharges to or authorizes, permits, facilitates, or allows the connection or discharge to the District’s sewer system.

Sec 11.2 Prohibited Connections.

It shall be unlawful for any person to connect to or to facilitate, authorize, permit, or allow connection to the District sewer system or to add or to facilitate, authorize, permit, or allow the addition of any building, apartment, trailer, or other unit to an existing sewer connection or commence construction of any sewer line within the District without having first obtained a written permit from the District authorizing such connection or construction in accordance with Division 20.2 of this Article. No permit to connect shall be issued except to the owner of the property or the owner’s duly authorized agent.

Sec 11.3 Prohibited Uses and Prohibited Discharges.

It is unlawful for any person to use or discharge to, or to facilitate, authorize, permit, or allow the use of or discharge to, the sewer system except in accordance with Division 20.3.

Industrial users subject to the pretreatment standards specified in Part 403 of Title 40 of the Code of Federal Regulations are prohibited from connecting to or discharging into the District’s sewer system.

Sec 11.4 Permit Required.

No person or entity shall be entitled to establish, authorize, cause, facilitate or allow a connection or discharge to the District’s sewer system without first obtaining a sewer permit in accordance with Section 11.4, a Special Use Permit in accordance with Section 11.9 or a temporary sewer service agreement in accordance with Section 11.10 and paying required fees in accordance with this Article.

No person or entity shall be entitled to discharge or to authorize, cause, facilitate, or allow a discharge to the District’s sewer system except as authorized by a sewer permit, Special Use Permit or temporary sewer service agreement. Permits are issued only for the use expressly authorized by the permit.

If a permit does not show thereon the number of equivalent dwelling units for which it is issued, the holder of the permit may seek a determination of the equivalent dwelling units authorized by the permit in accordance with this Article.

The holder of a permit who seeks to undertake any of the following actions on the property associated with the permit must submit an application for a redetermination of equivalent dwelling units as set forth in Section 11.7 and/or a redetermination of strength classification under Section 11.8 and, if required apply for a new or amended permit and pay fees in accordance with this Article:

- a) add a new or change an existing use of a property;

- b) remodel, renovate, or enlarge a structure that discharges or connects to the District's sewer system;
- c) construct any additional improvements on the parcel of property that discharges or connects to the District's sewer system;
- d) discharge a greater volume of wastewater than is authorized by an existing sewer permit;
- e) discharge wastewater with a greater concentration of BOD, SS or other constituent than is authorized by the sewer permit.

No sewer permit required by this Section is valid until the applicant has paid all fees and charges of the District and complied with all requirements of this Administrative Code. An applicant does not have any right to sewer service until the permit is issued. Upon issuance of the permit, monthly service charges will commence in accordance with this Article.

Sec 11.5      Sewer Permit Application Process.

Sec 11.5.1    Submission of Application.

Any person required to obtain a permit in accordance with Section 11.4 must submit a request for sewer service from the District on the application form approved by the District. The application shall be made in the name of the Owner and be signed by the Owner or Owner's authorized representative. No application shall be deemed complete for the purposes of processing until the District has obtained all information requested by District staff to process the application, which may include but is not limited to the following:

- a) Environmental Review.

Upon request, the applicant shall provide the District with all documents evidencing any environmental review of the project for which the applicant seeks sewer service. If the District determines that additional environmental review is necessary, the applicant shall be required to complete this additional environmental review. All environmental review shall be at the applicant's sole cost and expense. The District may elect to utilize the applicant's environmental expert or may elect to retain its own environmental consultant at the applicant's sole cost and expense. Where District staff determines that the environmental review is insufficient, the District may require a deposit for additional environmental review as determined necessary by District staff. All costs for such additional environmental review shall be paid by the applicant.

- b) Plans and Specifications.

Except where waived by District staff, all applications for a sewer permit shall be accompanied by a complete set of all plans and specifications for the proposed development prepared by an architect or engineer licensed in the State of California. The District shall have no obligation to process any application until District staff has received

all plans and specifications determined necessary by District staff to consider the impacts of the proposed project on the District's sewer system.

c) Parcel Maps and Subdivisions.

Applications for sewer service to parcel maps and subdivisions will not be processed until the applicant submits an executed application form and the District has been provided with a copy of the parcel map or subdivision map prepared by a licensed civil engineer in the State of California. The parcel map or subdivision map shall show all proposed sewer facilities. Where the parcel map or subdivision will require a pipeline extension, the applicant will be required to execute a pipeline extension agreement.

Sec 11.5.2 Determination of Equivalent Dwelling Unit and Strength.

Upon receiving an application for issuance of a sewer permit, the District will determine the number of equivalent dwelling units and anticipated strength classification for which the Permit shall be issued, and fees shall be calculated in accordance with this Article.

Sec 11.5.3 Payment of Fees.

Before a sewer permit may be issued, the applicant must pay the following fees or arrange for payment of the fees pursuant to Section 11.16:

- a) Capacity fees in accordance with Section 11.16.2;
- b) Plan Check fees in accordance with Section 11.16.3;
- c) Lateral fees in accordance with section 11.16.4, if applicable;
- d) Fees to inspect contractor-installed laterals in accordance with Section 11.16.5, if applicable; and
- e) Annexation fee in accordance with Section 11.16.6, if applicable.

Sec 11.6. Sewer Availability Forms and Letters.

If an applicant has submitted a completed application, all environmental review has been completed to the satisfaction of the District, and the District has reviewed and approved the applicant's plans for sewer service, and all fees have been paid or guaranteed, the District may issue a sewer availability letter or execute the Sewer Project Facility Availability form provided by the County of San Diego.

Execution of the sewer availability letter or form is not a commitment that the District will provide sewer service to any project nor is it a guarantee that sewer service will be available to serve the project at the time a sewer commitment is actually made. Execution of the sewer availability letters or forms merely indicates that sewer service is available at the time the District executes the sewer availability letter or form. The District is not committed to provide sewer service until the District issues the permit, the applicant pays

all deposits and fees required by the District, and all sewer facilities required to serve the project by the District have been completed and accepted by the District.

Sec 11.7 Equivalent Dwelling Units.

a) Equivalent Dwelling Unit Schedules.

1. The following schedule shall be used when determining the equivalent dwelling units and class of service for any connection to the District’s sewer system.

(SEE SCHEDULE OF EQUIVALENT DWELLING UNITS AND CLASS OF SERVICE ON THE FOLLOWING PAGES)

SCHEDULE OF EQUIVALENT DWELLING UNITS AND CLASS OF SERVICE

Equivalent Class	Description	Dwelling Units
Class 1	Single Family Residence	
	Single family residence	1.00
	Mobile home on individual parcel	1.00
Class 2	Apartment/Condominium/Attached Cottage-Mobile Home	
	Per detached cottage with bathroom and kitchen on a parcel with a single family residence	0.80
	Per mobile home on a parcel with a single family residence	0.80
	Per apartment unit	0.80
	Per condominium/duplex unit	0.80
	Accessory Dwelling Unit* (As defined by State Government Code.)  *Capacity Fees do not apply to Accessory Dwelling Units (ADUs) that are exempt from such fees under State Law. Sewer Service Fees still apply, and they are determined by the applicable EDU factor.	0.40
Class 3	Mobile Home Park	
	Per separate mobile home space	0.80
	Motel/Hotel with no restaurant	
Class 4	Per motel/hotel with kitchen unit	0.80
Class 41	Per motel/hotel without kitchen unit	0.50
	A Separate Business, Retail Shop With Office, Or Packing House Equipped With Restroom Facilities, Or Not So Equipped But Located In A Building Or Complex With Common Restroom	
Class 5	First 3500 square feet (exterior building area) facilities	1.33

Class 55	Per additional 1000 square feet (exterior building area)	0.38
	Automotive Service Station	
Class 6	4 pumps or less	2.00
Class 61	More than 4 pumps	3.00
Class 62	Per recreational vehicle holding tank disposal station	1.00
	Church, Fraternal Lodge Or Similar Auditorium	
Class 7	Per 200 seating capacity	1.00
	Bakery	
Class 8	Per 3500 square feet (exterior building area)	1.00
	Theater	
Class 9	Per 150 seating capacity	1.33
	Hospital	
Class 10	Per bed	0.65
	Convalescent or Boarding Home	
Class 11	Per bed	0.30
	Elementary School / Daycare	
Class 13	Per 60 Students	1.00
	Junior High School	
	Per 40 Students	1.00
	High School	
Class 17	Per 30 Students	1.00
	Mortuary	
Class 14		1.00
	Car Wash with water recovery system and public restroom	
Class 21		2.00
	Self Service Laundry	
Class 23	Restaurants	2.00
	Restaurant Under 2500 Square feet	
Class 24		3.00
	Restaurant 2501-7000 Square feet	
Class 25		4.00
	Restaurant Over 7000 Square feet	
Class 26		5.00



	Grocery Stores	
Class 32	Grocery Stores Under 2500 feet	3.00
Class 33	Grocery Stores 2501-7000 Square feet	4.00
Class 34	Grocery Stores Over 7000 Square feet	5.00
Class 88	Standby	0.24

2. Unclassified Users. Users whose use is not classified in the above table are considered “unclassified users.” District staff shall determine the number of equivalent dwelling units for which a permit shall be issued to an unclassified user, including but not limited to commercial and industrial users, based upon the estimated volume of wastewater to be discharged therefrom into the District’s sewer system. An unclassified user that is also an Industrial User may be required to obtain a Special Use Permit pursuant to Section 2.9.

b) Determination and Redetermination of Equivalent Dwelling Units.

1. Determination of Equivalent Dwelling Units.

The holder of an existing sewer permit which does not show thereon the number of equivalent dwelling units for which it is issued, may make application to the District for a determination of equivalent dwelling units based on the current use of the property to which the permit relates.

Upon receipt of an application, the District shall determine the number of equivalent dwelling units which shall be credited to the permit based on this section.

Upon completing the determination of the number of equivalent dwelling units to be assigned to an existing permit, the District shall amend the permit to show thereon the number of equivalent dwelling units assigned thereto and shall also make a notation of such equivalent dwelling units assigned to the existing in the appropriate District record.

2. Redetermination of Equivalent Dwelling Units.

Upon receiving an application for a redetermination, the District shall determine the number of equivalent dwelling units assigned to such permit and the number of equivalent dwelling units required by the action undertaken by the permit holder. If the permit does not accurately show the number of equivalent dwelling units for which it was issued or which will exist after the action undertaken by the permit holder, the District shall determine the number of equivalent dwelling units to be assigned to such permit in the manner above provided in this section, and whether the action undertaken by the permit holder will necessitate additional equivalent dwelling units.

If additional equivalent dwelling units are required as a result of the action undertaken by the permit holder, the applicant will be required to acquire additional equivalent dwelling units in accordance with Section 11.4, to construct any additional sewer facilities determined necessary by the District to adequately serve the property, and to pay fees required by this Article based on the fees in effect at the time the application is submitted for the additional number of equivalent dwelling units calculated by District staff.

3. Reduction in Equivalent Dwelling Units.

If any determination or redetermination conducted in accordance with this Section results in a reduction in equivalent dwelling units, such reduction in capacity will reduce the ongoing capital improvement charge, but will not result in any refund of capacity fees.

Sec 11.8 Determination and Classification of Strength (BOD and SS).

The District shall use the following guidance when determining the anticipated concentrations of BOD and SS for discharges to the District's sewer system:

- a) Low strength: BOD < 200 mg/l and SS < 200 mg/l: Retail, laundry, church or community facility with no kitchen, offices, car wash, nursing home or hospital.
- b) Medium strength: BOD 200 - 700 or SS > 200 -700: hotel, auto service station, hotel with restaurant, light manufacturing.
- c) High strength: BOD > 700 mg/l or SS > 700 mg/l: Restaurant, mortuary, manufacturing or high strength wastes.

The allowable discharge strength classification shall be set forth in the permit.

Industrial Users required to obtain a Special Use Permit may be subject to alternative strength classification requirements and/or additional discharge requirements pursuant to Section 11.9.

Any user or applicant whose actual or proposed discharge is determined by the District to have characteristics that may adversely impact sewer system operations or the District's ability to comply with state and federal laws, regulations, or orders must immediately cease any actual discharge and obtain and implement a Special Use Permit in accordance with Section 11.9 before commencing or recommencing any such discharge.

Sec. 11.9 Special Use Permits.

Any user or applicant whose actual or proposed discharge is determined by the District to have characteristics that may adversely impact sewer system operations or the District's ability to comply with state and federal laws, regulations, or orders must immediately cease

any actual discharge and obtain and implement a Special Use Permit before commencing or recommencing any such discharge.

Applicants for Special Use Permits shall complete and file the standard application form and submit all applicable fees. Applications for a Special Use Permit shall include such additional information as may be required by the General Manager, which may include, but not be limited to, sewage constituents and characteristics (as may be determined by a laboratory approved by the District), and any other information deemed necessary by the District to evaluate the application.

The Special Use Permit shall be subject to all requirements and provisions applicable to general permits under this Article, but may also be subject to one or more of the following:

- a) Limitation of the volume discharged;
- b) Restriction of peak flow discharges;
- c) Pretreatment of wastewater prior to discharge;
- d) Discharge of certain wastewater only to specified sewers of the District;
- e) Relocation of the point of discharge;
- f) Prohibition or limitation of discharge of certain wastewater constituents;
- g) Restriction of discharge to certain hours of the day;
- h) Filing of periodic self-monitoring discharge reports or results of periodic measurements;
- i) Installation of a suitable manhole together with such necessary meters and other appurtenances to facilitate observation, sampling, and measurement of the wastes;
- j) Payment of additional charges to defray increased costs of the District created by the wastewater discharge; and
- k) Such other conditions as may be required to achieve the purpose of this section.

Sec 11.10 Temporary Sewer Service Agreement.

A Temporary Sewer Service Agreement is a recorded agreement between the District and a user that a sewer will be placed temporarily at a location remote from the property to be served, where the District intends, at some future date, to extend the District sewer system to abut the property described in the agreement, and that the consumer is responsible for extending a temporary private line from the sewer to the property to be served, and obtaining whatever temporary easements are required for such extension. Temporary sewer service agreements shall establish the financial obligations of the user related to the

future installation costs of the District's distribution system and the cost of relocation of the sewer, and shall be binding upon the signatory and all successor owners of said property.

If the user's obligation is to be secured with a promissory note and deed of trust, the terms will be based on the 10-year Treasury Bill rate plus 2%. Interest will be recalculated annually on the anniversary date of the recorded Trust Deed and will be compounded annually on the same anniversary date.

Sec. 11.11 Permit Modifications.

The terms and conditions of a permit may be subject to modification by the District, in accordance with any changes in the effluent standards limitations or prohibited substances by superior regulators or in response to violations of this Code. The discharger shall be informed of any proposed changes in the permit at least thirty (30) days prior to the effective date of change, except in the case of violations of a permit or other order of the District, which may be modified as needed to protect public health, safety, and welfare, the District's sewer system, or personnel. Any modifications or new conditions in the permit shall include a reasonable time schedule for compliance.

No person shall discharge sewage in excess of the quantity or quality limitations set by a permit. Anyone desiring to discharge wastes or use wastewater facilities that are not in conformance with terms of a permit must apply to the District for an amendment to the permit or for a Special Use Permit, as applicable.

Sec. 11.12 Permits Non-Transferable.

A permit issued for a particular parcel of land is specifically limited to use for that parcel of land. A permit shall not be transferred to or used for a parcel of land which is not specifically described in the permit. Permits may be used only for the use which is specifically set forth on the permit.

Sec 11.13 Application of Sewer Service to Affordable Housing.

Per Government Code Sec. 65589.7, effective July 1, 2006, the District shall not deny or condition the approval of an application for sewer service to, or reduce the amount of services applied for by, a proposed development that includes housing units affordable to lower income households unless the District makes specific written findings that the denial, condition, or reduction is necessary due to the existence of one or more of the following:

- a) The District does not have sufficient water supply as defined in paragraph (2) of subdivision (a) of Government Code Sec. 66473.7 or is operating under a water shortage emergency as defined in Water Code Sec. 350, or does not have sufficient water treatment or distribution capacity to serve the needs of the proposed affordable housing development as demonstrated by a written engineering analysis and report; or

- b) The District is subject to a compliance order issued by the State Water Resources Control Board, Division of Drinking Water that prohibits new water connections; or
- c) The District does not have sufficient sewer treatment or collection capacity to serve the needs of the proposed affordable housing development as demonstrated by a written engineering analysis and report; or
- d) The District is under an order issued by the Regional Water Quality Control Board that prohibits new sewer connections; or
- e) The applicant fails to agree to reasonable terms and conditions for sewer service from the District which is generally applicable to other development projects seeking sewer service from the District including, but not limited to, payment of any fee or charge authorized by Government Code §66013.

Sec. 11.14 Sewer Use Requirements.

Sec. 11.14.1 General Conditions for Sewage Disposal.

No person shall discharge to the District's sewer system except through a connection permitted in accordance with Division 20.2 and in accordance with the sewer use requirements of this Division 20.3 and on payment of fees and charges provided in Division 20.4. Unless specifically authorized in a Special Use Permit issued by the District, no person shall discharge to the District's sewer system anything other than domestic sewage that complies with the requirements of this Article.

No person shall discharge to the District' sewer collection system in any manner that does the following:

- a) Create nuisances such as odors,
- b) Menace or endanger public health or safety or damage public or private structures, facilities or improvements,
- c) Impose unreasonable collection, treatment, or disposal costs to the District,
- d) Interfere with wastewater treatment processes,
- e) Exceed quality requirements set by regulatory government agencies,
- f) Detrimentially affect the local environment,
- g) Causes or contributes or threatens to cause or contribute to a bypass of untreated waste, pass through, or upset; or
- h) Cause or contribute to a violation of any permits applicable to the District's sewer system or treatment facilities.

Sec. 11.14.2 Discharge Prohibition.

Unless written approval has been provided by the District, no person shall discharge or cause to be discharged into the District's sewer, directly or indirectly, the following:

- a) Any storm water, surface water, groundwater, roof runoff, subsurface drainage, uncontaminated cooling water, or industrial process waters.
- b) Pollutants which create a fire or explosion hazard, including but not limited to any gasoline, benzene, naphtha, fuel oil, or other flammable or explosive liquid, solid, or gas.
- c) Any waters or wastes containing toxic or poisonous solids, liquids, or gases in sufficient quantity, either singly or by interaction with other wastes, to injure or interfere with any sewage treatment process, constitute a hazard to humans or animals, create a public nuisance, or create any hazard in the receiving waters of the sewage treatment plant, including but not limited to cyanides in excess of two (2) mg/L as CN in the wastes as discharged to the public sewer.
- d) Pollutants which will cause corrosive structural damage to the sewer system, but in no case any waters or wastes having a pH lower than 6.0 or in excess of 9.0, or having any other corrosive property capable of causing damage or hazard to structures, equipment, and personnel of the sewage works.
- e) Solid or viscous substances in quantities or of such size capable of causing obstruction to the flow in sewers, or other interference with the proper operation of the sewage works such as, but not limited to, cinders, sand, mud, straw, shavings, metal, glass, rags, feathers, tar, plastics, wood, ashes, unground garbage, whole blood, paunch manure, hair and fleshings, entrails and paper dishes, cups, milk containers, etc., either whole or ground by garbage grinders.
- f) Any pollutant, including oxygen demanding pollutants (BOD, etc.) released in a discharge at a flow rate and/or pollutant concentration which will cause interference with the sewer system.
- g) Brine from on-site regenerated ion exchange water treating devices.
- h) Water softener waste or any other salt water brine wastes.
- i) Any trucked or hauled pollutants, except at discharge points designated by the District.
- j) Fats, oils and grease (FOG) from food service establishments, except in compliance with the District's FOG program.
- k) Any other substances, materials, waters, or wastes if it appears likely in the opinion of the District's General Manager that such wastes can harm either the sewers, sewage treatment process, or equipment, have an adverse effect on the receiving

stream, or can otherwise endanger life, limb, public property, or constitute a nuisance. In making a determination as to the acceptability of these wastes, the General Manager will give consideration to such factors as the quantities of subject wastes in relation to flows and velocities in the sewers, materials of construction of the sewers, nature of the sewage treatment process, capacity of the sewage treatment plant, degree of treatability of wastes in the sewage treatment plant, and other pertinent factors. The substances prohibited are:

- l) Heat in amounts which will inhibit biological activity in the sewer system resulting in interference, but in no case any liquid or vapor having a temperature higher than one hundred fifty (150) °F (65°C).
- m) Any water or waste containing fats, wax, grease, or oils, whether emulsified or not, in excess of two hundred (200) mg/L or containing substances which may solidify or become viscous at temperatures between thirty two (32) and one hundred fifty (150) °F (0 and 65° C).
- n) Any garbage that has not been properly shredded. The installation and operation of any garbage grinder equipped with a motor of three fourths (3/4) horsepower (0.76 hp metric) or greater shall be subject to the review and approval of the District.
- o) Any waters or wastes containing strong acid iron picking wastes, or concentrated plating solutions whether neutralized or not.
- p) Any water or wastes containing boron, cadmium, chromium, copper, iron, lead, manganese, mercury, selenium, tin, zinc and similar objectionable or toxic substances, or wastes exerting an excessive chlorine requirement, to such degree that any such material received in the composite sewage at the sewage treatment works exceeds the limits established by the District for such materials. And, any water or wastes containing constituents in excess of those required by the District's current permits.
- q) Any water or wastes containing phenols or other taste odor producing substances, in such concentrations exceeding limits which may be established by the District as necessary, after treatment of the composite sewage, to meet the requirements of the State, Federal, or other public agencies of jurisdiction for such discharge to the receiving waters.
- r) Any radioactive wastes or isotopes of such half-life or concentration as may exceed limits established by the District in compliance with applicable State or Federal regulations.
- s) Materials which exert or cause:
  1. Any waters or wastes containing more than 350 parts per million by weight of suspended solids or have a 5 day B.O.D. greater than 300

parts per million by weight, or a C.O.D. greater than 600 parts per million by weight.

2. Excessive discoloration (such as, but not limited to, dye wastes and vegetable tanning solutions).
  3. Unusual B.O.D. chemical oxygen demand, or chlorine requirements in such quantities as to constitute a significant load on the sewage treatment works.
  4. Unusual volume of flow or concentration of wastes constituting “slugs” as defined herein.
- t) Waters or wastes containing substances which are not amenable to treatment or reduction by the sewage treatment processes employed, or are amenable to treatment only to such degree that the sewage treatment plant effluent cannot meet the requirements of other agencies having jurisdiction over discharge to the receiving waters.

Sec. 11.14.3 FOG Compliance Program.

The District has prepared and adopted a fats, oils, and grease (FOG) program on the implementation and enforcement of this Article. The District may require compliance with the FOG program as a condition of a Special Use Permit under this Article. FOG program may be updated as needed to achieve the applicable performance standards for the sewer system.

Sec. 11.15 Miscellaneous Provisions.

Sec. 11.15.1 Provide Information.

Users must provide information regarding the nature of any discharge to the system on request of the District.

Sec. 11.15.2 Users Outside the District.

The Board of Directors of the District shall have the power under Sec. 16474 of the Public Utilities Code to establish by agreement or resolution, the fees and charges and such other conditions as it deems appropriate that shall be imposed for providing sewer services to premises located outside the District. The provision of sewer services to premises outside the District shall also comply with applicable law, including but not limited to the Cortese-Knox-Hertzberg Local Government Reorganization Act of 2000 (Gov. Code § 56000 et seq.).

Sec. 11.15.3 Agreements.

No statement contained in this Article shall be construed as preventing any special agreement or arrangement between the District and any discharger whereby waste



of unusual strength or character may be accepted by the District for treatment, subject to payment as agreed thereof by the discharger.

Sec. 11.16 Fees and Charges.

Sec. 11.16.1 Sewer Service Charges.

Every user of the District's sewer system must pay a sewer service charge for the use of the District's sewer system in an amount and at a frequency established by the Board.

Sec. 11.16.2 Capacity Fees.

a) Capacity Fee Amount. Prior to issuance, reissuance, or amendment of a sewer permit the following capacity fees shall be paid by an applicant for a sewer permit for each equivalent dwelling unit determined by the District in accordance with Section 11.7:

Capacity Fee	\$7,115 per EDU
--------------	-----------------

b) Adjustments to Capacity Fees. Capacity fee charges will be adjusted annually based on the ENR (Engineering News Record) Construction Cost Index (CCI) of February. Staff will report back to the Board of Directors no less than every five (5) years with analysis comparing fees to actual costs.

c) Financing Capacity Fees. Finance options are available for customers who owe additional fees to the District due to property expansions that did not purchase additional capacity and/or visual audits conducted by District staff as follows:

1. Any amounts financed by the District require a signed agreement and Promissory Note. Any amount greater than \$10,000 will also require a Trust Deed.
2. Any delinquent amounts will be transferred to the property tax bill.
3. Amounts up to \$3,000 are due immediately with no financing option.
4. Amounts between \$3,001 and \$5,000 may have terms of up to one year at the Local Agency Investment Fund (LAIF) rate + 2%.
5. Amounts between \$5,001 and \$10,000 may have terms of up to two years at the LAIF rate + 3%; interest to be re-calculated at the one year anniversary.
6. Amounts greater than \$10,001 may have terms up to three years at the LAIF rate + 4%; interest to be re-calculated at the one year and two year anniversaries.
7. Liens will not be offered as a methods of postponing payment of fees.

Sec. 11.16.2 Plan Check Fees.

- a) An applicant must pay a plan check fee in accordance with the following:
1. Plan checks less than 500 lineal feet, water or sewer, \$500 each.
  2. Plan checks 500 lineal feet to 1,000 lineal feet, water or sewer, \$1,000 each.
  3. Plan checks greater than 1,000 lineal feet, \$1,000 each, plus .50 cents per lineal foot thereafter.

Sec. 11.16.4 Lateral Fees.

If the District staff will be utilized to install a lateral from the main line and to put in a clean-out box and overflow device, the applicant shall pay the following fee upon submission of an application. The fee is to cover the cost to install a lateral from the main line and to install the clean-out box and overflow device, if a lateral is required based on the nature of the application:

Length	Depth	Crew Size	Hours	Cost
≤ 15'	≤ 8'	4	36	\$3,500
≤ 15'	>8'	4	56	\$5,422
>15' to 30'	≤8'	5	90	\$7,443
>15' to 30'	>8'	5	115	\$9,586
>30'	Any	5	Actual	Actual

If paving less than or equal to 15 feet is required, there is an additional fee of \$1,470. If paving is greater than 15 feet up to 30 feet is required, there is an additional fee of \$2,462. If county road inspection is required, there is an additional fee of \$1,402.

Lateral installation charges will be adjusted annually based on the ENR (Engineering News Record) Construction Cost Index (CCI) of February. Staff will report back to the Board of Directors no less than every five (5) years with analysis comparing fees to actual costs.

Sec 11.16.5 Fees for District to Inspect Contractor-Installed Facilities.

If a contractor will install the sewer lateral and related facilities, the applicant shall pay a sewer lateral inspection fee on a time and materials basis. Upon submission of an application, the applicant shall pay a deposit for the estimated inspection fee, calculated as follows:

Sewer Lateral Installation      Estimated inspection hours @ \$106.31 = Estimated inspection fee

If the actual time per form inspection is less than the District's estimate, the District will refund the excess amount to the applicant. If the actual time to perform inspection exceeds the estimated time, the applicant shall pay the remaining amount due to the District as a condition of service. If the applicant fails to pay within the time specified by the District,

the District may include the remaining amount in its bill for for sewer service or seek collection through any other lawful means.

Inspection fees will be adjusted annually based on the Engineering News Record (ENR) Construction Cost Index (CCI) of February. Staff will report back to the Board no less than every five (5) years with analysis comparing current fees to calculated fees.

Sec. 11.16.6 Annexation Fees.

An applicant must pay a sewer annexation fee for any connection located in an area that is required to be annexed to the sewer service area after March 23, 2012 in accordance with state law. Annexation fees are due with the other sewer permit fees when applying for a sewer permit and are calculated for each equivalent dwelling unit determined by the District in accordance with Section 11.7.

Annexation Fee (if required)	\$11,389 per EDU
------------------------------	------------------

Sec. 11.16.7 Fees and Charges May Be Collected with Taxes.

Notwithstanding any other provision of this Administrative Code, the fees and charges required by this Code, including the connection fee and the sewer service charges, or either of them may be collected on the tax roll in the same manner and together with the general taxes of the District pursuant to Section 16469 of the Public Utilities Code.

Sec. 11.17 Right of Entry and Inspection.

To the fullest extent permitted by law, the officers, employees, and agents of the District shall have the right to enter upon any premises within the District to inspect and verify compliance with the Administrative Code or any permit, order, ordinance or authorization issued by the District. The District has the right to conduct routine inspections and sampling at any location where discharges to the sewer system occur.

Sec. 11.18 Enforcement – Generally.

In addition to any remedies provided in this Code or available under any applicable law, the District may take any enforcement action or combination of enforcement actions provided in this Division against any person who violates any provision of this Article.

Sec. 11.19 Administrative Enforcement.

Sec. 11.19.1 Monitoring.

The Authorized Inspector may require any discharger who violates any provision of this Article or any permit, agreement, or other authorization issued in accordance with this Article to pay all costs associated with follow-up sampling, cost of analysis, and inspections needed to return the discharger to compliance. The discharger may be required

to install and maintain pre-treatment, monitoring, and sampling facilities to ensure compliance with this Code.

Sec. 11.19.2 Citations.

The Authorized Inspector may issue an administrative citation directing a user or discharger to cease any action that violates any provision of this Article or any permit, agreement, or other authorization issued in accordance with this Article and may require the user or discharger to take any action necessary on a reasonable timeline to return to compliance and to pay penalties and costs authorized by law or this Article.

Sec. 11.19.3 Termination of Service and Revocation of Permit.

In addition to other statutes or rules authorizing termination of service for delinquency in payment for sewer service, the District may revoke any permit issued pursuant to these regulations. The District may also terminate the sewer or water service to any property, if a violation of any provision of this Article or a permit is found to exist, or if any wastewater discharge into the District's sewer system causes or threatens to cause a condition of contamination, pollution, or nuisance.

When deemed necessary for the preservation of public health or safety, or for the protection of public or private property, the District may suspend or terminate sewer or water service to any person using the sewer system in a manner endangering the public health or safety, or public or private property. If such endangerment shall be imminent, the District may act immediately to suspend sewer service without notice or warning to said discharger. In terminating service, the District may sever all pertinent connections to the public sewer.

Sec. 11.19.4 Permit Amendment.

In the event that the user demonstrates non-compliance or potential non-compliance with the limitations set forth in this Article or in any permit, agreement, or other authorization issued in accordance with this Article, the District may require the user to obtain a Special Use Permit or may modify an existing permit.

Sec. 11.19.5 Cost Recovery.

A person violating this Code or a permit or agreement or other authorization issued in accordance with this Article, or who discharges wastewater that causes a deposit, obstruction, damage, or any other impairment to the District's sewer system shall become liable for all expense, loss, or damage sustained by the District by reason of such violation or discharge. Such expenses, losses and damages include the District's costs of investigation and of taking any enforcement action required to return the user to compliance.

In addition to such costs, the District may recover reasonable attorneys' fees, court costs, court reporters' fees and other expenses of litigation by means of an appropriate lawsuit or

other remedy against the person or discharger found to have violated these regulations or any discharge permit issued.

The District may condition the provision or continued provision of service on the payment of such expenses, losses, and damages.

Sec. 11.19.6 Administrative Complaint – Pretreatment Violations.

- a) In accordance with Section 54740.5 of the Government Code, the Authorized Inspector may issue an administrative complaint to any person who violates any requirement adopted or ordered by a local agency pursuant to Section 11.9. The administrative complaint shall allege the act or failure to act that constitutes the violation of the requirements, this Section, and the proposed civil penalty.
- b) The administrative complaint shall be served by personal delivery or certified mail on the person subject to the discharge requirements, and shall inform the person served that a hearing shall be conducted within 60 days after the person has been served. The hearing shall be before a hearing officer designated by the General Manager. The person who has been issued an administrative complaint may waive the right to a hearing, in which case no hearing will be conducted. A person dissatisfied with the decision of the hearing officer may appeal to the Board within 30 days after notice of the hearing officer's decision.
- c) If after the hearing, or appeal, if any, it is found that the person has violated reporting or discharge requirements, the hearing officer or Board may assess a civil penalty against that person. In determining the amount of the civil penalty, the hearing officer or Board may take into consideration all relevant circumstances, including, but not limited to, the extent of harm caused by the violation, the economic benefit derived through any noncompliance, the nature and persistence of the violation, the length of time over which the violation occurs and corrective action, if any, attempted or taken by the discharger.
- d) Civil penalties may be imposed as follows:
  1. In an amount which shall not exceed two thousand dollars (\$2,000) for each day for failing or refusing to furnish technical or monitoring reports.
  2. In an amount which shall not exceed three thousand dollars (\$3,000) for each day for failing or refusing to timely comply with any compliance schedule established by the Authorized Inspector.
  3. In an amount which shall not exceed five thousand dollars (\$5,000) per violation for each day for discharges in violation of any waste discharge limitation, permit condition, or requirement issued, reissued, or adopted by the District.

4. In an amount which does not exceed ten dollars (\$10) per gallon for discharges in violation of any suspension, cease and desist order or other orders, or prohibition issued, reissued, or adopted by the District.
  5. The amount of any civil penalties imposed under this section which has remained delinquent for a period of 60 days shall constitute a lien against the real property of the discharger from which the discharge originated resulting in the imposition of the civil penalty. The lien provided herein shall have no force and effect until recorded with the county recorder and when recorded shall have the force and effect and priority of a judgment lien and continue for 10 years from the time of recording unless sooner released, and shall be renewable in accordance with the provisions of Sections 683.110 to 683.220, inclusive, of the Code of Civil Procedure.
- e) All moneys collected under this section shall be deposited in a special account of the District and shall be made available for the monitoring, treatment, and control of discharges into the District's sewer system or for other mitigation measures.
  - f) Unless appealed, orders setting administrative civil penalties become effective and final upon issuance thereof, and payment shall be made within 30 days. Copies of these orders shall be served by personal service or by registered mail upon the party served with the administrative complaint and upon other persons who appeared at the hearing and requested a copy.
  - g) The local agency may, at its option, elect to petition the superior court to confirm any order establishing civil penalties and enter judgment in conformity therewith in accordance with the provisions of Sections 1285 to 1287.6, inclusive, of the Code of Civil Procedure.
  - h) No penalties shall be recoverable under this section for any violation for which civil liability is recovered under Section 54740 of the Government Code.

Sec. 11.20 Public Nuisance.

- a) Discharge of wastewater in any manner that is in violation of this Article or a permit, or any order issued by the District as authorized herein, is hereby declared a public nuisance and shall be corrected or abated as directed by the District. Any person creating such a public nuisance is guilty of a misdemeanor and may be referred for criminal prosecution.
- b) If any wastes or waters are discharged, or are proposed to be discharged to the public sewers, which waters contain the substances or possess the characteristics prohibited under this Article, and which in the judgement of the District, may have a deleterious effect upon the sewage works, processes, equipment, or receiving waters, or which otherwise create a hazard to life or constitute a public nuisance, the District may:
  1. Reject the wastes,

2. Require pretreatment to an acceptable condition for discharge to the public sewers,
3. Require control over the quantities and rates of discharge,
4. Require discharger to obtain and comply with an Special Use Permit under this Article,
5. Require payment to cover the added cost of handling and treating the wastes not covered by the sewer charges levied by the District, and/or
6. Take any or all enforcement actions available to the District for violations of this Article.

Sec. 11.21 Civil Enforcement.

Sec. 11.21.1 Injunction.

Whenever a discharge of wastewater or other action is found to be in violation of this Code or a permit, or otherwise causes or threatens to cause a condition of contamination, pollution, or nuisance, the District may petition the Superior Court for the issuance of a temporary restraining order, preliminary injunction, permanent injunction, or all, as may be appropriate to restrain such action or require compliant actions.

Sec. 11.21.2 Other Actions.

The District may take any other civil action available at law or in equity to enforce the provisions of this Code.

Sec. 11.21.3 Criminal Enforcement.

Violations of this Code may constitute violations of other federal, state, or local laws. The District may refer such violations to the appropriate law enforcement agency for prosecution.

Sec. 11.22 Appeal Process.

Sec. 11.22.1 Appeals of Determinations and Redeterminations of EDUs.

- a) The owner of a property subject to a determination or redetermination made in accordance with Section 11.7 may appeal that determination or redetermination to the General Manager within fifteen (15) days after the District delivers notice of the determination or redetermination in accordance with Section 11.23 by submitting a written appeal and supporting documentation.
- b) The appellant may submit evidence and the hearing officer shall only consider evidence that is relevant to whether the determination or redetermination was made in error and whether an alternative determination or redetermination is justified,

such as evidence that discharges will be lower than the typical industry values identified in the schedule or otherwise determined by the District.

- c) The hearing officer will grant the appeal in whole or in part if it determines that the evidence submitted by the appellant justifies an alternative determination.

#### Sec. 11.22.2 Appeals of Special Use Permit Requirements.

- a) Any person subject to a Special Use Permit issued in accordance with Section 11.9 may appeal any term or condition included in the Special Use Permit to the General Manager within fifteen (15) days after the Special Use Permit is delivered in accordance with Section 11.23 by submitting a written appeal and supporting documentation.
- b) The appellant may submit evidence and the hearing officer shall only consider evidence regarding (a) the discharger's ability to meet the District's effluent standards; (b) the requested variance and its impacts on the operation of any District wastewater treatment plant or improvements.
- c) The hearing officer will grant the appeal in whole or in part if the following criteria can be demonstrated: (a) that the discharger is unable to meet the District's effluent standards by means of reasonable modifications to the discharging facility; (b) that the requested variance will not directly impact the operation of any District wastewater treatment plant or improvements, cause the wastewater or sludge of such plant to violate applicable requirements, or harm facilities or personnel; and (c) that the easing of any effluent standards will not violate any State or Federal requirements applicable to the District.

#### Sec. 11.22.3 Appeals of Administrative Enforcement Actions.

- a) Any person subject to an administrative enforcement action appeal from the issuance thereof to the General Manager within fifteen (15) days of the date of delivery of the administrative enforcement action by the Authorized Inspector. A person subject to an order to remedy a condition which poses an immediate threat to the public health, safety or welfare shall comply with that order during the pendency of any appeal.
- b) The only issues on appeal may be whether there was a violation as alleged in the administrative enforcement action and whether the appellant is the person responsible for the violation or corrective action.
- c) The amount of any fine or penalty imposed with the administrative enforcement action must be submitted together with the written appeal. Any fine which has been deposited shall be refunded if it is determined, after a hearing, that the person subject to the administrative enforcement action was not responsible for the violation or that there was no violation as alleged in the administrative enforcement action.



Sec. 11.22.4 Hearing on Appeal.

- a) Whenever a hearing is required or held in accordance with this Article, the General Manager or hearing officer appointed by the General Manager shall endeavor to set a date for the hearing that is not less than fifteen (15) and not more than sixty (60) days after the date that the written appeal is filed.
- b) The District shall notify person requesting the hearing of the time and place set for the hearing at least ten (10) days prior to the date of the hearing.
- c) The failure of any person requesting a hearing to appear at the hearing shall constitute a forfeiture of the appeal and any fine, and shall be a bar to judicial review of the action based upon a failure to exhaust administrative remedies.
- d) The hearing officer shall only consider evidence that is relevant to the issues identified in this Section.
- e) The appellant shall be given the opportunity to testify and present witnesses and evidence concerning the administrative citation.
- f) The District's determination or redetermination, permit or agreement, or administrative enforcement action and any additional document created by the District shall constitute prima facie evidence of the respective facts contained in those documents. Formal rules of evidence shall not apply.
- g) Upon request, the person requesting a hearing shall be provided with copies of the citations, reports and other documents submitted or relied upon by the District when taking the action subject to the appeal. In addition, if the District submits any additional written reports concerning action subject to the hearing to the hearing officer for consideration at the hearing, then a copy of said documentation also shall be served by mail on the person requesting the hearing.
- h) The hearing officer may continue the hearing and request additional information from the District or the person requesting the hearing prior to issuing a written decision.
- i) After considering all of the testimony and evidence submitted at the hearing, the hearing officer may immediately issue a verbal decision or may issue a written decision within ten (10) days of the hearing. The decision shall include the reasons for the decision and such decision shall be final. If the hearing officer determines that the administrative citation should be upheld, then the fine amount on deposit with the city shall be retained by the city. If the hearing officer determines that an administrative citation should be canceled and the fine was deposited with the city, then the city shall promptly refund the amount of the deposited fine.
- j) If any action is not timely appealed as provided in this Article, the action becomes final.

Sec. 11.22.5 Appeal to Board.

The decision of a hearing officer issued in accordance with this Article may be appealed to the Board within fifteen (15) days after delivery of the notice of such decision in accordance with Section 11.23. An appeal under this Section must be submitted to the General Manager on a form or in a format specified by the District. The only issue on appeal shall be whether the decision of the hearing officer is supported by the evidence.

Sec 11.22.6 Judicial Review.

Any person subject to a decision of the Board on an appeal of a decision of a hearing officer may obtain review of the decision of the Board by filing a petition with the Superior Court of San Diego in accordance with the timelines and provisions applicable to writs of mandate under Code of Civil Procedure section 1094.5.

Sec 11.23 Delivery of Notice.

Notice of any administrative enforcement action or other action of the District required be delivered pursuant to the requirements of this Article shall be subject to the following:

- a) Notice of any administrative enforcement action shall state that the recipient has a right to appeal the matter as set forth in Section 11.22 of this Article.
- b) Notice shall be delivered by personal service to the recipient, deposit in the U.S. mail, postage prepaid for first class delivery, by facsimile service with confirmation of receipt, by posting on the property, or by any other means permitted by law, including by electronic mail on consent of the person receiving the notice.
- c) Delivery shall be deemed complete as follows:
  1. Upon personal service;
  2. As indicated on the return receipt of any notice mailed by certified mail, return receipt requested;
  3. Three (3) days after deposit in the U.S. mail, postage pre-paid for first class deliver; or
  4. Where the owner or occupant of any property cannot be located after the reasonable efforts any notice shall be deemed delivered after posting on the property for a period of five (5) business days.
- d) Where the recipient of notice is the owner of the property, the address for notice shall be the address from the most recently issued equalized assessment roll for the property or as otherwise appears in the current records of the City.

**ARTICLE 20** (Renumbered as Article 11 by Resolution 5006)

Revised in its entirety – 6/93, 6/94, 6/95, 9/96  
Sec. 20.7, Sec. 20.7.2 – Rev. 6/99  
Sec. 20.6 – Rev. 11/99  
Sec. 20.5.4 & 20.5.5 – Rev. 6/06  
Sec. 20.7.1 & 20.7.2 – Rev. 6/06  
Sec. 20.6.1 – Rev. 10/06  
New Sec, 20.6 – Added 2//07  
Sec. 20.7.5; 20.7.8; 20.8; 20.8.1; 20.8.2 – Rev. 6/07  
20.8.1 – Rev. 3/08  
20.7.2, 20.7.4, 20.7.5, 20.7.6, 20.8, 20.8.2 – Rev. 6/08  
Sec. 20.7.2 – Rev. 8/08  
Sec. 20.8.1, 20.8.2 – Rev. 6/09  
Sec. 20.11 – Rev. 12/10  
Sec. 20.8.2 – Rev. 5/11  
Sec. 20.8.1 – Rev. 6/11  
Sec. 20.8.1 – Rev. 4/12  
Sec. 20.2, 20.4, 20.6.2, 20.6.3, 20.7.1, 20.7.2, 20.7.3, 20.7.4, 20.7.5, 20.7.6, 20.8.2 – Rev. 6/12  
Sec. 20.7.2, 20.7.3 – Rev. 7/12  
Sec. 20.8 – Rev. 6/13  
Sec. 20.8.1, 20.8.2 – Rev. 6/14  
Sec. 20.8.1, 20.8.2 – Rev. 6/15  
Secs. 20.5.2 (add), 20.8.1, 20.8.2 – Rev. 7/16  
Secs. 20.5.2, 20.8, 20.8.2 – Rev. 12/18  
Sec. 20.7.2 – Rev. 7/19  
Revised in its entirety – 8/20  
Sec. 20.16.2, 20.16.4, 20.16.5 – 12/20

**Article 12. Water and Sewer Rates and Service Charges.**

Water and sewer rates and charges are set to fully recover the District's costs. In order to help stabilize the revenue of the District during increasing or decreasing sales, the District has established a policy to collect approximately 80% of the District's fixed water operating costs through the monthly fixed charges and collect the remaining approximately 20% of the District's fixed operating cost through volumetric water rates. The rates and charges are set based upon cost of service principals that meet legal requirements and industry standards.

Effective January 1, 2021, the following rates for water deliveries to each class of service are established:

Sec. 12.1 Volumetric Water, Recycled Water and Pumping Rates.

For purposes of determining water rates, one unit equals 1,000 gallons:

Domestic (D), Large Lot Domestic (LD).

1-5 units per month .....	\$6.83 per unit
6-30 units per month .....	\$6.92 per unit
Over 30 units per month .....	\$8.44 per unit

Commercial (C).

All usage .....	\$7.03 per unit
-----------------	-----------------

Multi-Unit (M) (Tier ranges factor residential units, per Article 10.1).

1 - 5 units per month .....	\$6.83 per unit
6 - 30 units per month .....	\$6.92 per unit
Over 30 units per month .....	\$8.44 per unit

Government (G).

All usage .....	\$6.91 per unit
-----------------	-----------------

Irrigation Only (I).

All usage .....	\$7.04 per unit
-----------------	-----------------

SAWR - Ag Only (AS).

All usage .....\$5.06 per unit

SAWR - Ag & Home (AT).

1-5 units per month .....\$6.83 per unit

6-17 units per month .....\$5.86 per unit

Over 17 units per month .....\$5.06 per unit

Commercial Ag (CA).

All usage .....\$5.86 per unit

Commercial Ag Domestic (CB).

1-5 units per month .....\$6.83 per unit

Over 5 units per month .....\$5.86 per unit

Drought Rates

In order to prepare and manage future periods of water shortage and mandatory conservation, the District adopted a water shortage contingency plan called the Water Shortage Response Program (the “Program”). Pursuant to the Program, the District established four Water Shortage Response Levels. Article 17 Water Shortage Response Program provides information on the program and the applicable water use rates.

Volumetric Recycled Water Rate.

Recycled water furnished within the District service area for any appropriate purpose will be billed at \$5.84 per 1,000 gallons. Recycled water sold outside the District service area will be sold by contract with specific customers. For San Diego County Water Authority and Metropolitan Water District rebate purposes, reclaimed water rates must be set at higher of 85 percent of lowest applicable potable water rate or 80 percent of the average of Tier 1 and Tier 2 rates.

Construction Meter.

Water furnished for construction purposes will be billed at \$8.70 per 1,000 gallons.

Volumetric Pumping Charges. (DSA and Toyon only)

Pumping charges for the DeLuz High Pressure Service Area and Toyon Heights shall be furnished at \$0.84 per 1,000 gallons to recover the cost of electricity.

Sec. 12.2 Monthly Fixed Charges.

Effective January 1, 2021, the following rates and charges are established and shall be collected by the District for water and recycled water service:

Monthly Service Charges for each meter (\$/meter size):

	Water Fixed Charges	Recycled Water Charges	Standby Service Charge	Private Fire Services Charge
3/4 inch meter	\$53.52	\$24.02	\$24.02	NA
1 inch meter	\$81.70	\$32.52	\$32.52	NA
1-1/2 inch meter	\$152.12	\$53.77	\$53.77	NA
2 inch meter	\$236.65	\$79.27	\$79.27	\$11.67
3 inch meter	\$462.01	\$147.29	\$147.29	\$12.44
4 inch meter	\$715.55	\$223.81	\$223.81	\$13.78
6 inch meter	\$1,419.85	\$436.34	\$436.34	\$18.57
8 inch meter	NA	NA	NA	\$26.84

NA- Not applicable

For construction meters, a service charge of \$354.98 per month or fraction thereof will be made in addition to the cost of water consumed. This rate is calculated using a factor of 1.5 times the fixed charge for a 2” water meter.

The foregoing fixed charges for water service through various sized meters that are installed or upgraded will be effective commencing the day of installation, regardless of the amount of water used, as long as the consumer's property is actually connected with the District's distribution system. In addition, any request to down size a meter properly filed with the District will receive a fixed charge commensurate with the meter size effective the next billing cycle.

Billings for water furnished to all accounts will be on a monthly basis.

A monthly service charge to cover the District's cost for annual inspection, maintenance, repair and replacement of backflow prevention devices will be made as follows (\$/meter size):

For each 3/4 inch device	\$5.90
For each 1 inch device	\$6.95
For each 1-1/2 inch device	\$12.86
For each 2 inch device	\$15.42
For each 3 inch device	\$30.81
For each 4 inch device	\$48.15
For each 6 inch device	\$96.28

Sec. 12.3 MWD Readiness-to-Serve Charge (RTS) and SDCWA Infrastructure Access Charge (IAC).

Effective January, 2021, the following monthly charges are established and shall be collected by the District for the Metropolitan Water District of Southern California’s Readiness-to-Serve (the “RTS”) charge and San Diego County Water Authority’s Infrastructure Access Charge (the “IAC”).

Monthly charges for each meter (\$/meter size):

	RTS	IAC
3/4 inch meter	\$1.95	\$3.64
1 inch meter	\$3.26	\$6.08
1-1/2 inch meter	\$6.49	\$12.12
2 inch meter	\$10.39	\$19.40
3 inch meter	\$20.81	\$38.86
4 inch meter	\$32.51	\$60.72
6 inch meter	\$64.99	\$121.39

Sec. 12.4 Water Capital Improvement Charge.

For each water account, an additional \$9.77 per month per Equivalent Meter Unit (EMU) shall be added as a Capital Improvement Charge effective January 1, 2021. This charge is solely dedicated to funding water capital improvement projects. The Water Capital Improvement Charge (the “CIC”) was implemented to provide a partial funding source for capital projects like the UV treatment facility at the Red Mountain Reservoir and to fund pipeline replacement projects.

Water Capital Improvement Charges will be adjusted annually based on the ENR (Engineering News Record) Construction Cost Index (CCI) of February, plus 3% not to exceed 10%. Staff will report back to the Board of Directors no less than every five (5) years with analysis of its necessity. The Capital Improvement Charge will be used to fund capital improvement projects or debt service for capital improvement projects. Revenue from the Capital Improvement Charge will not be used to fund Operating Costs.

Fallbrook Public Utility District’s Equivalent Meter Unit (EMU) is associated with meter size as listed below.

Meter Size	FPUD EMU	Water CIC	Water CIC (Standby Service)
3/4 inch meter	1.0	\$9.77	\$4.42
1 inch meter	1.67	\$16.27	\$7.37
1-1/2 inch meter	3.33	\$32.55	\$14.75
2 inch meter	5.33	\$52.07	\$23.60
3 inch meter	10.67	\$104.14	\$47.19
4 inch meter	16.67	\$162.72	\$73.73
6 inch meter	33.33	\$325.43	\$147.46

An additional, a Water CIC Pumping charge of \$.10 per 1,000 gallons is charged and allocated to capital improvements for the DeLuz High Pressure service area and Toyon Heights zone. This Capital Improvement Charge will be adjusted annually based on the ENR (Engineering News Record) Construction Cost Index (CCI) of February, not to exceed 10% annually.

Sec. 12.5 Billing Periods.

Billing due dates fall on the 10th, 20th, and 30th of the month depending on meter location in the District. All charges for water and sewer services during specified meter read dates are due and payable when rendered. Bills become delinquent the day after the due date. Residential accounts not paid within 30 days of the due date are sent past due statements and the meters are subject to lock-up for non-payment (See District Residential Discontinuation of Service Policy available on the District website). Non-Residential accounts not paid within 30 days of the due date are subject to meter lock-up. All water accounts accrue a \$30 Delinquent Processing Fee on the 31st day of delinquency.

Accounts not paid within 30 days after lock-up and accounts that have tampered with the meter to obtain water illegally are subject to removal of meters and permanent disconnection of water service. Standby charges will continue to accrue after the meter has been removed.

If a meter has been locked for non-payment for a period of 90 days, it may be placed on Standby Service by FPUD. Standby Service charges will accrue from that time until an application for service restoration has been received by the District.

The District must be notified in a timely manner with the name and mailing address of the new owner or tenant and the upcoming date of transfer. Notification of the transfer of property ownership, or tenancy, is the responsibility of the owner/seller. The District is not responsible for the proration of the final billing if notification is not received prior to the date of sale, or change of tenancy.

Sec. 12.5.1 Unclaimed Funds

Unclaimed funds in an amount less than \$15 or where the depositor's name is unknown will become FPUD general funds if unclaimed for 1 year. Unclaimed funds in an amount greater than \$15 become may become FPUD general funds once the following procedure is completed:

1. The FPUD treasurer will publish notice once a week for two (2) successive weeks in a newspaper of general circulation published within FPUD boundaries.
2. The notice will state the amount of unclaimed money, the formal name of the fund in which the money is held, and a statement that the money will become FPUD property after a specified date ("Effective Date"). The Effective Date will be no less than forty-five (45) days nor more than sixty (60) days of the date of the first publication of the notice ("Claim Period").
3. Upon the expiration of the Claim Period, and if there are no claims filed with FPUD or verified lawsuits filed with the superior court, the funds will become FPUD property and may be transferred to FPUD's general fund.

Any person with a claim to such money may file a claim prior to the Effective Date with the FPUD treasurer. Pursuant to Government Code Section 50052, the claim shall include



the following information: claimant’s name, address, amount of claim, grounds upon which the claim is founded, and any other information that may be required by the FPUD treasurer. FPUD has the right to accept or reject a claim. If the claim is accepted, FPUD will return the money without interest. If FPUD rejects the claim, the claimant may file a verified complaint against FPUD with the superior court within thirty (30) days of receiving notice of FPUD’s rejection pursuant to Government Code Section 50052. In the event that the original customer or depositor is deceased, such person’s heir, beneficiary, or duly appointed representative may file a claim before the Effective Date as provided in Government Code Section 50052.5.

Sec. 12.6 Meter Locks and Restrictors.

If for any reason, other than District convenience, a water meter shall be locked by the District, the water may not be again turned on to serve the property through such meter until all past due charges plus the Disconnection Processing Fee of Fifty Dollars (\$50) shall have been paid to the District. A Delinquent Processing Fee of \$30 to process and deliver delinquent account notices and a fee of \$100 for broken or damaged locks may also apply. Damage to corporation or angle stop in attempt to restore services locked for non-payment will be billed at actual time and material and added to the water bill.

If flow restrictors are required for any reason in order to implement policies within this Administrative Code, the fees are as follows:

<u>Meter Size</u>	<u>Installation Fee</u>
3/4” and 1” Meters .....	\$137
1-1/2” and larger .....	\$582

Sec. 12.7 Meter Not Registering.

Whenever, for any reason, a meter fails to register correctly, the consumer will be charged an amount for the previous billing period increased or decreased by the percentage change in total billing by the District for all consumers for the two billing periods.

Sec. 12.8 Water Rates or Service Charges Lien on Property.

In addition to any other remedy provided therein or by law for the collection of any water rate, charges or account, all rates or service charges provided for in this Administrative Code shall be charged and become a charge against the property on which the water is furnished and against the owner thereof, and all charges for water so served to a property shall be and become a lien against the premises upon which the water is used or served.

Standby accounts with a delinquent balance greater than \$500 as of April 1<sup>st</sup> of each year may be sent notification of intent to place delinquent and unpaid charges on the annual tax roll. The notification will be sent by May 1<sup>st</sup> and provides the customer 60 days to bring the account current. If the amount is not brought current by July 1<sup>st</sup>, the portion of the delinquency due as of the prior April 1<sup>st</sup> may be reported to the County Treasurer for inclusion on the annual taxes levied on the property.

If for any reason or cause the sums of money owing for such water services are not paid as required by the terms and provisions of this Administrative Code, the District shall have the right to shut off such water, and in no case shall service of water be resumed on the same property until all such delinquencies and additional turn-on charges shall have been paid in full. Delinquent bills from former owners or tenants are the responsibility of the present owner.

Sec. 12.8.1 Theft of Water.

Water is defined as stolen from the customer if the water is stolen from the customer's side of the meter. Water stolen from a mainline, hydrant, District pipeline, appurtenance, or tampering with a customer's meter is defined as water being stolen from the District.

Water Stolen from Customer.

Customers who have reported water theft to the District must also notify local law enforcement agencies. The District will require proof of theft from a law enforcement agency that a theft of water occurred. Customer's asking for credit on the bill for water theft will be processed by account type. If a full price M&I customer, the District may discount the estimated amount of water stolen and charge the District's wholesale cost of water for the amount stolen. An estimate of the amount of water stolen will be made by District staff using that customer's usage history. Water sold to agricultural customers, SAWR, and Commercial Ag/Commercial Ag Domestic, is sold at District cost so no discount may be applied. If the stolen water caused the customer's allocation bank to be adversely affected, the District will restore the estimated amount stolen to the customer's allocation bank. If the water theft resulted in an overuse penalty, the District will credit the penalty to the customer for the estimated amount of water stolen.

Water Stolen from District.

Any theft of water from the District will be reported to law enforcement agencies. If the theft is due to meter tampering, the customer will be charged a \$250 fee for tampering with the meter plus time and materials to place the meter back into proper position. If a water theft from the District due to meter tampering occurs again on the same meter, the customer will be charged a \$500 fee for tampering and an item will be brought forward to the Board of Directors to consider discontinuance of service. An estimate of the amount of water stolen will be calculated and billed to the customer's account. Collection of said fees are subject to all District regulations regarding collection of past due accounts.

Sec. 12.9 Volumetric Wastewater Charges.

Wastewater service charges are established upon each property within the District that is connected to a sewer line of the District whether said premises are occupied or unoccupied. Volumetric Wastewater Charges are applied to estimated billable wastewater flows, which are based upon adjusted water deliveries. The charge per killogallon of wastewater flow is shown below:

User Class	Volumetric Wastewater Charge (\$/kgal)
Ag. Domestic	\$ 10.79
Commercial Ag. Domestic	\$ 10.79
Residential (Single , Multi-family)	\$ 10.79
Government	\$ 10.72
School	\$ 10.72
Church	\$ 10.72
Commercial – Low Strength*	\$ 10.72
Commercial – Medium Strength*	\$ 13.22
Commercial – High Strength*	\$ 16.48

Appendix A to this Article provides commercial effluent classification.

For the purpose of determining the billable wastewater flows, water deliveries must be converted to wastewater flows returned to the sewer system. To do this conversion, a Return to Sewer Factor is applied. The Return to Sewer factor adjusts the water received by the meter to the estimated flows from the residence or entity into the sewer system. The Return to Sewer Factor applied to the different customer classes are shown below:

Cusomer Class	Return to Sewer Factor
Residential (Multi-Family, Single Family)	75%
Non-Residential/Commercial	90%
Low / Medium / High	90%
Government	
Low / Medium / High	90%
Schools	80%
Churches	80%
Special	
Low / Medium / High	100%
Special 10% RTS (1-10%)	
Low / Medium / High	10%
Special 20% RTS (11-20%)	
Low / Medium / High	20%
Special 30% RTS (21-30%)	
Low / Medium / High	30%
Special 40% RTS (31-40%)	
Low / Medium / High	40%
Special 50% RTS (41-50%)	
Low / Medium / High	50%
Special 60% RTS (51-60%)	
Low / Medium / High	60%

Customer Class	Return to Sewer Factor
Special 70% RTS (61-70%)	
Low / Medium / High	70%
Special 80% RTS (71-80%)	
Low / Medium / High	80%

Non-residential customers with higher outdoor are evaluated on a case by case basis.

For those Single Family Residences (D, LD, AT, CB), volumetric charges are calculated as follows:

1. The 2-year average winter use is calculated based upon prior year water deliveries that include December, January and February. The average used for wastewater billing is capped at 21.33 units.
2. 75% of this water is assumed to be returned to sewer/billable flow.
3. The Volumetric Wastewater Charge (\$/kgal) is applied to this flow.
4. Consumption analysis is performed annually. Appeal for consumption is available.
5. No prior history customer (new customer) will be placed at that customer class median of 6. For customers with at least one winter of use data, that data will be used for the their winter average.
6. Use must be > 0 unless customer is on standby.

For those Multi-Family Residences (M), volumetric charges are calculated as follows:

7. The average winter use is calculated based upon prior year water deliveries that include December, January and February.
8. 75% of this water is assumed to be returned to sewer/billable flow.
9. The Volumetric Wastewater Charge (\$/kgal) is applied to this flow.
10. Consumption analysis is performed annually. Appeal for consumption is available.
11. No prior history customer (new customer) will addressed on a case by case basis.

All other water customer classes (G, C, A,, AS, CA), with the exception of public elementary and public junior high schools:

1. Monthly sewer bill based on actual water sold.
2. The Return to Sewer factor applied to determine the billable flow. Appeals for irrigation and/or water usage which does not get returned to the sewer is available.
3. Customer is classified as high, medium, or low strength (based upon BOD and SS). See attached Appendix A. Appeal for strength classification is available.
4. The applicable Wastewater Volumetric Charge is applied to the billable flow.

Public elementary and public junior high schools:

1. Monthly sewer bill based on per person, per month charge.
2. The public elementary and / or public junior high school district to provide a report each October that documents the number of students and faculty at each site.
3. CY 2021 public elementary school rate is \$1.31 per student and \$1.91 per staff, per month.
4. CY 2021 public junior high school and administrative offices rate is \$1.91 per person, per month.
5. Rates to be increased by the overall percentage increase in wastewater revenues each year.

Sec. 12.10 Monthly Fixed Wastewater Charge.

For each sewer account, Effective January 1, 2021, the Monthly Fixed Wastewater Charge shall be \$10.60 per month per Equivalent Dwelling Unit (EDU). EDUs will be calculated per Administrative Code Sections 11.7.2, 11.7.3, or 11.7.4.

Sec. 12.10.1 Wastewater Capital Improvement Charge.

For each account, an additional \$11.63 per month per Equivalent Dwelling Unit (EDU) shall be added as a Wastewater Capital Improvement Charge Effective January 1, 2021. This charge is dedicated to Wastewater Debt Service and Wastewater Capital Improvements. The Wastewater Capital Improvement Charge has been implemented to partially fund the debt service payments for upgrades to the Wastewater Treatment Plant. EDUs will be calculated per Administrative Code Sections 11.7.2, 11.7.3, or 11.7.4. This Capital Improvement Charge will be adjusted annually based on the ENR (Engineering News Record) Construction Cost Index (CCI) of February, not to exceed 10%. Staff will report back to the Board of Directors every five (5) years with analysis of its necessity. The Capital Improvement Charge will only be used to fund capital improvement projects or debt service for capital improvement projects. Revenue from the Capital Improvement Charge will not be used to fund Operating Costs.

**ARTICLE 21** (Renumbered as Article 12 by Resolution 5006)

Sec. 21.1 – Rev. 7/02  
Sec. 21.2-21.8.2 – Rev. 9/96  
Sec. 21.3 – Rev. 10/96  
Sec. 21.4 & 21.9 – Rev. 6/97  
Sec. 21.4 – Rev 7/02  
Sec. 21.9 – Rev. 10/97  
Sec. 21.9 – Rev. 6/04  
Sec. 21.9 – Rev. 1/05  
Sec. 21.1, 21.3, 21.4, 21.9 – Rev. 6/05  
Sec. 21.1, 21.2, 21.4, & 21.9 – Rev. 6/06  
Sec. 21.9, Flat Rate + Metered Flow – Rev. 7/06  
Sec. 21.9 (Flat Rate classification) – Rev. 10/06  
Sec. 21.4 (construction meters), Sec. 21.5 & Sec. 21.6 – Rev. 12/06  
Sec. 21.5 – Rev. 3/07  
Sec. Sec. 21.1, 21.2, 21.4 , 21.10, 21.10.1– Rev. 6/07  
Sec. 21.5 – Added 6/07  
Sec. 21.10.2 – Deleted 6/07  
Sec. 21.11 – Added 10/07  
Sec. 21.4.1 – Added 12/07; Sec. 21.7 renamed and addition of flow restrictors – Rev. 12/07  
Sec. 21.1, 21.2, 21.4, 21.5, 21.7, 21.10, and 21.11 – Rev. 6/08  
Sec. 21.1, 21.2, 21.4, 21.4.1, 21.4.2 (added), 21.5, 21.7, 21.10 (new table), 21.10.1, - Rev. 6/09  
Sec. 21.4, 21.10 – Rev. 12/09  
Sec. 21.6, 21.9 – Rev. 5/10  
Sec. 21.1, 21.2, 21.4, 21.4.1, 21.4.2, 21.5, 21.10, 21.10.1 – Rev. 6/10  
Sec. 21.9.1 (added) – Rev. 9/10  
Sec. 21.1, 21.4, 21.4.1, 21.4.2, 21.5, 21.10, 21.10.1 - Rev. 6/11  
Sec. 21.1, 21.2, 21.4, 21.5, 21.10, 21.10.1 – Rev. 6/12  
Sec. 21.1, 21.2, 21.4, 21.5, 21.10, 21.10.1 – Rev. 6/13  
Sec. 12.1, 21.2, 21.4, 21.5, 21.9.1, 21.10, 21.10.1 – Rev. 6/14  
Sec. 21.1, 21.2, 21.5 – Rev. 1/15  
Sec. 21.1, 21.2, 21.3, 21.4, 21.4.2, 21.5, 21.10, 21.10.1 Rev 6/15  
Sec. 21, 21.1 – Rev. 11/15  
Secs. 21, 21.2, 21.4, 21.5, 21.7, 21.10, 21.10.1 – Rev. 7/16  
Secs. 21, 21.1 - Rev. 12/16  
All Secs. – Rev. 12/17  
Sec. 21.3 – Rev. 6/18  
Secs. 21.1, 21.2, 21.3, 21.4, 21.9, 21.10, 21.10.1 – Rev. 12/18  
Sec. 21.3 – Rev. 6/19

**ARTICLE 21 CONTINUED**  
(Renumbered as Article 12 by  
Resolution 5006)

Secs. 21, 21.1, 21.2, 21.3, 21.4,  
21.5, 21.9, 21.10, 21.10.1 – Rev  
12/19

Secs. 21.5, 21.6, 21.5.1 (added) –  
Rev. 1/20

Sec 21.3 – Rev 6/20

Secs. 21, 21.1, 21.2, 21.3, 21.4,  
21.9, 21.10, 21.10.1 – Rev 12/20

**Article 13.**            **Easements.**

Sec. 13.1            **Requirement for Easements.**

Whenever a pipeline is constructed, a meter is installed, an extension of a line is made, or a fire hydrant installed, the District requires an easement in order to go on the property.

Sec. 13.2            **Acceptance of Easements.**

The District accepts easements for right-of-way for District pipelines and facilities, together with right of ingress and egress for the purpose of construction, repairing, relaying, enlarging and operating same.

On January 26, 1987, the Board of Directors authorized the General Manager to approve all easements received and the President and Secretary to sign them and prepare them for recordation upon the necessary information provided by the legal owner.

Sec. 13.3            **Granting of Easements.**

Granting of easements must be approved by the Board of Directors. Staff will determine whether the District will grant an easement over District property or over easements the District has that allows for reconveyance to others.

<b>ARTICLE 22 (Renumbered as Article 13 by Resolution 5006)</b>
Sec. 22.3 – Rev. 6/93
Sec. 22.1 – Rev. 11/94
Sec. 22.3 – Rev. 6/95
Sec. 22.1-22.3 – Rev. 9/96



**Article 14.**                    **Construction, Regulations Governing.**

Sec. 14.1            Water Line Extensions and Replacements by the District.

As finances permit, the District will repair and replace the system of mains, storage reservoirs, pumps and controls that are existing, maintained, and operated by the District. Storage reservoirs connected by these mains will be located at convenient high points within the District so that reasonable pressures under gravity flow can be provided to the consumers around them. Pressures higher than those available under gravity flow will not be provided by the District except as may be considered under a special rate Ordinance.

Extensions desired beyond the existing system in service shall be provided by others desiring the extensions.

The District can fund pipeline looping projects, when all properties are served and a short pipeline section is needed to loop the end of the pipeline to another pipeline in the distribution. When this occurs in a subdivision or other development project, the project plans of improvement must include all District pipeline improvements, both private and District funded portions, prior to being approved by the District.  
*Ordinance No. 226.*

Sec. 14.2            Water Line Extensions, privately financed.

The following terms and conditions shall apply to extensions and others who provide them:

- a) An extension, at the expense of others, may be required as a condition of service where the property to be served does not abut a District pipeline. A required pipeline extension shall extend a minimum of 20 feet beyond the property line into the property.
- b) An extension, at the expense of others, shall be required as a condition of service where the property to be served does not abut a District pipeline and where the land is to be part of a subdivision or a similar development. For minor subdivisions (5 parcels or fewer) the pipeline extension shall extend a minimum of 20 feet into the last parcel to be served.
- c) The District will accept, maintain and operate those extensions constructed to its standards and requirements by others. Whenever an extension is to be provided by others, it shall conform to the then current Standard Specifications for Distribution System Construction, as approved by the Board of Directors.
- d) The location of all extensions and service connections shall be at the discretion of the District.
- e) Whenever it is not possible for an extension provided by others to lie within a County Road, the District shall require that an easement, normally thirty (30) feet in width, be provided, which will enable the District to maintain and replace the pipeline.
- f) An extension to serve a major subdivision (greater than 5 parcels) or other property being similarly developed may be required to the far edge of the last lot served.

- g) All extensions shall be constructed with pipe of a size adequate in the judgment of District staff to serve the area and the minimum size shall be six (6) inches.
- h) Fire hydrant installations as required by the North County Fire Protection District and then existing ordinances of San Diego County shall be provided as an integral part of all extensions.
- i) The District can approve exceptions to these requirements in the form of a Remote Meter Agreement per Section 10.2 or a Temporary Service Agreement per Section 10.3.

Sec. 14.3      Repayment Agreements - Water and Sewer Line Improvements.

Improvements provided by others which benefit owners fronting upon but not contributing toward the cost at the time of construction may be subject to a privately financed extension agreement for the collection and refunding of part of the cost. The Agreement consists of the following:

- a) The District will have title to the improvements and will operate and maintain them as a part of the District's system.
- b) The District agrees to collect a proportionate contribution for the cost of the improvements to provide service to those adjoining lands benefiting from them for a period of 10 years or until all proportionate charges have been collected and refunded, whichever period is less.
- c) The District agrees to refund to the financing owners the proportionate contribution funds that are collected.
- d) The District will have the sole authority to permit connections to or extensions from and service connections to said privately financed improvements.
- e) The basis upon which proportions of the cost of the improvement(s) shall be computed for each privately financed extension agreement shall be negotiated by the Board of Directors with the financing owners and shall generally consist of practicable front footage, acreage, number of service connections, or such other basis as may be determined by the Board of Directors to be equitable to the financing owners and other benefiting property owners.
- f) The improvement(s) will be installed in an easement granted to the District free of liens and encumbrances.

14.3.1      Administrative Costs. The administrative cost to the financing owners shall be one hundred dollars (\$100) and shall be collected by District at the time such privately financed extension agreement is entered into.

Payment for District service(s) that has been used on any parcel of land shall have been made in full before the parcel is to be eligible to receive service from a new extension or service connection.

Sec. 14.4      Pipeline Extensions - Sewer.

- 14.4.1 Process. If an Applicant seeks an application for sewer service for property which is not adjacent to a District sewer system pipeline, the Applicant shall be required to enter into a written agreement with the District to construct additional facilities determined necessary by the District at the time the application is submitted.
- 14.4.2 Agreement. No pipeline extension shall be allowed unless the Applicant executes the agreement entitled "Agreement for Construction of Sewer Facilities to be Dedicated to the Fallbrook Public Utility District".
- 14.4.3 Fees. For line extensions, the Applicant shall pay the District a cash deposit computed as follows:
- (a) Inspection fees of \$5 per lineal foot;
  - (b) One hundred fifty percent (150%) of the District's estimate of the total construction costs for the line extension, or one hundred fifty percent (150%) of the actual bid secured by the applicant for the work, if lower.

Sec. 14.5 Construction Ownership and Maintenance of Sewer Lateral Pipelines.

The sewer lateral pipeline is that portion of the service lateral between the connection to the common sewer main and the service cleanout, located typically at the edge of the right-of-way where it connects with the owner lateral.

The installation of sewer lateral pipelines and connection of sewer lateral pipelines to the sewer main transmission lines of the District shall be done only by personnel of the District. The District is authorized to contract for such installation and connection when personnel of the District are not available to install and connect the lateral pipeline. The contract work shall be inspected and approved by the District before acceptance of the work by the District.

The entire sewer lateral pipeline and owner lateral from the connection to the common sewer main to the house connection shall belong to and be the property of the Owner. The common sewer main, including all manholes and appurtenances, shall belong and be the property of the District. The District may maintain that portion of the Owner's lateral between the common sewer main and the service cleanout upon the request of the Owner. The District may repair that portion of the Owner's lateral between the common sewer main and the service cleanout upon the request of, and at the expense of, the Owner.

Sec. 14.6 Temporary Sewer Service Connections.

A Temporary Sewer Service Agreement is a recorded agreement between the District and a consumer that a connection will be placed temporarily at a location which must be pumped to serve the property, where the District intends, at some future date, to extend the District collection system to abut, or cross, the property described in the agreement, and that the consumer is responsible for extending his own temporary private lateral from the main to his property, obtaining whatever temporary easements are required for such extension, and maintaining private pump stations in a sanitary fashion, free of odors. Such agreements shall establish the financial obligations of the consumer related to the future installation costs of the District's collection system and the cost of connection to the gravity main, and shall be binding upon the signatory and all successor owners of said property.

Failure to comply with the terms of the agreement shall be cause for termination of sewer service to said property and the basis for establishing a lien against the property for collection of any amounts due the District. Upon change of ownership, any parcel receiving sewer service under a Temporary Sewer Service Agreement will be required, as a condition of continued service, for the new owner to enter into a new Temporary Sewer Service Agreement with the District.

ARTICLE 23 (Renumbered  
as Article 14 by Resolution  
5006)

Sec. 23.1 – Rev. 7/94

Sec. 23.4 – Rev. 6/95

Sec. 23.5.2 – Rev. 9/96

Sec. 23.3 - Rev. 1/99

Sec. 23.5, Sec. 23.5.1- Rev.  
6/99

Sec. 23.6 – Added 11/99

Sec. 23.5 – Rev. 1/01

Sec. 23.5 – Rev. 6/07

Secs. 23.1, 23.2 – Rev. 7/19

**Article 15.**                    **Standby or Availability Charges**

Sec. 15.1            Definition.

In accordance with Division 7, Chapter 4, Article 3, Sec. 16475 and 16477 of the Public Utility District Act, the Board of Directors has the authority to establish standby or water availability charges, not to exceed \$30.00 an acre.

Sec. 15.2            Water Availability Charges.

Water availability charges are hereby fixed and established on all land within the District boundaries, whether the water is actually used or not, as follows:

The term "parcel" as used herein shall mean a parcel of land as shown upon the assessment rolls of the County Assessor of San Diego County; provided that where a legal final subdivision map has been approved, "parcel" shall mean each separate lot within the subdivision.

15.2.1            Fallbrook Service Area.

(a) \$10 (ten) per acre for all parcels one (1) acre or more prorated out to one hundredth of an acre, as set forth in the San Diego County Tax Assessor's maps, EXCEPTING lands permanently dedicated exclusively to transportation of persons or property, hereafter referred to as the transportation dedication exclusion. For purposes of this Administrative Code, it is assumed that 5% of all parcels have been permanently dedicated exclusively to transportation of persons and property; therefore, the actual assessment will be \$9.50 per gross acre, as set forth in the San Diego County Tax Assessor's maps.

(b) \$5 (five) for parcels of less than one acre. For purposes of this Administrative Code, all parcels with gross acreage of 1.05 acres are considered to have a net acreage of less than one acre for purposes of the transportation dedication exclusion.

15.2.2            DeLuz Improvement District.

(a) Acreage adjacent to or lying within 1320 feet of water distribution line \$10.00 per acre.

(b) Acreage between 1320 and 2640 feet of a water distribution line – \$ 9.00 per acre.

(c) Acreage between 2640 and 3960 feet of a water distribution line – \$ 8.00 per acre.

(d) Acreage between 3960 and 5280 feet of a water distribution line – \$ 7.00 per acre.

(e) Acreage over 5280 feet from water distribution line -\$ 6.00 per acre.

(f) All parcels of less than one acre - \$ 5.00.

Sec. 15.3      Exemptions.

Lands not using District water and obtaining water primarily from rainfall, springs, streams, lakes, rivers, or wells, and where the primary economic activity on the land is the commercial extraction of minerals, are exempt.

Sec. 15.4      Collection of Standby/Availability Charges.

On or before August 10 of each year, the Secretary of the District shall furnish in writing to the Board of Supervisors of San Diego County and to the County Auditor a description of the land within the District upon which standby or availability charges are to be levied and collected, together with the amount of the charges. At the time and in the manner required by law for the levying of taxes for County purposes, the Board of Supervisors shall collect, in addition to taxes it levies, water availability charges in the amounts fixed by this Administrative Code for the respective parcels of land described in Sec. 14.2.1 and Sec. 14.2.2 of this Code. All County officers charged with the duty of collecting taxes will collect the charges with the regular tax payments in the same form and manner as County taxes are collected. Such availability charges are a lien on the property with respect to which they are fixed. Collection of the charges may be enforced by the same means as provided for the enforcement of liens for State and County taxes.

Sec. 15.5      Deferral of Charge.

Situations may arise when an owner of a parcel of land does not use and has no present intention of using water provided by the District, a member agency of the San Diego County Water Authority. The purpose of this section is to permit an evaluation by the District, on a case-by-case basis, of the circumstances which pertain to such situations to determine whether a deferral of charges should be approved according to the terms and conditions herein provided.

15.5.1      Application. Any owner of a parcel of land who believes that the amount of the Water Standby Availability Charge fixed against such parcel should be deferred may file an application with the District for deferral of the charge, as follows:

- a) The application shall include a statement describing the circumstances and factual elements which support the request for deferral.
- b) The General Manager shall consider the request within sixty (60) days after the filing of a completed application. If the application for deferral meets the established criteria, the General Manager may decide whether to approve the request and order the charge deferred accordingly. If the request is denied, the applicant shall be notified in writing stating the reasons for the denial.
- c) An application shall be deemed timely as to a charge established for any year if it is filed within three (3) years after the date the ordinance fixing the charge is adopted.

15.5.2 Appeal to Board of Directors. If the General Manager denies a request, the owner may file an appeal with the Board of Directors within sixty (60) days after such denial. No new application for deferral need be considered by the General Manager until expiration of twelve (12) months from the date of a denial unless differently directed by the Board of Directors.

15.5.3 Deferred Charges on Restricted Parcels. The levy of the charge may be deferred annually as to any parcel of land which meets each of the following criteria:

a) The owner of such parcel makes a timely application requesting deferral of the charge as defined in subsection 15.5.1.

b) The parcel, which is the subject of the request, will become subject to enforceable restrictions which prohibit the use of water on the parcel, except by means of natural precipitation or runoff; provided however, if considered appropriate by the General Manager local water may be used for limited domestic, stock watering and irrigation uses.

c) The owner executes a recordable agreement which includes provisions that:

set forth the enforceable restrictions pertinent to the subject parcel;

the agreement may be terminated upon written request by the owner and payment of all deferred Water Standby Availability Charges, plus interest thereon, compounded annually, and accruing at the legal rate from the date such charges would have been otherwise due and payable;

no water service from District sources shall be provided to such parcel for a period of ten (10) years after the total amount due for the charges deferred, plus annually compounded interest, is paid in full to the District;

during the ten (10) year period, while water service is not available to the subject land, the owner pays all annual Water Standby Availability charges as fixed; and

contains such other provisions considered by the General Manager to be appropriate.

15.5.4 Deferred Charges on Partial Parcels. The District does not allow partial deferments of the Water Availability/Standby charge on a single parcel. Landowners within the District's service area wishing to defer these charges on a portion of their property will need to obtain a separate Assessor Parcel Number (APN) for that property that cannot be developed or planted.

A property owner must submit a map to the San Diego County Assessor's Office, Mapping Division, depicting the owners property and the area(s) to be considered separately, and a request that the Water Availability/ Standby charge be deferred. This will create a new APN and an Owner's Map which is for assessment purposes only.

15.5.5 Surcharge. Upon termination of the deferral agreement, an owner may elect to receive water prior to the expiration of the ten (10) year period upon payment of a surcharge. The surcharge shall be equal to the amount of the annual water Standby Availability Charge fixed for the parcel(s) of land in the year of election to receive water service multiplied by the number of years remaining of the ten (10) year period.

15.5.6 Refunds. If it is determined that a refund of any previously fixed Water Standby Availability Charge is appropriate because the subject parcel qualifies for deferral of charges, the amount refunded shall be added to the amount of deferred charges due under section 15.5.3, c, para. 2, and will be subject to the legal interest rate compounded annually.

15.5.7 Enforcement Procedures. In order to insure that terms and conditions of the recordable agreement are being met, the General Manager shall:

a) maintain a record of all parcels approved for deferral of the Water Standby Availability Charge;

b) make a written report to the Board of Directors in August of each calendar year showing all parcels with deferred annual Water Standby Availability Charges and the amount of the deferred charges and accrued interest;

c) cause each such parcel to be physically inspected every three (3) years from the date of deferment;

d) report to the Board of Directors any instances where the terms of the agreement are being violated; and

e) take such other actions or procedures considered appropriate.

Sec. 15.6 Certified Copies.

The Secretary of the District shall deliver certified copies of this Ordinance to the Board of Supervisors and to the Auditor of San Diego County with the list of charges described above.



Sec. 15.7      Correction of Errors.

The General Manager of the District is hereby authorized to correct any clerical error made in any assessment or charge pursuant to this Administrative Code to make an appropriate adjustment in any assessment or charge made in error.

*Ord. No. 218, 225, 232, 246, 256, 261, 285, and 295.*

**ARTICLE 24 (Renumbered  
as Article 15 by Resolution  
5006)**

Sec. 24.5.4 – Rev. 9/97

**Article 16.**

**Tax Levy**

Sec. 16.1 Definitions.

Annually, during the Budget process, the Board of Directors makes a determination whether or not budgeted revenues are adequate to pay both the District's budgeted expenditures of the Utility Fund, and the annual principal and interest available on the bonded debt. The District's taxpayers have agreed to pay by taxation any principal and interest on general obligation bonded indebtedness at the time of the bond authorization election. If the Board determines that other revenues are insufficient to meet the debt obligation, then it is necessary for the District to raise money by taxation for the purposes of paying the principal of and interest on the bonded debt of the District as they become due.

Sec. 16.2 General Bonded Indebtedness.

The Fallbrook Public Utility District will have no principal and interest due on general obligation bonded indebtedness during the current fiscal year.  
*Ordinance No. 257, 262, 267, 270, 275, 277, 282, 286, 289, 292, 296, 310, 314, 317.*

Sec. 16.3 Money to be Raised By Taxation.

The Board of Directors has determined that it will not be necessary to raise by taxation during fiscal year 2007-08 any amount for payment of principal and interest on general obligation bonded indebtedness. *Ordinance No. 257, 262, 267, 270, 275, 277, 282, 286, 289, 292, 296, 310, 314, 317.*

Sec. 16.4 Full Valuation of Taxable Property.

It will not be necessary to set a tax levy for fiscal year 2007-08.  
*Ordinance No. 257, 262, 267, 270, 275, 277, 282, 286, 289, 292, 29, 310, and 314.*

Sec. 16.5 Certified Copies.

The Secretary of this Board is not required to immediately transmit to the County Auditor of San Diego County a certified copy of this Ordinance, as no principal and interest is due on general obligation bonded indebtedness for the Fallbrook Public Utility District for the fiscal year 2007-08.

ARTICLE 25 (Renumbered as Article 16 by Resolution 5006)  
Sec. 25.1, 25.2, 25.3, 25.4 & 25.5 – Rev. 7/93  
Sec. 25.2, 25.3, & 25.4 – Rev. 7/94, 7/95, 7/96, 7/97, 7/98, 7/99, 7/00, 7/01, 7/02, 7/03, 7/04, 7/05, 7/06, 7/07

**Article 17.**                    **Water Shortage Response Program.**

Sec. 17.1                    Declaration of Policy.

California Water Code Sections 375 et seq. permit public entities which supply water at retail to adopt and enforce a water conservation program to reduce the quantity of water used by the people therein for the purpose of conserving the water supplies of such public entity. The Board of Directors hereby establishes a comprehensive water conservation program pursuant to California Water Code Sections 375 et seq., based upon the need to conserve water supplies and to avoid or minimize the effects of any future shortage.

Sec. 17.1.1                PSAWR Reduction Program.

The San Diego County Water Authority Permanent Special Agricultural Water Program (PSAWR) provides discounted wholesale supply and treatment pricing for qualified agricultural users within its service area on the basis that participants receive non-firm, interruptible supply up to the maximum allowed per the SDCWA Administrative Code. During periods of water shortages imposed by the Metropolitan Water District (MWD), the SDCWA, or due to emergency situations, those customers who are participating in the PSAWR shall abide by the conditions set forth by SDCWA. Administration of the PSAWR Program is incorporated by reference in Article 10 of this Administrative Code.

Sec. 17.1.2                PSAWR Reduction Compliance.

When SDCWA imposes a mandatory use reduction, PSAWR customers must be prepared to reduce consumption by complying with a water allocation, or water use target. Water consumed during each billing period will be compared to the assigned target. Any use below the target will be accumulated and carried forward. The customer's cumulative use will be compared with the cumulative target, and any total usage above the target will be billed at the "above average" rates. This cumulative comparison will continue for the duration of the fiscal year. Below target usage "credits" will be carried forward until the cumulative target is exceeded, at which time, all cumulative "over target" use will be billed at the "above target" rates. The cumulative comparison process will start over in the next fiscal year.

Upon written request, customers shall reserve the right to "group" accounts and adjust, or "smooth", allocations to facilitate compliance.

Sec. 17.2                    Findings.

The Board of Directors finds and determines that a water shortage could exist as a result of a general regional water supply shortage due to increased demand or limited supplies.

The Board of Directors also finds and determines that the conditions prevailing in the coastal San Diego County area require that the water resources available be put to maximum beneficial use to the extent to which they are capable, and that the waste or unreasonable use, or unreasonable method of use, of water be prevented and that the conservation of such water encouraged with a view to the maximum reasonable and beneficial use thereof in the interests of the people of the Fallbrook Public Utility District and for the public welfare.

NORMAL CONDITIONS. The District's service area is in a semi-arid climate. Good water management practices dictate that water be used wisely and not wasted at any time. Customers are requested to follow the guidelines presented in Sec. 17.8.1. Under Normal Conditions, the District will provide public education and outreach efforts to emphasize public awareness of the need to always voluntarily use water wisely and practice water conservation measures.

Sec. 17.3                    Application.

The provisions of this Administrative Code shall apply to all water served to persons, customers, and property by the Fallbrook Public Utility District.

Sec. 17.4                    Determination and Declaration by General Manager of Water Supply Conditions.

Based on information provided by the District's wholesale water agency of water availability supplies, the Fallbrook Public Utility District General Manager (or in the General Manager's absence his designee) is hereby authorized and directed to implement the provisions of this Administrative Code. Additionally, the General Manager (or in the General Manager's absence, his designee) is hereby authorized to make minor and limited exceptions to prevent undue hardship or unreasonable restrictions, provided that water shall not be wasted or used unreasonably and the purpose of this Administrative Code can be accomplished. Any such exceptions shall be reported to the Board of Directors at the next meeting.

The General Manager (or in the General Manager's absence his designee) shall from time to time based upon all available data determine and declare whether the District's water supply is in the following condition and post a notice thereof in the District's lobby and publish said notice in the local newspaper:

WATER SHORTAGE RESPONSE LEVEL 1 – WATER SHORTAGE WATCH CONDITION. This level applies when the San Diego County Water Authority notifies its member agencies that due to water shortage or other supply reductions, there is a reasonable probability there will be supply shortages and that a consumer demand reduction of up to 10 percent is required in order to ensure that sufficient supplies will be available to meet anticipated demands. The General Manager shall declare the existence of a Water Shortage Response Level 1 condition and take action to implement the Level 1 conservation practices identified in Sec. 17.8.2. The District will suspend consideration of annexations to its service area.

The Board of Directors shall from time to time based upon all available data determine and declare whether the District's water supply is in one of the following conditions and post a notice thereof in the District's lobby and publish said notice in the local newspaper:

WATER SHORTAGE RESPONSE LEVEL 2 – WATER SHORTAGE ALERT CONDITION. This level applies when the San Diego County Water Authority notifies its member agencies that due to cutbacks caused by water shortages or other reduction in supplies, a consumer demand reduction of up to 20 percent is required in order to have sufficient supplies available to meet anticipated demands. The Board of Directors shall declare the existence of a Water Shortage Response Level 2 condition and implement the mandatory Level 2 conservation measures identified in Sec. 17.8.3. The District will suspend consideration of annexations to its service.

WATER SHORTAGE RESPONSE LEVEL 3 – WATER SHORTAGE CRITICAL CONDITION. This level applies when the San Diego County Water Authority notifies its member agencies that due to increasing cutbacks caused by water shortages or other reduction of supplies, a consumer demand reduction of up to 40 percent is required in order to have sufficient supplies available to meet anticipated demands. The Board of Directors shall declare the existence of a Water Shortage Response Level 3 condition and implement the Level 3 conservation measures identified in Sec. 17.8.4. The District will suspend consideration of annexations to its service area and no new potable water service shall be provided and no statements of immediate ability to serve or provide potable water service shall be issued.

WATER SHORTAGE RESPONSE LEVEL 4 – DROUGHT EMERGENCY CONDITION. This level applies when the San Diego County Water Authority Board of Directors declares a water shortage emergency pursuant to California Water Code Section 350 and notifies its member agencies that Level 4 requires a demand reduction of more than 40% in order for the District to have maximum supplies available to meet anticipated demands. The District shall declare a Water Shortage Emergency in the manner and on the grounds provided in California Water Code Section 350.

The General Manager is authorized to require submission of water use curtailment plans from those users having the largest effect on overall District consumption in order to protect the minimum supplies necessary to provide for public health, sanitation, and fire protection. Failure to provide curtailment plans in a timely manner or plans that do not meet the required cutbacks shall authorize the District to install flow restrictors at the meter or termination of service.

Sec. 17.5 Implementation of Emergency Water Management Program.

California Water Code Sections 375 et seq. permit public entities which supply water at retail to adopt and enforce a water conservation program to reduce the quantity of water used by the people therein for the purpose of conserving the water supplies of such public entity.

At such time when the Board of Directors of the District finds and determines that by reason of an anticipated general water supply shortage, inadequate San Diego County Water Authority distribution facilities, or the prospect of a major failure of the supply and distribution facilities of the Metropolitan Water District of Southern California exists, the Board may adopt and enforce a water conservation program to reduce the quantity of water used by the people therein for the purpose of conserving the water supplies of such public entity. Upon adoption of a water conservation program, the district shall provide notice to customers within (14) days of the Board's declaration of a water shortage. In addition, the Board may also find and determine that the conditions prevailing in the coastal San Diego county area require that the water resources available be put to maximum beneficial use to the extent to which they are capable, and that the waste or unreasonable use, or unreasonable method of use, of water be prevented and that the conservation of such water encouraged with a view to the maximum reasonable and beneficial use thereof in the interests of the people within the Fallbrook Public Utility District service area and for the public welfare.

The General Manager shall determine the extent of the emergency conservation required in order for the District to prudently plan for and supply water to its customers. Thereafter, the General Manager may order that the Emergency Water Management Program be implemented or terminated in accordance with the applicable provisions of this Article of the Administrative Code. The declaration of a water emergency shall be made by public

announcement and notice shall be published a minimum of three (3) consecutive times in a newspaper of general circulation and shall become effective immediately upon announcement.

The declaration shall be reported to the Board of Directors at its next regular meeting. The Board of Directors shall thereupon ratify the declaration or rescind the declaration, and may adopt such additional rules and regulations to limit water use during the emergency as it deems appropriate.

Sec. 17.6                    Duration of Declaration.

As soon as a particular condition is declared to exist, the water conservation measures provided for herein for that condition shall apply to all District water service until a different condition is declared.

Sec. 17.7                    Mandatory and Discretionary Use of Recycled Water.

Nothing in this Administrative Code shall prohibit or limit the use of recycled water for any purposes listed herein. No customer of the District shall make, cause, use or permit the use of potable water supplied by the District for construction grading on major subdivisions, paved surface cleaning, or greenbelt uses, including, but not limited to, cemeteries, playing fields, parks, and highway landscaped areas, when, following notice and a hearing, the District finds that recycled water is available under the following conditions:

1.     The recycled water is of adequate quality and is available for use.
2.     The recycled water may be furnished to such areas at a reasonable cost, equal to or less than the cost of supplying potable domestic water.
3.     The State Department of Health Services has determined that such use would not be detrimental to public health.
4.     The use of recycled water will not adversely affect downstream water rights, and will not degrade water quality.

Sec. 17.8                    Water Conservation Stages.

Sec. 17.8.1                NORMAL CONDITIONS.

During Normal Conditions, customers are asked to use water wisely and to practice water conservation measures so that water is not wasted.

No water furnished by the District will be wasted. All water withdrawn from District facilities shall be put to reasonable beneficial use. District water users shall comply with the following water use prohibitions and conservation measures at all times:

1.     Do not wash down paved surfaces, including but not limited to sidewalks, driveways, parking lots, tennis courts, or patios, except when it is necessary to alleviate safety or sanitation hazards.

2. Eliminate water waste resulting from inefficient landscape irrigation, such as runoff, low head drainage, or overspray, etc. Similarly, stop water flows onto non-targeted areas, such as adjacent property, non-irrigated areas, hardscapes, roadways, or structures.
3. Irrigate residential and commercial landscape before 10 a.m. and after 6 p.m. only.
4. Use a hand-held hose equipped with a positive shut-off nozzle or bucket to water landscaped areas, including trees and shrubs located on residential and commercial properties that are not irrigated by a landscape irrigation system.
5. Irrigate nursery and commercial grower's products before 10 a.m. and after 6 p.m. only. Watering is permitted at any time with a hand-held hose equipped with a positive shut-off nozzle, a bucket, or when a drip/micro-irrigation system/equipment is used. Irrigation of nursery propagation beds is permitted at any time. Watering of livestock is permitted at any time.
6. Use re-circulated water to operate ornamental fountains.
7. Wash vehicles using a bucket and a hand-held hose with positive shut-off nozzle, mobile high pressure/low volume wash system, or at a commercial site that re-circulates (reclaims) water on-site. Avoid washing during hot conditions when additional water is required due to evaporation.
8. The irrigation with potable water of ornamental turf on public street medians is prohibited.
9. The application of potable water to outdoor landscapes during or within 48 hours of measurable rainfall is prohibited
10. The irrigation with potable water of landscapes outside of newly constructed homes and buildings in a manner inconsistent with regulations or other requirements established by the County of San Diego's Landscape Ordinance.
11. Serve and refill water in restaurants and other food service establishments only upon request.
12. Offer guests in hotels, motels, and other commercial lodging establishments the option of not laundering towels and linens daily.
13. Repair all water leaks within five (5) days of notification by the Fallbrook Public Utility District unless other arrangements are made with the General Manager.
14. Use recycled or non-potable water for construction purposes when available.

Sec. 17.8.2 WATER SHORTAGE RESPONSE LEVEL 1 – WATER SHORTAGE WATCH CONDITION.

During a Level 1 Water Shortage Watch condition, the District will increase its public education and outreach efforts to emphasize increased public awareness of the need to implement water conservation practices.

All persons using District water shall comply with Normal Conditions water conservation practices during a Level 1 Water Shortage Watch, as identified in Sec. 17.8.1.

Upon declaration of a Level 1 Water Shortage Watch condition, the District will suspend consideration of annexations to its service area except under the following circumstances:

1. The applicant provides substantial evidence of an enforceable commitment that water demands for the project will be offset prior to the provision of a new water meter(s) to the satisfaction of Fallbrook Public Utility District.

Sec. 17.8.3 WATER SHORTAGE RESPONSE LEVEL 2 – WATER SHORTAGE ALERT CONDITION.

During a Level 2 Water Shortage Alert condition, all persons using District water shall comply with Normal and Level 1 Water Shortage Watch water conservation practices during a Level 2 Water Shortage Alert, as identified in Sec. 17.8.1 and 17.8.2, and shall also comply with the following additional conservation measures:

1. During the months of June through October, limit residential and commercial landscape irrigation to no more than two (2) days per week on a schedule established by the General Manager and posted by the Fallbrook Public Utility District. During the months of November through May, landscape irrigation is limited to no more than once per week on a schedule established by the General Manager and posted by the Fallbrook Public Utility District. During extreme Santa Ana conditions (temperature > 80 and easterly winds > 20 mph), one additional day per week of watering is allowed. This section shall not apply to commercial growers or nurseries. This provision does not apply to landscape irrigation systems using water efficient devices, including but not limited to: weather based controllers, drip/micro-irrigation systems and stream rotor sprinklers.
2. Limit lawn watering and landscape irrigation using sprinklers to no more than ten (10) minutes per watering station per assigned day. This provision does not apply to landscape irrigation systems using water efficient devices, including but not limited to: weather based controllers, drip/micro-irrigation systems and stream rotor sprinklers.
3. Water landscaped areas, including trees and shrubs located on residential and commercial properties, and not irrigated by a landscape irrigation system governed by section 5 (b) (1), on the same schedule set forth in section 5 (b) (1) by using a bucket, hand-held hose with a positive shut-off nozzle, or low-volume non-spray irrigation.



4. Repair all leaks within seventy-two (72) hours of notification by the Fallbrook Public Utility District unless other arrangements are made with the General Manager.

For Levels 2 and above, the District may establish a water allocation for property served by the Fallbrook Public Utility District using a method that does not penalize persons for the implementation of conservation methods or the installation of water saving devices and allows for the banking and subsequent use of unused allocations.

If the District establishes a water allocation it shall provide notice of the allocation within (14) days of its establishment by including it in the regular billing statement for the fee or charge or by any other mailing to the address to which the District customarily mails the billing statement for fees or charges for ongoing water service. The following customer classes are subject to allocations: Commercial Agriculture (CA), Commercial Agriculture Domestic (CB), Commercial (C), Government (G), and Irrigation (I). Following the effective date of the water allocation as established by the District, any person that uses water in excess of the allocation shall be subject to a penalty in the amount of 1.5 times the Base Rate, for each unit of usage greater than the allocation. The penalty for excess water usage shall be cumulative to any other remedy or penalty that may be imposed for violation of this ordinance.

This provision shall not be construed to preclude the resetting or turn-on of meters to provide continuation of water service or to restore service that has been interrupted for a period of one year or less.

Sec. 17.8.4 WATER SHORTAGE RESPONSE LEVEL 3 – WATER SHORTAGE CRITICAL CONDITION.

During a Level 3 Water Shortage Critical condition, all persons using District water shall comply with Normal, Level 1 Water Shortage Watch and Level 2 Water Shortage Alert water conservation practices during a Level 3 Water Shortage Critical condition and shall also comply with the following additional mandatory conservation measures:

1. During the months of June through October, limit residential and commercial landscape irrigation to no more than two (2) assigned days per week on a schedule established by the General Manager and posted by the Fallbrook Public Utility District. This section shall not apply to commercial growers or nurseries.
2. Water landscaped areas, including trees and shrubs located on residential and commercial properties, and not irrigated by a landscape irrigation system governed by section 6 (b) (1), on the same schedule set forth in section 6 (b) (1) by using a bucket, hand-held hose with a positive shut-off nozzle, or low-volume non-spray irrigation.
3. Stop filling or re-filling ornamental lakes or ponds, except to the extent needed to sustain aquatic life, provided that such animals are of significant value and have

been actively managed within the water feature prior to declaration of a drought response level under this ordinance.

4. Stop washing vehicles except at commercial carwashes that recirculate water, or by high pressure/low volume wash systems.
5. Repair all leaks within forty-eight (48) hours of notification by the Fallbrook Public Utility District unless other arrangements are made with the General Manager.

Sec. 17.8.5 WATER SHORTAGE RESPONSE LEVEL 4 – WATER SHORTAGE EMERGENCY CONDITION.

During a Level 4 Water Shortage Emergency condition, all persons using District water shall comply with Normal, Level 1 Water Shortage Watch, Level 2 Water Shortage Alert, and Level 3 Water Shortage Critical water conservation practices during a Level 4 Water Shortage Emergency and shall also comply with the following additional mandatory conservation measures:

1. Stop all landscape irrigation, except crops and landscape products of commercial growers and nurseries. This restriction shall not apply to the following categories of use unless the Fallbrook Public Utility District has determined that recycled water is available and may be lawfully applied to the use.
  - A. Maintenance of trees and shrubs that are watered on the same schedule set forth in section 6 (b) (1) by using a bucket, hand-held hose with a positive shut-off nozzle, or low-volume non-spray irrigation;
  - B. Maintenance of existing landscaping necessary for fire protection as specified by the Fire Marshal of the local fire protection Fallbrook Public Utility District having jurisdiction over the property to be irrigated;
  - C. Maintenance of existing landscaping for erosion control;
  - D. Maintenance of plant materials identified to be rare or essential to the well being of rare animals;
  - E. Maintenance of landscaping within active public parks and playing fields, day care centers, school grounds, cemeteries, and golf course greens, provided that such irrigation does not exceed two (2) days per week according to the schedule established under section 6 (b) (1);
  - F. Watering of livestock; and
  - G. Public works projects and actively irrigated environmental mitigation projects.

2. Repair all water leaks within twenty-four (24) hours of notification by the Fallbrook Public Utility District unless other arrangements are made with the General Manager.

The District may establish a water allocation for property served by the District. If the District establishes a water allocation it shall provide notice of the allocation by including it in the regular billing statement for the fee or charge or by any other mailing to the address to which the District customarily mails the billing statement for fees or charges for ongoing water service. Following the effective date of the water allocation as established by the District, any person that uses water in excess of the allocation shall be subject to a penalty in the amount 1.5 times the Base Rate, for each unit of usage greater than the allocation. The penalty for excess water usage shall be cumulative to any other remedy or penalty that may be imposed for violation of this ordinance.

3. (PSAWR) customers as defined in the San Diego County Water Authority (SDCWA) Administrative Code must abide by any PSAWR restrictions that may be in place.

Water consumed during each billing period will be compared to the assigned target. Any use below the target will be accumulated and carried forward. The customer's cumulative use will be compared with the cumulative target, and any total usage above the target will be billed at the "above target" rates. This cumulative comparison will continue for the duration of the fiscal year. Below target usage "credits" will be carried forward until the cumulative target is exceeded, at which time, all cumulative "over target" use will be billed at the "above target" rates and the cumulative comparison process will start over in the next fiscal year.

Sec. 17.8.6 Drought Rates

Drought Rates would be implemented during declaration of Levels 1, 2, 3 and 4 described above. Drought Rates would only be in effect during declared drought Levels 1-4. The effective January 1, 2018, the Drought Rates during drought Levels 1-4 are set forth in the tables below:

<b>2018 Monthly Drought Rates by Drought Levels (\$/kgal)</b>			
<b>Customer Class (See Article 12 for class definitions)</b>	<b>Level 1</b>	<b>Level 2</b>	<b>Level 3 and 4</b>
<b>Residential (D, LD,M)</b>			
Tier 1	\$5.91	\$6.16	\$6.92
Tier 2	\$6.00	\$6.26	\$7.03
Tier 3	\$7.30	\$7.62	\$8.56
<b>Ag. Domestic (AT)</b>			
Tier 1	\$5.91	\$6.16	\$6.92
Tier 2*	\$4.83	\$4.83	\$4.83
Tier 3*	\$4.17	\$4.17	\$4.17
<b>Commercial Domestic Ag. (CB)</b>			
Tier 1	\$5.91	\$6.16	\$6.92

Tier 2	\$5.08	\$5.30	\$5.95
<b>Agriculture TSAWR (AS)*</b>	\$4.17	\$4.17	\$4.17
<b>Commercial Ag (CB)</b>	\$5.08	\$5.30	\$5.95
<b>Commercial (C)</b>	\$6.08	\$6.35	\$7.13
<b>Irrigation Only (I)</b>	\$6.07	\$6.34	\$7.12
<b>Government (G)</b>	\$5.99	\$6.25	\$7.02

\*TSAWR customers must implement cuts to water use during drought restrictions or face penalties. Program compliance is discussed above in Section 17.1.2.

Sec. 17.9 Implementation of Conservation Levels.

The General Manager shall monitor the projected supply and demand for water by its customers on a daily basis. The General Manager shall determine the extent of the conservation required through the implementation and/or termination of particular conservation stages in order for the District to prudently plan for and supply water to its customers. Thereafter, the General Manager may order or recommend to the Board of Directors that the appropriate level of water conservation be implemented or terminated in accordance with the applicable provision of this Administrative Code. The declaration of any level beyond Water Shortage Response Level 1 shall be made by public announcement and notice shall be published a minimum of three (3) consecutive times in a newspaper of general circulation. The level designated shall become effective immediately upon announcement. The declaration of any level beyond Water Shortage Response Level 1 shall be by action of the Board of Directors.

Sec. 17.10 Variances.

If, due to unique circumstances, a specific requirement of this Article of the Administrative Code would result in undue hardship to a person using District water or to property upon which the District water is used, that is disproportionate to the impacts to the District water users generally or to similar property or classes of water uses, then the person may apply for a variance to the requirements as provided in this section.

The variance may be granted or conditionally granted, only upon a written finding of the existence of facts demonstrating an undue hardship to a person using District water or to property upon which the District water is used, that is disproportionate to the impacts to the District water users generally or to similar property or classes of water use due to specific and unique circumstances of the user or the user's property.

A completed appeal shall describe the specific reason(s) the allocation is causing undue hardship, including the following:

1. Commercial buildings that were empty or partially occupied during base period but are now occupied to a greater degree and require more water.
2. A grove with new trees planted a year before the base period began that, in the third year of growth, would need additional water.
3. Agricultural land used for annual crops that had abnormally low irrigation application during the base year.

4. An unexpected emergency line break, or equipment malfunction that has since been fixed.
5. Loss or reduction of an alternative water source, such as a well or pond.
6. Other, with a detailed description.

Sec. 17.10.1 Application.

Application for a variance shall be a form prescribed by Fallbrook Public Utility District.

Sec. 17.10.2 Supporting Documentation.

The application shall be accompanied by photographs, maps, drawings, and other information, including a written statement of the applicant.

Sec. 17.10.3 Required Findings for Variance.

An application for a variance shall be denied unless the approving authority finds, based on the information provided in the application, supporting documents, or such additional information as may be requested, and on water use information for the property as shown by the records of the Fallbrook Public Utility District, all of the following:

- A. That the variance does not constitute a grant of special privilege inconsistent with the limitations upon other Fallbrook Public Utility District customers.
- B. That because of special circumstances applicable to the property or its use, the strict application of this ordinance would have a disproportionate impact on the property or use that exceeds the impacts to customers generally.
- C. That the authorizing of such variance will not be of substantial detriment to adjacent properties, and will not materially affect the ability of the Fallbrook Public Utility District to effectuate the purpose of this chapter and will not be detrimental to the public interest.
- D. That the condition or situation of the subject property or the intended use of the property for which the variance is sought is not common, recurrent or general in nature.

Sec. 17.10.4. Approval Authority.

The General Manager or his/her designee shall exercise approval authority and act upon any completed application no later than 20 days after submittal and may approve, conditionally approve, or deny the variance. The applicant requesting the

variance shall be promptly notified in writing of any action taken. Unless specified otherwise at the time a variance is approved, the variance applies to the subject property during the term of the mandatory drought response.

Sec. 17.10.5 Appeals to Fallbrook Public Utility District Board of Directors.

An applicant may appeal a decision or condition of the General Manager on a variance application to the Fallbrook Public Utility District Board of Directors within 10 days of the written decision upon written request for a hearing. The request shall state the grounds for the appeal. Any determination not appealed within ten (10) days is final. At a public meeting, the Fallbrook Public Utility District Board of Directors shall act as the approval authority and review the appeal de novo by following the regular variance procedure. The decision of the Fallbrook Public Utility District Board of Directors is final.

ARTICLE 26 (Renumbered as Article 17  
by Resolution 5006)

Sec. 26.6 – Rev. 7/97

Sec. 26.4, Sec. 26.5, Sec. 26.8.2 –  
Rev. 10/07

Article 26 revised in its entirety –  
6/08

Sec. 26.8.3, 26.9, 26.10 , 26.10.1,  
26.10.2, 26.10.3, 26.10.4, 26.10.5,  
and addition of Domestic Class and  
Multi-Unit Class rates– Rev. 6/09

Sec. 26.8.3 –Rev. 10/09

Sec. 26.8.3 – Rev. 5/11

Sec. 26.8.3 – Rev. 8/14

Sec. 26.11 – Rev 6/15

Secs. 26.1.1, 26.1.2, 26.4, 26.5,  
26.8.3, 26.8.5, 26.10, 26.10.1,  
26.10.4, 26.10.5, 26.11 – Rev. 3/16

Secs. 26.8.1, 26.8.3 – Rev. 6/16

Secs. 26.8.2, 26.8.3, 26.8.6 – Rev.  
12/17

Secs. 26.1.1, 26.1.2, 26.8.5 – Rev.  
12/20

## **Article 18. Investment Policy**

### **Sec. 18.1 General.**

The District's Investment Policy and practices of the District Treasurer are based on prudent money management principles and California Government Code, specifically Sections 53600 and 53630 et. seq.

18.1.1 **Delegation of Authority.** The Board of Directors delegates the investment authority of the District to the Treasurer under the supervision of the General Manager. The Treasurer shall deposit money under the Treasurer's supervision and control in such institutions and upon such terms as the laws of the State of California and the Board of Directors may permit.

The Treasurer may delegate day-to-day investment decision making and execution authority to an investment advisor. Eligible investment advisors must be registered with the Securities and Exchange Commission (SEC) under the Investment Advisors Act of 1940. The advisor will follow the Policy and such other written instructions as are provided by the District.

18.1.2 **Investment Objectives.** The practices of this District will always comply with the legal authority and limitations placed on it by the governing legislative bodies. The implementation of these laws, allowing for the dynamics of the money markets, will be the focus of this Investment Policy. When investing, reinvesting, purchasing, acquiring, exchanging, selling and managing public funds, the objectives of this District shall be:

1. The primary objective shall be to safeguard the principal of the funds under the Treasurer's control.
2. The secondary objective shall be to meet the liquidity needs of the District.
3. The third objective shall be to achieve a return on the funds under control of the Treasurer within the parameters of prudent risk management.

18.1.3 **Prudent Investor Standard.** The Board of Directors, General Manager, and Treasurer adhere to the guidance provided by the "prudent investor standard," California Government Code (Section 53600.3), which obligates a fiduciary to insure that "When investing, reinvesting, purchasing, acquiring, exchanging, selling, or managing public funds, a trustee shall act with care, skill, prudence, and diligence under the circumstances then prevailing, including, but not limited to, the general economic conditions and the anticipated needs of the agency, that a prudent person acting in a like capacity and familiarity with those matters would use in the conduct of funds of a like character and with like aims, to safeguard the principal and maintain the liquidity needs of the agency. Within the limitations of this section and considering individual investments as part of an overall strategy, investments may be acquired as authorized by law."

Sec. 18.2      Treasurer's Annual Statement of Investment Policy.

The following is the District's annual statement of investment policy rendered pursuant to Section 53646 (a) of the Government Code:

18.2.1            Security of Principal Policy. The policy issues directed to protecting the District are:

- a) Limiting exposure to each type of security.
- b) Limiting exposure to each issue and issuer of debt.
- c) Determining the minimum credit requirement for each type of security at the time of purchase.

18.2.2            Liquidity Policy. The policy issues directed to provide necessary liquidity are:

- a) Limiting the length of maturity for securities in the portfolio.
- b) Limiting exposure to illiquid securities.

18.2.3            Return Policy. The policy issues directed to achieving a return are:

- a) Attaining a market rate of return taking into account the investment risk constraints and liquidity needs.
- b) Return is of least importance compared to the safety and liquidity policies described above.
- c) Majority of the investments shall be limited to low risk securities in anticipation of earning a fair return relative to the risk being taken.
- d) The performance of the portfolio shall be compared to an industry benchmark established by the Fiscal Policy and Insurance Committee and shall be reported quarterly. The Fiscal Policy and Insurance Committee shall review the performance benchmark on an annual basis to ensure that it remains appropriate for the District's investment objectives. The Fiscal Policy and Insurance Committee will bring any recommended changes to the industry benchmark to the Board for approval.

18.2.4            Maturity Policy. The maximum maturity allowed by the California Government Code is five (5) years with shorter limitations specified for specific types of securities. However, the legislative body may grant express authority to make investments either specifically or as a part of an investment program approved by the legislative body that exceeds this five-year maturity limit. Such approval must be issued no less than three (3) months prior to the purchase of any security exceeding the five-year maturity limit.

18.2.5            Prohibited Securities. The California Government Code does not authorize a local agency to invest in any of the following derivative notes:



- a) Inverse Floater
- b) Range Notes
- c) Interest-only strips derived from a pool of mortgages
- d) Any security that could result in zero interest accrual

Sec. 18.3      Internal Controls.

The Treasurer is responsible for establishing and maintaining an internal control structure designed to ensure that the assets of the District are protected from loss, theft or misuse. The internal control structure shall be designed to provide reasonable assurance that these objectives are met. The concept of reasonable assurance recognizes that: 1) the cost of a control should not exceed benefits likely to be derived; and, 2) the valuation of costs and benefits requires estimates and judgments by management. Accordingly, the Treasurer shall establish a process for annual independent review by an external auditor to assure compliance with policies and procedures. The internal controls shall address the following points:

Control of Collusion: Collusion is a situation where two or more employees are working in conjunction to defraud their employer.

Separation of Transaction Authority from Accounting and Record Keeping: By separating the person who authorizes or performs the transaction from the person who records or otherwise accounts for the transaction, a separation of duties is achieved.

Custodial Safekeeping: Securities purchased from any bank or dealer including appropriate collateral (as defined by Government Code) shall be placed with an independent third party for custodial safekeeping.

Avoidance of Physical Delivery Securities: Book entry securities are much easier to transfer and account for since actual delivery of a document never takes place. Delivered securities must be properly safeguarded against loss or destruction. The potential for fraud and loss increases with physically delivered securities.

Clear Delegation of Authority to Subordinate Staff Members: Subordinate staff members must have a clear understanding of their authority and responsibilities to avoid improper actions. Clear delegation of authority also preserves the internal control structure that is contingent on the various staff positions and their respective responsibilities.

Written Confirmation of Telephone Transactions for Investments and/or Wire Transfers: Due to the potential for error and improprieties arising from telephone transactions, all telephone transactions should be supported by written communications and approved by the appropriate person. Written communications may be via fax if on letterhead and the safekeeping institution has a list of authorized signatures.

Development of a Wire Transfer Agreement with the Lead Bank or Third Party Custodian: This agreement should outline the various controls, security provisions, and delineate responsibilities of each party making and receiving wire transfers.

Sec. 18.4 Permissible Investments.

Where this Policy specifies a percentage limitation for a particular security type, that percentage is applicable only on the date of purchase. Credit criteria listed in this Policy refers to the credit rating at the time the security is purchased. If an investment advisor is used and an investment's credit rating falls below the minimum rating required at the time of purchase, the investment advisor will immediately notify the Treasurer. The securities shall be reviewed and a plan of action shall be recommended by the Treasurer or investment advisor. The course of action to be followed will be decided on a case-by-case basis, considering such factors as the reason for the rate drop, prognosis for recovery or further drop, and market price of the security. The Fiscal Policy and Insurance Committee will be advised of the situation and intended course of action by e-mail or fax.

The District will limit investments in any one non-government issuer, except investment pools and money market funds, to no more than 5% regardless of security type.

Government Code 53601 addresses permissible investments. These investment categories are:

18.4.1 Government Obligations. Two categories of Government Obligations, U.S. Treasury and Agency obligations may be invested. Both are issued at the federal level. U.S. Treasury obligations are United States Treasury notes, bonds, bills, or certificates of indebtedness, or those for which the faith and credit of the United States are pledged for the payment of principal and interest. Agency obligations are federal agency or United States government-sponsored enterprise obligations, participations, or other instruments, including those issued by or fully guaranteed as to principal and interest by federal agencies or United States government-sponsored enterprises..

Maximum Maturity: The maximum maturity of an issue shall be the current 5 year issue or an issue which at the time of the investment has a term remaining to maturity not in excess of five (5) years.

Maximum Exposure of Portfolio: The maximum exposure to the portfolio for this category is unlimited.

- 1) Treasury: Unlimited.
- 2) Agencies: Unlimited. No more than 75% of the portfolio value shall be invested in any single issuer.

Minimum Credit Requirement: None.

18.4.2 Banker's Acceptance. This is a draft or bill of exchange, accepted by a bank or trust company and brokered to investors in a secondary market. The purpose of the banker's acceptance (BA) is to facilitate trade and provide liquidity to the import-export markets. Acceptances are collateralized by the pledge of documents such as invoices, trust receipts, and other documents evidencing ownership and insurance of the goods financed.

Maximum Maturity: The maximum maturity of an issue shall be 180 days.

Maximum Exposure of Portfolio: The maximum exposure to the portfolio for this category shall be 25%.

Minimum Credit Requirement: "A-1" or equivalent by a nationally recognized statistical rating organization (NRSRO)

18.4.3 Commercial Paper. These are short-term, unsecured, promissory notes issued by firms in the open market. Commercial paper (CP) is generally backed by a bank credit facility, guarantee/bond of indemnity, or some other support agreement. The entity that issues the commercial paper must meet all of the following conditions in either paragraph a or paragraph b:

- a. The entity meets the following criteria: (i) is organized and operating in the United States as a general corporation, (ii) has total assets in excess of five hundred million dollars (\$500,000,000), and (iii) has debt other than commercial paper, if any, that is rated in a rating category of "A", the equivalent or higher by a NRSRO.
- b. The entity meets the following criteria: (i) is organized within the United States as a special purpose corporation, trust, or limited liability company, (ii) has program-wide credit enhancements including, but not limited to, over collateralization, letters of credit, or surety bond, and (iii) has commercial paper that is rated "A-1" or higher, or the equivalent, by a NRSRO.

Maximum Maturity: The maximum maturity of an issue shall be 270 days.

Maximum Exposure of Portfolio: The maximum exposure to the portfolio for this category shall be 25%. The District may purchase no more than 10% of the outstanding commercial paper of any single issuer.

Minimum Credit Requirements: "A-1", the equivalent or higher by a NRSRO.

18.4.4 Medium-Term Notes. Corporate and depository institution debt securities issued by corporations organized and operating within the United States, or by depository institutions licensed by the U.S. (or any state) and operating within the U.S.

Maximum Maturity: The maximum maturity of an issue shall be 5 years.

Maximum Exposure of Portfolio: The maximum exposure to the portfolio for this category shall be 30%.

Minimum Credit Requirements: Rated in a rating category of “A”, the equivalent or higher by a NRSRO

18.4.5 Repurchase Agreements. A repurchase agreement (RP) consists of two simultaneous transactions. One is the purchase of securities by an investor (i.e., the District), the other is the commitment by the seller (i.e., a broker/dealer) to repurchase the securities at the same price, plus interest, at some mutually agreed future date.

Maximum Maturity: The maximum maturity of repurchase agreements shall be up to one year.

Maximum Exposure of Portfolio: The maximum exposure to the portfolio for this category shall be 10%.

Minimum Credit Requirements: None

18.4.6 Negotiable Certificates of Deposit. Certificates of deposit must be issued by a nationally or state-chartered bank, a savings association or a federal association (as defined by Section 5102 of the Financial code), a state or federal credit union, or by a federally licensed or state-licensed branch of a foreign bank.

Maximum Maturity: The maximum maturity of an issue shall be five (5) years.

Maximum Exposure to Portfolio: The maximum exposure to the portfolio for this category shall be 30%.

Minimum Credit Requirements: Rated in a rating category of “A”, the equivalent or higher for CDs issued with a long-term rating and “A-1” or higher for CDs issued with a short-term rating or their equivalents by a NRSRO.

18.4.7 State Local Agency Investment Fund (LAIF). There is no limit by law on the amount of funds that can be placed in this account. Interest is paid directly into the account by the State Local Agency Investment Fund.

18.4.8 San Diego County Treasurer’s Fund. There is no limit by law on the amount of funds that can be placed in this account. Interest is paid directly into the account by the County Treasurer.

18.4.9 Passbook and Money Market Savings Accounts. Savings accounts and/or money market accounts shall be maintained for monies that are needed on a day-to-day basis.

18.4.10 State Obligations / State of California and Other States. Registered state warrants or treasury notes or bonds of this state, including bonds payable solely out of the revenues from a revenue-producing property owned, controlled or operated by the state or by a department, board, agency or authority of the state.

Registered treasury notes or bonds of any of the other 49 United States in addition to California, including bonds payable solely out of the revenues from a revenue-producing property owned, controlled, or operated by a state or by a department, board, agency, or authority of any of the other 49 United States, in addition to California.

Maximum Maturity: The maximum maturity of an issue shall be the current 5 year issue or an issue which at the time of the investment has a term remaining to maturity not in excess of five (5) years.

Maximum Exposure of Portfolio: The maximum exposure to the portfolio for 18.4.10 and 18.4.11-California Local Agency Obligations, category shall be a combined 25% of the book value of the investment portfolio. No more than 5% of the book value of the portfolio at the time of purchase may be invested in bonds issued by any one agency.

Minimum Credit Requirements: Rated in a rating category of “A”, the equivalent or higher for obligations issued with a long-term rating and “A-1” for obligations issued with a short-term rating or their equivalents by a NRSRO .

18.4.11 California Local Agency Obligations. Bonds, notes warrants or other evidences of indebtedness of any local agency within California, including bonds payable solely out of the revenues from a revenue-producing property owned, controlled, or operated by the local agency, or by a department, board, agency, or authority of the local agency.

Maximum Maturity: The maximum maturity of an issue shall be the current 5 year issue or an issue which at the time of the investment has a term remaining to maturity not in excess of five (5) years.

Maximum Exposure of Portfolio: The maximum exposure to the portfolio for 18.4.10 and 18.4.11-California Local Agency Obligations, category shall be a combined 25% of the book value of the investment portfolio. No more than 5% of the book value of the portfolio at the time of purchase may be invested in bonds issued by any one agency.

Minimum Credit Requirements: Rated in a rating category of “A”, the equivalent or higher for obligations issued with a long-term rating and “A-1” for obligations issued with a short-term rating or their equivalents by a NRSRO.

18.4.12 Joint Powers Authority Pool. The investment with a Joint Powers Authority Pool is mandated by that pool. To be eligible under this section, the joint powers authority issuing the shares shall have retained an investment adviser that meets all of the following criteria: (1) The adviser is registered or exempt from registration with the

Securities and Exchange Commission; (2) The adviser has not less than five years of experience investing in the securities and obligations authorized in subdivisions (a) to (q), inclusive; and (3) The adviser has assets under management in excess of five hundred million dollars (\$500,000,000).

Maximum Exposure of Portfolio: The maximum exposure to the portfolio for this category is unlimited.

Minimum Credit Requirement: None.

#### 18.4.13 Money Market Mutual Funds.

Maximum Exposure of Portfolio: The maximum exposure to the portfolio for this category is 20%.

Minimum Credit Requirements: A mutual fund must receive the highest ranking by not less than two nationally recognized rating agencies or the fund must retain an investment advisor who is registered with the SEC (or exempt from registration), has assets under management in excess of \$500 million, and has at least five years experience investing in instruments authorized by Sections 53601 and 53635.

A money market mutual fund must receive the highest ranking by not less than two nationally recognized statistical rating organizations or retain an investment advisor registered with the SEC or exempt from registration and who has not less than five years experience investing in money market instruments with assets under management in excess of \$500 million.

18.4.14 Mortgage Pass-Through Securities and Asset-Backed Securities. A mortgage pass-through security, collateralized mortgage obligation, mortgage-backed or other pay-through bond, equipment lease-backed certificate, consumer receivable passthrough certificate, or consumer receivable-backed bond.

Maximum Maturity: The maximum maturity of an issue shall be the current 5 year issue or an issue which at the time of the investment has a term remaining to maturity not in excess of five (5) years.

Maximum Exposure of Portfolio: The maximum exposure to the portfolio for this category is 20%.

Minimum Credit Requirements: Rated in a rating category of “AA”, the equivalent or higher by a NRSRO.

18.4.15 Supranationals. United States dollar denominated senior unsecured unsubordinated obligations issued or unconditionally guaranteed by the International Bank for Reconstruction and Development, International Finance Corporation, or Inter-American Development Bank.

Maximum Maturity: The maximum maturity of an issue shall be the current 5 year issue or an issue which at the time of the investment has a term remaining to maturity not in excess of five (5) years.

Maximum Exposure of Portfolio: The maximum exposure to the portfolio for this category is 30%.

Minimum Credit Requirements: Rated in a rating category of “AA”, the equivalent or higher by a NRSRO.

Approval: Investments in supranational securities may only be made with prior approval of the Fiscal Policy and Insurance Committee.

Sec. 18.5      Maturity/Limit of Investments.

With the exception of U.S. Treasury and Federal Agency securities, the maturity of a give investment will not exceed five (5) years, without prior board approval per Section 18.2.4.

Sec. 18.6      Reporting Requirements.

The Treasurer shall prepare a quarterly investment report to the Board of Directors that provides an overview of the District’s investments and lists the investment transactions for the period. The report shall also (1) state the compliance of the portfolio with the statement of investment policy, or the manner in which the portfolio is not in compliance, and (2) the report shall include a statement denoting the ability of the District to meet its expenditure requirements for the next six months, or provide an explanation as to why sufficient money shall, or may, not be available. The Treasurer shall also provide the Board a summary report of investments on a monthly basis.

A subsidiary ledger of investments may be used in the report in accordance with accepted accounting practices.

In the event that an investment originally purchased within policy guidelines is downgraded by any one of the credit rating agencies, the Treasurer shall report it at the next regular scheduled meeting of the Board.

**ARTICLE 27 (Renumbered as Article 18 by Resolution 5006)**

Revised in its entirety: 2/94

Adopted in current form: 1/96,  
1/97, 1/98, 1/99

Sec. 27.2.4 – Rev. 1/00

Adopted in current form: 1/01

Sec. 27.4.7 – Rev. 10/01

Sec. 27.6 – Rev. 1/03

Sec. 27.2.4 – Rev. 1/07

Sec. 27.4.4 – Rev. 3/07

Secs. 27.2.3, 27.4.1(2), 27.4.2,  
27.4.3, 27.4.4, & 27.4.6 – Rev. 9/07

Sec. 27.2.1 – Rev. 1/10

Secs. 27.4.10-12 – Rev. 1/12

Secs. 27.2.4, 27.2.5, 27.4.5, 27.4.6,  
27.4.7, 27.4.10, 27.4.11, 27.4.13,  
27.4.14, 27.5 – Rev. 2/13

Secs. 27.4.6, 27.4.11 – Rev. 1/14

Secs. 27.1, 27.1.1, Attachment A –  
Rev. 3/15

Secs. 27.1, 27.1.1, 27.1.2, 27.1.3,  
27.2, 27.2.3, 27.2.4, 27.3, 27.4,  
27.4.1, 27.4.2, 27.4.3, 27.4.4,  
27.4.6, 27.4.10, 27.4.11, 27.4.12,  
27.4.13, 27.4.14, 27.4.15, 27.5 –  
Rev. 2/16

Secs. 27.2.4, 27.4, 27.4.3, 27.4.4,  
27.4.6, 27.4.10, 27.4.11, 27.4.14,  
27.4.15 – Rev. 3/17

Sec. 27.2.3 – Rev. 6/18

Sec. 27.6 – Rev. 7/18

Sec. 27.4.14 – Rev. 2/19



## **Article 19. Recycled Water Program**

### **Sec. 19.1 Declaration of Policy.**

- a. The Fallbrook Public Utility District (FPUD) operates and maintains a recycled water distribution system within its service area enabling it to provide disinfected tertiary treated recycled water for a variety of beneficial uses. The District shall require the use of recycled water in-lieu of potable water for irrigation or other non-potable uses where recycled water is suitable and available.
- b. The beneficial use of recycled water is regulated by the California State Water Resources Control Board (SWRCB). California Water Code Section 13551 establishes a State policy to encourage the use of recycled water.
- c. FPUD shall determine whether a potential service will be furnished with recycled water and/or potable water. The feasibility of recycled water service will be considered on a case-by-case basis and in accordance with applicable law.

### **Sec. 19.2 Statutory Requirements.**

- a. All onsite and public recycled water facilities must be consistent with and adhere to the requirements described in the following documents:
  1. FPUD Backflow and Cross-Connection Control Ordinance, Article 10.22
  2. FPUD Recycled Water Program, Article 19
  3. California Code of Regulations, Title 22, Division 4
  4. California Code of Regulations, Title 17, Division 1, Chapter 5, Subchapter 1, Group 4, Articles 1 and 2
  5. San Diego County Department of Environmental Health Recycled Water Program Requirements
  6. For Facilities Hauling Recycled Water: Engineering Report for the Installation of Hauled Recycled Water Fill Stations and Use of Hauled Recycled Water in the San Diego Region, San Diego County Water Authority, July 8, 2015
  7. All applicable Federal, State or local statutes, regulations and ordinances

### **Sec. 19.3 Approved Use.**

- a. These rules and regulations pertain to recycled water service to lands and/or improvements lying within the legal boundaries of the District unless otherwise stated. It is the intent of the District to provide recycled water service in accordance with these rules and regulations to all areas that recycled service is feasible. The District will work with existing potable water users to facilitate the conversion of existing facilities for recycled water use or the installation of facilities for a new recycled water use. All new developments will be evaluated for the feasibility of recycled water usage.

- b. The uses of recycled water include only those uses approved by the District, local and State regulatory authorities and for which Title 22, California Code of Regulations provides treatment requirements. All potential applications of recycled water shall be reviewed and approved by the District prior to installation of facilities. Prior to approval and at its discretion, the District may set forth specific requirements as conditions for providing service and/or require specific prior approval from the appropriate regulatory agencies.
- c. The facilities shall be constructed in accordance with the procedures and requirements of the District. No recycled water mains or connections to the recycled water mains shall be installed unless shown on approved drawings and approved by the District.

Sec. 19.4      Definitions.

- b. Approved Backflow Prevention Assemblies.

A device/assembly approved by the State of California and the District which is installed to protect the potable water supply from contamination through backflow of a non-potable substance.

- c. Artificial Lake.

A man-made lake, pond, lagoon, or other body of water that is used wholly or partly for landscape, scenic or non-contact recreational purposes.

- d. Board.

The duly elected and constituted Board of Directors of the Fallbrook Public Utility District.

- e. Cross-Connection.

Any unprotected actual or potential connection between any part of a water system used or intended to supply potable water and any source or system containing recycled or other water or substance that is not potable and not acceptable for human consumption.

- f. Cross-Connection Control Specialist.

An individual who has a current American Water Works Association and/or American Backflow Prevention Association Specialist Certificate on file with the District

- g. Designated User.

A recipient of recycled water service from the District.

- h. District.

The Fallbrook Public Utility District, a duly constituted Public Agency of the State of California and located in San Diego County, California.

i. Greenbelt Areas.

Greenbelt areas include, but are not limited to, golf courses, playing fields, cemeteries, parks, and landscaping.

j. Hauled Recycled Water.

Recycled water use that complies with the San Diego County Water Authority publication "Engineering Report for the Installation of Hauled Recycled Water Fill Stations and Use of Hauled Recycled Water in the San Diego Region."

k. Industrial Process Water.

Water used by any industrial facility with process water requirements which includes, but is not limited to, rinsing, washing, cooling and construction.

l. Manager.

The duly appointed General Manager of the Fallbrook Public Utility District or their designee.

m. Non-Potable Water.

Water, which does not conform to federal, state and local standards for human consumption.

n. Non-Potable Water Distribution System.

A piping system intended for the delivery of non-potable water only, and which is maintained separate from any potable water distribution system.

o. Non-Potable Water Transmission Mains.

A piping system intended for the delivery of non-potable water only and which is maintained separate from any potable water distribution system and which is owned by the District.

p. Non-Potable Water Use Area.

The property or portion of property, which has been approved by the District for non-potable or recycled water service.

q. Notice of Determination.

The notice provided to a designated user by the District.

r. Off-Site Facilities.

Those facilities located off the user's site and under the control of the District, including the service meter and any backflow prevention assembly (ies) installed with the meter.

s. On-Site Facilities.

Facilities under the control of the customer beginning at the water meter and backflow prevention assembly if installed.

t. Potable Water.

Water furnished to the customer that is approved for human consumption and conforms to all federal, state and local requirements.

u. Recycled Water.

Water which as a result of filtration and disinfection of domestic wastewater is suitable for a direct beneficial use or a controlled use that otherwise would not occur.

v. Recycled Water Facilities.

Facilities used in the storage, pumping and conveyance of recycled water.

w. Recycled Water Service Connection.

The point of connection of the customer's recycled water line with the recycled water service main of the District which shall normally be the downstream end of the recycled water meter tailpiece.

x. Site Supervisor.

An individual who has taken a training course, normally four hours in length, that has been approved by State and local authorities and the District for the on-site use of recycled water.

Sec. 19.5 Administration.

a. Manager.

The District General Manager shall administer, implement, and enforce the provisions of this Article of the Administrative Code. Any duties imposed upon the General Manager may be delegated by him to persons in the employ of the District.

b. Recycled Water Master Plan.

The General Manager shall prepare and update a Recycled Water Master Plan. The Plan shall include, but not be limited to, actual and future planning for recycled water use.

c. Coordination among Agencies.

The District shall examine the potential for initiating a coordinated effort between the District and other public agencies. The purpose of this effort shall be to share in the production and utilization of recycled water.

d. Fees and Charges.

All fees and charges for the use of recycled water shall be established separately by the Board in Article 21 of the Administrative Code.

e. Payment for On-Site Facilities.

The Designated User shall pay for all on-site facilities, including backflow prevention assemblies that may be necessary to protect the health and safety of on-site residents or employees. The Designated User of recycled water shall comply with all requirements of applicable federal, state, and local statutes, ordinances and regulations. The cost of any investigations by District staff and/or regulatory authorities resulting from the misuse of recycled water shall be the responsibility of the Designated User.

Sec. 19.6 Suspension or Termination of User Service.

19.6.1 Recycled water service may be suspended or terminated at any time by the Manager. Reasons for suspension or termination shall include, but not be limited to, the following:

1. Failure by a Designated User to adhere to the provisions of this Article.
2. The lack of necessary procedures or facilities for protection of health, safety and welfare.
3. The discovery of a cross-connection between the on-site potable and non-potable water distribution system.
4. Changes in the use and/or footprint of the non-potable distribution system without District approval.
5. Recycled water service may also be subject to discontinuation of service for failure to pay any rates, fees and charges due to the DISTRICT in accordance with the DISTRICT's discontinuation procedures then in effect for non-residential service.

19.6.2 Procedure.

The suspension or termination procedure shall be as follows: Where the District determines that service should be suspended or terminated, a written notice shall be mailed by regular mail to the customer at least ten (10) calendar days prior to the date of proposed suspension or termination of services. This notice shall set forth the reasons for the suspension or termination of services. In the event the District determines an emergency condition prevails at the time the written notice of proposed suspension or termination is mailed to the customer, the District may immediately suspend recycled water service pending a determination of any appeal. If an emergency condition does not exist, the user shall have ten (10) calendar days to come into compliance with the written notice. Thereafter the District may commence suspension or termination procedures.

19.6.3 Appeals of the Suspension or Termination Notice.

The customer may appeal the determination of the District as follows:

Not later than ten (10) calendar days following the date upon which the District Manager forwards to the customer a Notice of Suspension or Termination the customer may appeal to the Board of Directors by submitting a written appeal to the Board Secretary.

The Board of Directors shall conduct a hearing concerning the proposed determination within thirty (30) calendar days of receipt of this written appeal. Within a reasonable time thereafter the Board of Directors shall render a decision which shall be final.

#### 19.6.4 Prohibited Connections.

No person shall make any connection to the recycled water facilities of the District unless the District has executed a written Agreement with said person as Designated User of recycled water service in accordance with the provisions of the Article of the Administrative Code.

### 19.7 Implementation.

#### 19.7.1 Designation of Users.

The intent of the District is to work cooperatively with users to facilitate the conversion of existing potable users or the installation of new recycled services. The District would execute a User Agreement with the potential Designated User to implement the provisions of this Article of the Administrative Code.

If the potential Designated User declines to voluntarily execute a User Agreement with the District, but the District determines that the potential Designated User would be a beneficial user of suitable and available recycled water supplies, the District may issue a Notice of Determination that a specific water user shall be a Designated User of recycled water. A general description of the obligations of the potential Designated User shall accompany this notification. A proposed schedule for implementation of the use of recycled water shall be included in this Notice.

#### 19.7.2 Appeal.

The potential Designated User may file a Notice of Appeal with the District within thirty (30) calendar days after the Notice of Determination has been sent. Upon receipt of the Notice of Appeal the District Manager shall schedule a hearing of the appeal before the Board of Directors and provide notice in accordance with the rules of the District.

Following this hearing, the determination of the Board shall be final and binding.

#### 19.7.3 Design and Construction of On-Site Facilities.

The Designated User shall provide and install, at no cost to the District, all on-site recycled water facilities. Recycled water facilities shall conform to State and local

statutes, ordinances, regulations and District requirements. The Designated User shall make, at no cost to the District, any modifications to the potable water system on the premises which are required by the District in order to permit the safe use of recycled water service. Such facilities shall include, but not be limited to, installation of approved backflow prevention assemblies. Specifications and record drawings of on-site recycled facilities shall be prepared and be available for inspection or use on the premises of the Designated User and at the District office.

19.7.4 Recycled Water Supervisor.

The Designated User shall designate a Site Supervisor and shall keep the District informed of the Site Supervisor's identity. The Site Supervisor shall have attended a Site Supervisor training class, be knowledgeable in the construction and operation of the recycled water system and any on-site uses of recycled water. The Site Supervisor should be familiar with federal, State and local guidelines, criteria, standards, rules and regulations governing the use of recycled water. The Site Supervisor shall be responsible for overseeing the recycled water service and maintaining the on-site facilities in conformance with the District's guidelines and regulations. The Site Supervisor shall be responsible for the prevention of any cross-connections between the recycled water system and the on-site potable system. Any actual or suspected cross-connections shall immediately be reported to the District.

19.7.5 Conversion of Existing Facilities.

Where a Designated User proposes a conversion of any existing potable water system to a recycled water system, a comprehensive investigation of the system including conversion plans shall be performed at the expense of the Designated User. The District shall review and approve the conversion plans before the potable system is converted to recycled water use.

19.7.6 User Agreement Form.

Upon the final determination by the District that a property, or a portion of the property, shall be served with recycled water the Designated User shall execute a User Agreement with the District to implement the provisions of this Article of the Administrative Code. The District shall provide a general form of the agreement. The District may refuse or terminate recycled water service if a signed User Agreement is not on file with the District.

19.8 Water Meter Requirement.

All recycled water used on any premises approved for recycled water service must be metered. The District shall be responsible for the enforcement of this requirement.

When a parcel is developed, if the parcel has the potential for future recycled use or is along a planned recycled line extension, the development must provide for facilities to utilize recycled water when available or pipeline extensions through the parcel at the time of project construction.

19.9 Public Safety Requirements.

19.9.1 General Requirements.

All sites shall comply with the County of San Diego's Department of Environmental Health Recycled Water Plan Checklist and Inspection Manual and all District rules and regulations for recycled water service.

19.9.2 Backflow Protection at the Service Meter.

All recycled water sites are required to prevent backflow into the public water supply. Backflow protection will be determined by the degree of hazard present on the Designated User's property. Sites that use recycled water for irrigation purposes as part of a dual plumbed system are required to install a double check valve assembly device on the potable water service connection. Recycled water sites that also use potable water must install a reduced pressure principle backflow prevention assembly at the potable water connection.

19.10 Truck Load Delivery of Recycled Water.

The San Diego County Water Authority publication "Engineering Report for the Installation of Hauled Recycled Water Fill Stations and Use of Hauled Recycled Water in the San Diego Region" shall be complied with by any user that has been certified by the District for hauling of recycled water.

19.11 Miscellaneous.

If any section, subsection, sentence, clause or phrase of the Article of the Administrative Code is for any reason held to be unconstitutional or invalid, such decision shall not affect the validity of the remaining portions of this Article of the Administrative Code. The Board of Directors hereby declares that it would have passed each section, subsection, sentence, clause or phrase thereof irrespective of the fact that any one or more sections, subsections, or sentences, clauses or phrases may be unconstitutional or invalid.

19.12 Non-Liability.

The District will not be responsible or liable for any suspension in service of, or failure to supply, recycled water, or for any damage or injury to person or property relating to the provision of recycled water.

**ARTICLE 28 (Renumbered  
as Article 19 by Resolution  
5006)**

Program Adopted 2/94  
Sec. 28.9 – Rev. 6/95  
Sec. 28.1-28.4, 28.6, 28.9,  
28.10 – Rev. 7/97  
All Sections – Rev. 1/16  
All Sections – Rev. 1/21



**Article 20. Emergency Action Plan (EAP)**

The Fallbrook Public Utility District has adopted an Emergency Action Plan for internal use by its officers, employees and Directors. The plan sets guidelines to use when an emergency arises.

The District's Emergency Action Plan (EAP) is made a part of this Administrative Code and incorporated into the District's Injury/Illness Prevention Program (IIPP).

<p><b>ARTICLE 29</b> (Renumbered as Article 20 by Resolution 5006)</p> <hr/> <p>Program Adopted 6/94 Rev. 2/20</p>
--

## **FALLBROOK PUBLIC UTILITY DISTRICT EMERGENCY ACTION PLAN (EAP)**

All employees will follow the guidelines below when an emergency arises. All employees will be required to participate in all "training elements."

- 1) The Operations Manager (or designee) will be the individual responsible for coordinating the Emergency Response Plan. His responsibilities include, but are not limited to:
  - A. Assessing the situation to determine if an emergency exists that requires activating the District Emergency Action Plan.
  - B. Directing all efforts in the area, including evacuating personnel and minimizing property loss.
  - C. Ensuring that outside agencies are called when necessary.
  - D. Directing shutdown of operations, when necessary.
  - E. Direct the Emergency Response Team.
  
- 2) If a major emergency involving fire or threat of an explosion occurs, and evacuation of the building and/or yard is necessary, the following will be done:
  - A. The Receptionist will alert all employees by way of the intercom system that there is an emergency and that all employees will evacuate to the announced designated meeting area.
  - B. The Operations Manager will establish his "command post" next to where the employees are to be evacuated.
  - C. Alternate communications can be the District's cellular phone, radio system (high band and low band), and coordination with the Sanitary District's base station with our radio system.
  - D. Regular updating of off-duty emergency on-call personnel will help keep the answering service current on who to notify during off-hours.
  
- 3) The Operations Manager (or designee) will be responsible to account for all personnel and notify authorities if anyone is believed missing. No personnel shall leave the scene until a total head count has been conducted (unless it is not safe to remain). Do not leave this area until the Operations Manager (or designee) or your supervisor knows you are leaving.
  
- 4) The Emergency Response Team (ERT) has to be able to distinguish between an emergency that they can handle and one that needs professional emergency aid. The emergency response team will be trained in the following:
  - A. Use of various types of fire extinguishers;
  - B. First Aid and CPR;
  - C. Shutdown procedures including all electric panels, gas main and location of the shut off devices;
  - D. Evacuation procedures;
  - E. Use of breathing apparatus (when applicable);
  - F. Search and rescue procedures (if there is a major disaster).

5) The Emergency Response Team members are:

- A. Operations Manager,
- B. Field Service Manager,
- C. All Department Supervisors,
- D. Safety & Risk Officer.

6) Employee Accountability Procedures after Evacuations:

- A. When an evacuation signal is given, each supervisor involved will assume a station in the vicinity of the designated evacuation area. Supervisor will insure all personnel are evacuated and will provide assistance to employees requiring same.
- B. All employees will proceed to a designated evacuation area for a head count by their supervisor. Supervisors will then report their department's status to Safety or designee. No one is to re-enter the building or yard for any reason until the Fire Department or other responsible agency has notified the District the building or yard is safe for re-entry

---

## BUILDING EVACUATION

---

### IN THE OFFICE OR YARD:

- 1) Each employee is to be aware of all marked exits from the area and building.
- 2) When evacuating the building, do not collect your personal belongings (purse, brief case, etc.) leave by walking quickly to the nearest marked exit and ask others to do the same. **DO NOT RUN.**
- 3) Assist all customers and the handicapped in exiting the building.
- 4) When outside, proceed to the announced designated meeting area. Keep well away from the building and keep clear of emergency vehicles. Do not leave this area until the Operations Manager or your supervisor knows you are leaving.
- 5) Supervisors, to the best of their ability, and without re-entering the building, will report to the Operations Manager if everyone has evacuated the area safely.
- 6) Do not return to the building until being told it is OK to do so by the Fire Dept. or Police.

---

## FIRE

---

### IN THE OFFICE OR YARD:

- 1) Know the location of fire extinguishers in your area and know how to use them.
- 2) In case of fire, immediately call 911. Give your name and describe the location and size of the fire.
- 3) On a minor fire that appears to be controllable, promptly direct the charge of a fire extinguisher toward the base of the flame. Get help if necessary.
- 4) On large fires that are not immediately controllable, promptly or after using the extinguisher, close all doors to confine the fire and reduce the oxygen - but do not lock doors.
- 5) Notify the receptionist to alert employees and instruct them to evacuate the building by quickly walking to the nearest exit, (being sure to collect your personal belongings, purse, brief case, etc.) and alerting people as you go.
- 6) Once outside, move to the announced designated meeting area, and stay well away from the building. Do not leave this area until the Operations Manager or your supervisor knows you are leaving. Keep clear of emergency vehicles.
- 7) Do not return to the building until being told it is OK to do so by the Fire Dept. or Police.

### IN THE FIELD:

- 1) Notify the office, by radio, to report the fire to the fire department. Be sure to describe the location, type of fire and the area involved.
- 2) On a minor fire that appears to be controllable, promptly direct the charge of a fire extinguisher toward the base of the flame.
- 3) If in a remote area, coordinate to meet the Fire Dept. at a predetermined location to direct them to the area.

---

## VIOLENCE OR CRIMINAL BEHAVIOR

---

### IN THE OFFICE OR DISTRICT YARD:

Assist in making the Facility a safe place by being alert to suspicious situations.

- 1) If you witness any suspicious situations do not hesitate, CALL 911 and then, if safe, alert your supervisor or Operations Manager of the situation.
- 2) If you are the victim; or are involved in any on property violation of the law; or witness an on-property violation of the law, such as assault, robbery, theft, overt sexual behavior, etc., DO NOT TAKE ANY UNNECESSARY CHANCES. Notify your supervisor and call 911 and report the following:
  - a. Nature of incident.
  - b. Building location of incident.
  - c. Description of person(s) involved.
  - d. Description of property involved.
- 3) Assist the sheriff when they arrive by supplying them with additional information and ask others to do the same.
- 4) Report to your supervisor the existence of any person loitering or soliciting on District property. These people may be asked to leave if they do not have permission or a proper reason for being on the property. The Sheriff's Dept. is to be called if they refuse to leave when asked.

### IN THE FIELD:

- 1) Do not confront any trespasser(s) on District property.
- 2) If trespassers are observed stay at a safe distance and;
  - a. Report to the Operations Manager, by radio, the area and what activity is going on.
  - b. The Operations Manager will notify the Sheriff's Office who will respond to the area.

---

## EXPLOSION – AIRPLANE CRASH OR SIMILAR

---

### IN THE OFFICE OR YARD:

- 1) Immediately take cover under tables, desks and any other such objects, which will give you protection against glass or debris.
- 2) After the effects of the explosion have subsided, call 911. Give your name; describe the location and nature of the emergency.
- 3) Evacuate the building being sure to collect your personal belongings (purse, brief case, etc.) and:
  - a. Be aware of any structural damage.
  - b. Stay away from glass doors and windows.
  - c. Do not touch or move any suspicious objects.
- 4) Assist others, especially the injured and handicapped in the evacuation of the building.
- 5) Once outside, move to the announced designated meeting area, away from the affected area. Keep clear of emergency vehicles. Do not leave this area until the Operations Manager or your supervisor knows you are leaving.
- 6) To the best of your ability, and without re-entering the building, determine if everyone has evacuated safely.
- 7) Do not return to the building until being told it is OK to do so by the Fire Dept. or Police.

### IN THE FIELD:

- 1) Notify the office by radio, cell phone, or other means the location, the extent of the incident, and what assistance you need.
- 2) Do not touch or move any suspicious objects.
- 3) Keep a safe distance until emergency help arrives.

---

## EARTHQUAKE

---

### IN THE OFFICE OR YARD:

- 1) During an earthquake remain calm and quickly follow the steps outlined below.
- 2) If indoors, seek refuge in a doorway or under a desk or table. Stay away from glass windows shelves and anything else that might fall.
- 3) If outdoors, move quickly away from buildings, utility poles and other structures.
- 4) After the initial shock, evaluate the situation and if emergency help is necessary, call 911. Protect yourself at all times and be prepared for aftershocks.
- 5) Coordinate with management and begin turning off all potentially hazardous equipment such as gas and electric appliances. Damaged facilities should be reported.
- 6) Evacuate the building by quickly walking to the nearest exit, alerting people as you go. Be aware of structural damage and assist both the handicapped and injured. DO NOT RUN.
- 7) Once outside, move to the announced designated meeting area away from the building. Keep clear of emergency vehicles. Do not leave this area until the Operations Manager or your supervisor knows you are leaving.
- 8) Do not return to the building until told to do so by police and fire personnel.

### IN THE FIELD:

- 1) Pull over to the side of the road, away from possible falling objects like power lines, telephone poles, trees, buildings, etc. and stay in your vehicle.
- 2) Report to the main office as soon as it is safe to travel. If it is not safe to travel, contact the office or another unit by radio informing them of your location and situation.



**SUBJECT: EMERGENCY NOTIFICATION PROCEDURE OF AMMONIA RELEASE,  
WATER DEPARTMENT**

Ammonia stations are equipped with a Telemetry Alarm System that when activated will page the “on-call” System Operator. If there is no response with 30 minutes, the Operation Manager will then be called.

**REGULAR WORKING HOURS (7:00 AM TO 4:30 PM):**

Fallbrook Service Area:	Cellular Phone #
Standby System Operator	760-497-4096

**AFTER HOURS, WEEKENDS AND HOLIDAYS:** Incoming calls to the District's answering service (760728-1125) will be given to the water department on-call duty person who will be responsible for notifying the following personnel.

Name	Cellular Phone #
Standby System Operator	760-497-4096
Water System Supervisor	760-497-5777
Operations Manager	760-497-4103

## **Article 21. Records Retention and Destruction Policy**

### Sec. 21.1 Purpose.

The purpose of this policy is to provide guidelines to staff regarding the retention or disposal of District records; provide for the identification, maintenance, safeguarding and disposal of records in the normal course of business; ensure prompt and accurate retrieval of records; and ensure compliance with legal and regulatory requirements.

### Sec. 21.2 Authorization to Implement Policy.

The General Manager is authorized by the Board of Directors to interpret and implement this policy, and to cause to be destroyed any or all such records, papers and documents that meet the qualifications governing the retention and disposal of records, as specified below.

### Sec. 21.3 Government Code (Chapter 7) Sections Providing for the Destruction of Records of Special Districts:

60200. Duplicate records, papers, or documents. The retention and disposal of records by the Fallbrook Public Utility District, the legislative body of any special district may authorize at any time the destruction or disposition of any duplicate record, paper, or document, the original or a permanent photographic record of which is in the file of any officer of a department of the District.

60201. Records, papers or documents more than two years old and prepared or received other than pursuant to statute. The legislative body of a district may authorize the destruction or disposition of any record, paper, or document which is more than two years old and which was received in any manner other than pursuant to state statute. Such records, papers, or documents need not be photographed, reproduced, or microfilmed prior to destruction and no copy thereof need be retained.

60202. Unaccepted bids for construction of public works more than two years old. The legislative body of a district may authorize the destruction of any unaccepted bid or proposal for the construction or installation of any building, structure or other public work, which is more than two years old.

60203. Records, papers, or documents not required to be filed: Conditions. The legislative body of a district may authorize the destruction of any record, paper, or document that is not expressly required by law to be filed and preserved if all of the following conditions are complied with:

- a. The record, paper, or document is photographed, microphotographed, or reproduced by electronically recorded video images on magnetic surfaces, recorded in the electronic data processing system, recorded on optical disk, or any other medium which does not permit additions, deletions, or changes to the original document in compliance with the minimum standards or guidelines, or both, as recommended by the American National Standards Institute or the Association for Information and Image Management for recording of permanent records or non-permanent records, whichever applies;

- b. The device used to reproduce the record, paper, or document on film optical disk or any other medium is one which accurately reproduces the original thereof in all details, and which does not permit additions, deletions, or changes to the original document images;
- c. The photographs, microphotographs, or other reproductions on film or any other medium are placed in conveniently accessible files and provision is made for preserving, examining, and using the files.

For the purpose of this section, every reproduction shall be deemed to be an original record and a transcript, exemplification, or certified copy, as the case may be, of the original.

Sec. 21.4 State Controller's Guidelines.

The basic guidelines for destruction of records of special districts is in Government Code Sections 60200 through 60203 recorded above. The following is supplementary information and intends to define an acceptable records retention and destruction guide for special districts.

- A. Accounting Records. Include but are not limited to the following:
  - 1. Source Documents
    - a) Invoices
    - b) Purchase Orders
    - c) Deposit Permits
    - d) Warrants
    - e) Vouchers
    - f) Requisitions
    - g) Receipts
    - h) Claims
    - i) Bank Statements
    - j) Bank Deposits
    - k) Checks
    - l) Bills
    - m) Various accounting authorizations taken from Board minutes, resolutions, or contracts.
  - 2. Journals
    - a) Cash Receipts or Disbursement Book
    - b) Note Register
    - c) Deposit Permit Register
    - d) Accounts Receivable or Payable Register
    - e) Check or Warrant Register
    - f) General Journal
    - g) Payroll Journal

3. Ledgers
  - a) Expenditure
  - b) Revenue
  - c) Taxes Receivable
  - d) Accounts Payable or Receivable Ledger
  - e) Warrants Payable
  - f) Construction
  - g) Appropriation
  - h) General Ledger
4. Trial Balance
5. Adjusting Entries
6. Statements (Interim or Certified – Individual or All Fund)
  - a) Balance Sheet
  - b) Analysis of Changes in Available Fund Balance
  - c) Cash Receipts
  - d) Expenditures
  - e) Revenues
  - f) Changes in Bonded Indebtedness
  - g) Profit and Loss
  - h) Changes in Fixed Assets
7. Closing Entries
8. Reversing Entries
9. Other
  - a) Schedule of Investments
  - b) Long Term Debt Records
  - c) Inventory Records
  - d) Capital Asset Records
  - e) Lease-Purchase Records
  - f) Depreciation Schedule
  - g) Cost Accounting Records
  - h) Budgets
  - i) Petty Cash Records

B. Retention of Accounting Records.

All Accounting Records should be retained indefinitely in their original form until the governing body gives authorization for destruction.

1. Any accounting record except the Journals and Ledgers which are more than five years old and which were prepared or received in any manner other than pursuant to State Statute may be authorized for destruction, provided that:

- a. There is no continuing need for said record, i.e., long-term transactions, special projects, pending litigations, etc., and;
  - b. There exists in a permanent file, an audit report or reports covering the inclusive period of said record, and that;
  - c. Said audit report or reports were prepared pursuant to procedures outlined in Government Code Section 26909 and other State or Federal audit requirements, and that;
  - d. Said audit(s) contains the expression of an unqualified opinion.
2. Any accounting record created for a specific event or action may be destroyed upon authorization five years from the end of the fiscal period to which it applies.
  3. Any source document detailed in a register, journal, ledger or statement may be authorized for destruction five years from the end of the fiscal period to which it applies.
  4. The following may be destroyed at any time:
    - a. Duplicates (original-subject to aforementioned requirements)
    - b. Rough drafts, notes or working papers (except audit).
    - c. Cards, listings, nonpermanent indices, other papers used for controlling work or transitory files.

C. Retention of Payroll and Personnel Records.

1. All payroll and personnel records should be retained indefinitely. Originals may upon authorization be destroyed after seven years retention, provided said records have been microfilmed and qualify for destruction under Government Code Section 60203 with its various conditions. Payroll and personnel records include the following:
  - a. Accident reports, injury claims and settlements.
  - b. Medical histories
  - c. Injury frequency charts
  - d. Applications, changes and terminations of employees
  - e. Insurance records of employees
  - f. Time sheets
  - g. Job descriptions
  - h. Performance evaluations
  - i. Earning records and summaries
  - j. Retirement records
2. The following associated with personnel records should be retained five years after termination:

- a. Fidelity bonds
- b. Garnishments

D. Retention of Assessing and Tax Collecting Records.

- 1. All assessing records may, upon authorization be destroyed after seven years retention from lien date; however, these records may be destroyed three years after the lien date when said records are microfilmed as provided for in Government Code Section 60203. (Revenue & Taxation Code Section 465)
- 2. Any original unsecured tax roll may upon authorization be destroyed after five years if the delinquent roll or abstract list has been certified as correct and complete by the county auditor or district auditor. (Revenue & Taxation Code Section 2928)
- 3. All tax rolls may upon authorization be destroyed after twelve years retention, if all necessary data needed from the secured delinquencies has been transferred to a delinquency abstract, which should be retained indefinitely. (Revenue & Taxation Code Section 4377)

E. Retention of Records Concerning Long-Term Debt.

- 1. Records of proceedings for the authorization of long-term debt, bonds, warrants, loans, etc., after issuance or execution, may be destroyed if microfilmed as provided for in Government Code Section 60203.
- 2. Terms and conditions of bonds, warrants, and other long-term agreements should be retained until final payment, and thereafter may be destroyed in less than ten years if microfilmed as provided for in Government Code Section 60203.
- 3. Paid bonds, warrant certificates and interest coupons may be destroyed after six months if detailed payment records are kept for ten years.

F. Retention of Minutes.

Minutes of the meetings of the Board of Directors are usually retained indefinitely in their original form. However, they may, upon authorization, be destroyed if said minutes are microfilmed as provided for in Government Code Section 60203.

G. Retention of Construction Records.

Construction records, such as bids, correspondence, change orders, etc., should not be kept in excess of seven years unless they pertain to a project

which includes a guarantee or grant and, in that event, they should be kept for the life of the guarantee or grant plus seven year. As-built plans for any public facility or works should be retained as long as said facility is in existence. Unaccepted bids may be destroyed after two years.

H. Retention of Contracts.

Contracts should be retained for their life plus seven years.

I. Retention of Property Records.

Property records, such as documents of title, should be kept until the property is transferred or otherwise no longer owned by the District.

Sec. 21.5 General Provisions

21.5.1 Public Records Policy.

Public records of the District shall be open to inspection during regular office hours of the District. "Public Records" are all records of the District except those which are exempted from disclosure by the California Public Records Act (Government Code 6250 et. seq.)

21.5.2 Definitions.

A. "Public Records" includes any writing containing information relating to the conduct of the public's business prepared, owned, used or retained by the District regardless of physical medium or characteristics.

B. "Writing" means handwriting, typewriting, printing, Photostatting, photographing, and every other means of recording upon any form of communication or representation, including letters, words, pictures, sounds, or symbols, or a combination thereof and all papers, maps, magnetic or paper tapes, photographic films and prints, magnetic or punched cards, discs, drums, and other documents.

21.5.3 Records Exempt from Disclosure.

In accordance with Government Code Section 6254, the following records are exempt from disclosure and shall not be disclosed:

A. Preliminary drafts, notes or interagency or interdistrict memoranda which are not retained by the District in the ordinary course of business, provided that the public interest in withholding such records clearly outweighs the public interest in disclosure.

B. Records pertaining to pending litigation to which the District is a party, or to claims made pursuant to Division 3.6 (commencing with Section 810) of Title 1 of the Government Code, until such litigation or claim has been finally adjudicated or otherwise settled.

C. The District Server backs up all Electronic mail (“E-mail”) daily and retains said e-mail backups for a period of nine (9) days and then it is subject to permanent deletion. This shall include any and all business and personal E-mail that has been saved to any folder or subfolder within any and all user Outlook Profiles on District Mail Servers. It is the responsibility of the user of the District’s E-mail system to print a paper hardcopy, and file appropriately, any e-mails that are considered part of the official record of District business (e.g., contracts or changes, legal correspondence, invoices, etc.). The District shall not be responsible for the retention, backup, or recovery of any personal e-mails.

In the event of litigation to which the District is a party or reasonably anticipates becoming a party, the email users who generate emails relevant to litigation, including, but not limited to, emails, email attachments, Microsoft Word documents, Microsoft Excel spreadsheets, and Power Point presentations, shall print a hard copy of each potentially relevant document to the litigation as it is generated or received (including communications with attorneys or other relevant outside parties that could be protected by applicable privileges) and deliver each hard copy to the Board Secretary for filing in a central litigation file.

D. Personnel, medical or similar files, the disclosure of which would constitute an unwarranted invasion of personal privacy.

E. Geological and geophysical data, plant production data and similar information relating to utility systems development, or market or crop reports, which are obtained in confidence from any person.

F. Test questions, scoring keys, and other examination data used to administer a licensing examination, examination for employment or academic examination.

G. The contents of real estate appraisals, engineering or feasibility estimates and evaluations made for or by the District relative to the acquisition of property, or to prospective public supply and construction contracts, until such time as all the property has been acquired or all of the contract agreements obtained, provided, however, the law of eminent domain shall not be affected by this provision.

H. Information required from any taxpayer in connection with the collection of local taxes, which is received in confidence, and the disclosure of the information to other persons would result in unfair competitive disadvantage to the person supplying such information.

I. Library and museum materials made or acquired and presented solely for reference or exhibition purposes.

J. Records the disclosure of which is exempted or prohibited pursuant to provision of federal or state law, including but not limited to, provisions of the Evidence Code relating to privilege.



#### 21.5.4 Government Code 6255.

The District shall withhold from inspection any record that is exempt under the express provisions of the California Public Records Act, including those items set forth above, and may withhold any other record if on the facts of the particular case the public interest served by not making a record public clearly outweighs the public interest served by disclosure of the record.

#### 21.5.5 Right of Privacy.

The Board of Directors has determined that the public interest is served by not making public the names, addresses and billing information regarding its customers since the indiscriminate disclosure of such information could constitute an undue invasion of the right of privacy of its customers. Any person seeking such information may file a written appeal with the Secretary of the District. Thereafter, the Board of Directors shall on the facts of the particular case determine whether the public interest served by not making the record public clearly outweighs the public interest served by disclosure of such record. However, nothing herein shall preclude any District employee, including members of the board of directors, access to customer billing information necessary to carry out the regular duties of such employees including the resolution of customer service issues.

#### 21.5.6 Procedures for Access to Public Records.

A. Any person desiring to inspect any public record shall identify himself and shall identify the records to be inspected. Exception: Statements of Economic Interest filed pursuant to Government Code Section 81008 (The Political Reform Act of 1974).<sup>1</sup>

B. The Secretary of the District shall determine whether the requested record is subject to inspection. If the Secretary of the District is uncertain whether the record is exempt from disclosure under the California Public Records Act, or whether the facts of the particular case indicate the public interest is served by not making the record public clearly outweighs the public interest served by disclosure of the record, she shall consult with Counsel for the District.

If the Secretary of the District refuses to permit inspection of any record, the person seeking such inspection may appeal the decision of the Secretary of the District to the Board of Directors. Such appeal shall be in writing and shall be filed with the Secretary of the District not later than 10 working days after the refusal of the Secretary of the District to permit inspection.

---

<sup>1</sup> Government Code Section 81008 states, “no conditions whatsoever shall be imposed upon persons desiring to inspect or reproduce reports and statements filed under this title, not shall any information or identification be required from such persons”.

C. The Board of Directors shall consider and rule upon the appeal within 30 days after the filing thereof, and shall thereupon notify the applicant in writing of its decision. If the applicant has filed a written appeal with the Board, the applicant shall be notified of the time and place of the meeting of the Board to consider the matter, and the applicant may appear in person before the Board when the matter is heard. If the Board fails to give written notice of its decision within 30 days of the filing of the appeal, the appeal shall be deemed denied.

D. Inspection of public records shall be made only in the District office, and no document shall be removed there from. A representative of the District may be present during the inspection of any records.

E. The District will make every effort to cooperate with the person seeking to inspect documents; however, if the request is to inspect a substantial quantity of documents or documents not readily available, the District shall have a reasonable period of time to collect such records and may require the inspection of such records to take place at a future date.

F. Any person may obtain a copy of any identifiable public record. Upon request, an exact copy shall be provided unless impracticable to do so. Computer data shall be provided in a form determined by the District.

G. A request for a copy of an identifiable written public record, or information produced there from or a certified copy of such record shall be accompanied by payment of a fee in the amount of \$0.25 for the first page and \$0.10 for each page thereafter. In some cases, it may be necessary to send a document or document(s) to a printer or commercial copying service; and in such cases, the person requesting copies shall pay the total direct cost. Blueprint reproduction shall be \$5.00 per print, plus staff time in excess of one-half hour. A request for a copy of a tape recording of a meeting of the Board of Directors of the District shall be accompanied by payment of a fee of \$10.00.

H. This public records policy of the District shall at all times be subject to the California Public Records Act, that it may be amended from time to time, and if there is any conflict between that act and this policy, the act shall prevail.

#### 21.5.7 Records Retention and Destruction Policy.

All records identified in the records retention schedules attached hereto shall be retained in original form in the District offices for the number of years indicated in the column designated, "Responsible Department".

Upon transfer to archives, any identical copies or duplicates shall be destroyed and the original shall be stored for the number of years indicated in the column designated, "open/active".

The column designated as “closed” indicates the disposition of a record after reaching its retention period.

The column designated as “disposal” indicates how the record is to be disposed of, whether it be archived, tossed, or shredded.

The column designated as “notes” shall designate specific information relating to a particular document and how it is to be retained or destroyed. It may also contain miscellaneous notes pertinent to the specific document.

No record shall be destroyed without the written authorization from the department manager and the general manager. If the department manager and/or the general manager have determined that the record has continuing value due to litigation or any other reason, it shall be retained either in original form or by microfilming or imaging.

Sec. 21.6 California Public Records Act.

The California Public Records Act is made a part of Article 21 and incorporated as Exhibit “A” attached.

Sec. 21.7 Records Retention Schedule.

The District’s Records Retention Schedule is made a part of Article 21 and incorporated as Exhibit “B” attached.

<sup>1</sup> The following requirements apply to microfilming:

- (1) The item must be photographed; microphotographed; reproduced by electronically recorded video images on magnetic surfaces; recorded on optical disk; reproduced on film or any other medium which does not permit additions, deletions or changes to the original document in compliance with the minimum standards and/or guidelines as recommended by the American National standards Institute or the Association for Information and Image Management for recording of permanent records or nonpermanent records, whichever applies; and
- (2) The original must be accurately reproduced in all details; and
- (3) The reproductions must be stored in conveniently accessible files, and provision must be made for preserving, examining and using the files.

ARTICLE 32 (Renumbered as Article 21 by Resolution 5006)
New policy added 2/28/05
Sec. 32.5.3(C) – Rev. 10/06
Records Retention Schedule (Email) – Rev. 10/06
Exhibit B – Rev. 2/10
Exhibit A – Rev. 12/10
Exhibit B – Rev. 8/11

**Article 22. Social Media Policy and Procedure**

Sec. 22.1 General Purpose.

This Social Media Policy ("Policy") establishes guidelines for the establishment and use by the Fallbrook Public Utility District ("District") of social media sites as a means of conveying information to members of the public. The intended purpose of District social media sites is to disseminate information from the District about the District's mission, meetings, activities, and current issues to members of the public. The District has an overriding interest and expectation in protecting the integrity of the information posted on its social media sites and the content that is attributed to the District and its officials.

Sec. 22.2 Definitions.

The following words and phrases whenever used in these Policies and Procedures shall have the meaning defined in this section:

Sec. 22.2.1 "Social media sites" means content created by individuals, using accessible, expandable, and upgradable publishing technologies, through and on the internet. Examples of social media include, but are not limited to, Facebook, Twitter, Instagram, Blogs, RSS, YouTube, and LinkedIn.

Sec. 22.2.2 "District social media sites" means social media sites which the District establishes and maintains, and over which it has control over all postings, except for advertisements or hyperlinks by the social media site's owners, vendors, or partners. District social media sites shall supplement, and not replace, the District's required notices and standard methods of communication.

Sec. 22.2.3 "Posts" or "postings" means information, articles, pictures, videos or any other form of communication posted on a District social media site.

Sec. 22.3 General Policy.

Sec. 22.3.1 The District's official website at [www.fpud.com](http://www.fpud.com) (or any domain owned by the District) will remain the District's primary means of internet communication.

Sec. 22.3.2 The establishment of District social media sites is subject to approval by the General Manager or his/her designee. Upon approval, District social media sites shall bear the name and/or official logo of the District.

Sec. 22.3.3 Content on District social media sites is subject to oversight by the General Manager's Department.

Sec. 22.3.4 District social media sites shall clearly state that such sites are

maintained by the District and that the sites comply with the District's Social Media Policy.

Sec. 22.3.5 District social media sites shall link back to the District's official website for forms, documents, online services, and other information necessary to conduct business with the District whenever possible.

Sec. 22.3.6 The District's Public Affairs Specialist shall monitor content on District social media sites to ensure adherence to both the District's Social Media Policy and the interest and goals of the District.

Sec. 22.3.7 District social media sites shall be managed consistent with the Brown Act. Members of the District's Board of Directors shall not respond to, "like", "share", retweet, or otherwise participate in any published postings, or use the site or any form of electronic communication to respond to, blog, or engage in serial meetings, or otherwise discuss, deliberate, or express opinions on any issue within the subject matter jurisdiction of the body.

Sec. 22.3.8 The District reserves the right to terminate any District social media site at any time without notice.

Sec. 22.3.9 District social media sites shall comply with usage rules and regulations required by the site provider, including privacy policies.

Sec. 22.3.10 The District's Social Media Policy shall be displayed to users or made available by hyperlink.

Sec. 22.3.11 All District social media sites shall adhere to applicable federal, state, and local laws, regulations, and policies.

Sec. 22.3.12 District social media sites are subject to the California Public Records Act. Any content maintained on a District social media site that is related to District business, including a list of subscribers, posted communication, and communication submitted for posting, may be considered a public record and subject to public disclosure.

Sec. 22.3.13 Employees representing the District on District social media sites shall conduct themselves at all times as a professional representative of the District and in accordance with all District policies.

Sec. 22.3.14 All District social media sites shall utilize authorized District contact information for account set-up, monitoring, and access. The use of personal email accounts or phone numbers by any District employee is not allowed for the purpose of setting-up, monitoring, or accessing a District social media site.

Sec. 22.3.15 District social media sites may contain content, including but not

limited to, advertisements or hyperlinks over which the District has no control. The District does not endorse any hyperlink or advertisement placed on District social media sites by the social media site's owners, vendors, or partners.

Sec. 22.3.16 The District reserves the right to change, modify, or amend all or part of this policy at any time.

Sec. 22.4 Content Guidelines.

Sec. 22.4.1 The content of District social media sites should only pertain to District-sponsored or District-endorsed programs, services, and events. Content includes, but is not limited to, information, photographs, videos, and hyperlinks.

Sec. 22.4.2 Content posted to the District's social media sites must contain hyperlinks directing users back to the District's official website for in-depth information, forms, documents, or online services necessary to conduct business with the Fallbrook Public Utility District, whenever possible.

Sec. 22.4.3 The District shall have full permission or rights to any content posted, including photographs and videos.

Sec. 22.4.4 Any employee authorized to post items on any of the District's social media sites shall review, be familiar with, and comply with the social media site's use policies and terms and conditions.

Sec. 22.4.5 Any employee authorized to post items on any of the District's social media sites shall not express his or her own personal views or concerns through such postings. Instead, postings on any of the District's social media sites by an authorized District employee shall only reflect the views of the District.

Sec. 22.4.6 Postings must contain information that is freely available to the public and not be confidential as defined by any District policy or state or federal law.

Sec. 22.4.7 Postings may NOT contain any personal information, except for the names of employees whose job duties include being available for contact by the public.

Sec. 22.4.8 Postings to District social media sites shall NOT contain any of the following:

Sec. 22.4.8.1 Comments that are not topically related to the particular posting being commented upon;

Sec. 22.4.8.2 Comments in support of, or opposition to, political campaigns, candidates or ballot measures;

Sec. 22.4.8.3 Profane language or content;

Sec. 22.4.8.4 Content that promotes, fosters, or perpetuates discrimination on the basis of race, creed, color, age, religion, gender, marital status, or status with regard to public assistance, national origin, physical or mental disability or sexual orientation, as well as any other category protected by federal, state, or local laws;

Sec. 22.4.8.5 Sexual content or links to sexual content;

Sec. 22.4.8.6 Solicitations of commerce;

Sec. 22.4.8.7 Conduct or encouragement of illegal activity;

Sec. 22.4.8.8 Information that may tend to compromise the safety or security of the public or public systems; or

Sec. 22.4.8.9 Content that violates a legal ownership interest of any other party.

Sec. 22.4.9 These guidelines shall be displayed to users or made available by hyperlink on all District social media sites. Any content removed based on these guidelines must be retained, including the time, date, and identity of the poster, when available.

Sec. 22.4.10 The District reserves the right to implement or remove any functionality of its social media sites, when deemed appropriate by the General Manager or his/her designee. This includes, but is not limited to, information, articles, pictures, videos, or any other form of communication that is posted on a District social media site.

Sec. 22.4.11 Except as expressly provided in this Policy, accessing any social media site shall comply with all applicable District policies pertaining to communications and the use of the internet by employees, including email content.

Sec. 22.4.12 All of the content on District social media sites is subject to oversight by the General Manager's Office. The District reserves the right to change, modify, or amend all or part of this policy at any time.

**ARTICLE 33 (Renumbered  
as Article 22 by Resolution  
5006)**

Adopted in its Entirety – 9/18

## M E M O

**TO:** Board of Directors  
**FROM:** Engineering & Operations Committee  
**DATE:** February 22, 2021  
**SUBJECT:** Request for Approval to Purchase One Boom Truck Crane

---

Description

This request is for approval from the Board to purchase one boom truck crane from Velocity Truck Centers.

Purpose

Vehicle 1324, a 1987 Dresser crane, is due for replacement. This equipment has served more than 30 years in the District fleet and is no longer CARB compliant. In addition, due to its age, parts are getting difficult to obtain, resulting in more expense and longer downtime when repairs are needed. This is the oldest piece of equipment in the District fleet and will need extensive costly repairs in order to extend its service life. The crane is a key component to the valve replacement program and is used to replace valve clusters safely. The crane is also regularly used at the Water Reclamation Plant for repairs and maintenance.

After reviewing available options, staff determined a boom truck crane would be most efficient as a replacement. By utilizing a boom truck, staff will be able to drive the crane to the work site with all materials loaded on the bed. As the design of this boom truck is smaller, more maneuverability will be possible on some of Fallbrook's more condensed roads. Finally, because the boom truck can drive easily on surface streets, a separate truck and trailer will not be required to transport the crane, saving fuel costs and wear-and-tear on other fleet assets.

The RFQ for this procurement was sent to five vendors on January 27th – two responses were received – one from Manitex International for \$337,042.00 and one from Velocity Truck Centers for \$314,627.03.

Budgetary Impact

This crane was specified for purchase in the FY 20-21 Adopted Annual Budget; a total of \$250,000 was earmarked out of \$566,000 for overall fleet funding. If approved, the crane will cost \$64,627.03 more than originally projected.

Recently, the Board approved the purchase of 4 trucks from Courtesy Chevrolet in the amount of \$112,860.13, which was a savings of \$87,139.87 from its original projection (\$200,000). That savings will be applied towards this crane purchase, ensuring the totality of fleet procurements will remain within the overall \$566,000 total.

After purchasing this boom truck crane, \$138,512.84 will remain in the overall fleet budget.



Recommended Action

That the Board approve the purchase of one boom truck crane from Velocity Truck Centers in the amount of \$314,627.03.



**Vehicle/Equipment Evaluation Form**

**Vehicle VIN:** 5043-5001/4D 219821 U009705

**Vehicle or Equipment #:** 1324

**Make:** Dresser

**Model:** 150FA

**Year:** 1987

**Mileage:** N/A

**Hours of Operation:** 3834

**Date of Evaluation:** 2/10/2021

System	Points	Comments
Mileage/Hours	4	Over 3,000 hours
Annual Maintenance Cost	2	
Year	4	Oldest piece of heavy equipment in fleet
Downtime	2	Hard to obtain parts for



POINT RANGES	
Under 3 points	Condition I : EXCELLENT
4 – 7 points	Condition II : GOOD
8 – 11 points	Condition III : QUALIFIES FOR REPLACEMENT
12 or more	Condition IV : IMMEDIATE ATTENTION NEEDED

Mileage:

Under 15,000 miles – 0 points  
 15,001 – 35,000 miles – 1 point  
 35,001 – 50,000 miles – 2 points  
 50,001 – 75,000 miles – 3 points  
 75,001 miles or more – 4 points

Annual Maintenance Cost:

Under \$1,500 – 0 points  
 \$1,501 - \$3,000 – 1 point  
 \$3,001 - \$5,000 – 2 points  
 \$5,001 - \$7,500 – 3 points  
 \$7,501 or more – 4 points

Year:

Less than 3 years old – 0 points  
 4 – 7 years old – 1 point  
 8 – 11 years old – 2 points  
 12 – 15 years old – 3 points  
 15 years old or more – 4 points

Downtime:

Less than 1 week out of 1 year – 0 points  
 More than 1 week but less than 2 weeks out of 1 year – 1 point  
 More than 2 weeks but less than 3 weeks out of 1 year – 2 points  
 More than 3 weeks but less than 4 weeks out of 1 year – 3 points  
 More than 4 weeks out of 1 year – 4 points

## M E M O

**TO:** Board of Directors  
**FROM:** Jack Bebee, General Manager  
Paula C.P. de Sousa, General Counsel  
**DATE:** February 22, 2021  
**SUBJECT:** Public Hearing to Consider Adoption of Ordinance No. 349, Providing for an Increase in Board Member Compensation

---

Purpose

For the Board to hold a public hearing and consider whether to adopt an ordinance increasing the amount of per diem compensation for members of the Board from \$110.25 to \$115.76.

Summary

On February 24, 2020, the Board of Directors adopted Ordinance No. 346, setting the Board's per diem compensation at \$110.25 per day for each day's service rendered as a Director by order of the Board or as specified in Section 2.12 of the District's Administrative Code. Directors may only receive compensation from the District for a maximum of 10 days per month.

Under Water Code Section 20202, the Board may increase per diem compensation by up to five percent (5%) for each calendar year since the effective date of the last change to Board compensation. By law, the Board must hold a noticed public hearing to consider an increase in per diem compensation. An ordinance increasing per diem compensation may not take effect for sixty (60) days from the date of adoption and is subject to a referendum.

At its January 25, 2021 meeting, the Board of Directors directed staff to provide notice of a public hearing on February 22, 2021 to receive public comments regarding a proposed increase to the Board's per diem compensation from \$110.25 to \$115.76.

A public hearing notice (Attachment 1) was published in the Fallbrook and Bonsall Village News on February 4, 2021, and February 11, 2021. After holding the public hearing, the Board may consider adoption of Ordinance No. 349 (Attachment 2), which would set the new rate of compensation at \$115.76 effective April 26, 2021, unless the voters of the District successfully petition for a referendum on the ordinance. The ordinance would also update Section 2.12 of the District's Administrative Code to reflect the updated amount.

### Recommended Action

Hold the public hearing and consider adoption of Ordinance No. 349, to increase Board compensation from \$110.25 to \$115.76 for each day's service to the District and to update Section 2.12 of the District's Administrative Code to reflect the updated amount.

### Attachments

Attachment A: Copy of Public Hearing Notice

Attachment B: Proposed Ordinance No. 349

## **Attachment A**

NOTICE OF PUBLIC HEARING  
FALLBROOK PUBLIC UTILITY DISTRICT POTENTIAL INCREASE  
IN COMPENSATION FOR MEMBERS OF THE BOARD OF  
DIRECTORS

NOTICE IS HEREBY GIVEN that on February 22, 2021, the Board of Directors of the Fallbrook Public Utility District will hold a public hearing at 4:00 p.m., or as soon thereafter as practicable, as part of the Regular Meeting of the Board. Due to the COVID-19 State of Emergency and pursuant to the Brown Act waiver provided under the Governor's Executive Order, the meeting will be held via Webconference/Teleconference (via Zoom) and there will be no physical location from which members of the public may participate. The Board will hold the public hearing in order to receive oral and written testimony regarding the proposed adoption of Ordinance No. 349. Instructions for members of the public to observe the Board Meeting and the public hearing via Web Conference will be included in the February 22, 2021 meeting agenda.

Members of the public who wish to address the Board of Directors regarding Ordinance No. 349 may submit written testimony for receipt no later than 3:00 pm on February 22, 2021 (with a reading limit of no more than 3 minutes), by mail to the attention of the Board Secretary, at 990 E. Mission Rd., Fallbrook, CA 92028, by deposit in the District's payment drop box located at the above-mentioned address, or by e-mail to the Board Secretary at [leckert@fpud.com](mailto:leckert@fpud.com). Written testimony will be read to the Board during public hearing. Members of the public may also provide oral testimony during the public hearing via Webconference/Teleconference by following the instructions for public comment included in the February 22, 2021 meeting agenda. These public comment procedures supersede the District's standard public comment policies and procedures to the contrary.

Upon conclusion of the hearing, the Board will consider adoption of proposed Ordinance No. 349, which would increase the amount of compensation for members of the Board of Directors. Copies of proposed Ordinance No. 349 will be available upon posting of the agenda for the February 22, 2021 Regular Meeting of the Board by calling the District at (760) 728-1125 or at the District's web site: [www.fpud.com](http://www.fpud.com).

## **Attachment B**



**ORDINANCE NO. 349**

**AN ORDINANCE OF THE BOARD OF DIRECTORS OF THE  
FALLBROOK PUBLIC UTILITY DISTRICT  
SETTING THE AMOUNT OF PER DIEM COMPENSATION  
FOR THE BOARD OF DIRECTORS**

\* \* \* \* \*

**WHEREAS**, Public Utilities Code Section 16002 provides that the Board of Directors may increase the amount of per diem compensation that may be received by members of the Board by an ordinance adopted pursuant to Water Code Section 20200, *et seq.*; and

**WHEREAS**, on February 24, 2020, the Board of Directors adopted Ordinance No. 346, setting per diem compensation at \$110.25 per day; and

**WHEREAS**, Water Code Section 20202 provides that the District may increase the amount of compensation which may be received by members of the Board of Directors in an amount not to exceed five percent (5%) for each calendar year since the effective date of the last adjustment; and

**WHEREAS**, a public hearing to consider an increase in the compensation of the members of the Board was duly noticed in accordance with Water Code Section 20203 and Government Code Section 6066, and said hearing was held on the date hereof.

**BE IT ENACTED BY** the Board of Directors of Fallbrook Public Utility District as follows:

**SECTION I.** The Board of Directors of the District hereby amends Ordinance No. 327, "An Ordinance of the Board of Directors of the Fallbrook Public Utility District Authorizing an Increase in Compensation of Governing Board Members," Section 4, "Director Compensation," as follows:

**Section 4. DIRECTOR COMPENSATION**

Compensation for the Directors of the Governing Board for regular, adjourned and special meetings, to include occurrences set forth in Section 12.1.1 of the Administrative Code, is established at One Hundred Fifteen Dollars and Seventy-Six Cents (\$115.76) per day for each day's attendance. A Director shall not receive compensation for more than 10 days of service in a month. Increases will be subject to the requirements of California Public Utilities Code Section 16002 and California Water Code Section 20200 *et seq.*

**SECTION II.** All other provisions of Ordinance No. 327, as adopted on January 26, 2009, shall remain unchanged and in full effect.

**SECTION III.** Ordinance No. 346, adopted February 24, 2020, is hereby repealed and shall no longer be of any force or effect.

**SECTION IV.** Section 2.12 of the District's Administrative Code shall be revised to replace "One Hundred Ten Dollars and Twenty-Five Cents (\$110.25)" with "One Hundred Fifteen Dollars and Seventy-Six Cents (\$115.76)." All other provisions of Section 2.12 shall remain unchanged and in full force and effect.

**SECTION V.** If any clause or provision of this Ordinance is found to be void or unenforceable by a court of competent jurisdiction, the remaining provisions of this Ordinance shall nonetheless continue in full force and effect.

**SECTION VI.** This Ordinance shall be posted at three public places in the District and shall be caused to be published pursuant to Section 6061 of the Government Code in the Fallbrook Village News, a newspaper of general circulation. This Ordinance shall take effect on April 26, 2021, which date is one year from the operative date of the last adjustment and is no less than 60 days after its passage.

**PASSED AND ADOPTED** by the Board of Directors of the Fallbrook Public Utility District at a regular meeting of the Board held on the 22<sup>nd</sup> day of February, 2021, by a roll call vote, as follows:

AYES:  
NOES:  
ABSTAIN:  
ABSENT:

\_\_\_\_\_  
President, Board of Directors

ATTEST:

\_\_\_\_\_  
Secretary, Board of Directors

1. **MWD Issues**

SDCWA was awarded an additional \$326,918.34 in costs for the 2010/12 rate cases. The legal fees are still to be determined. SDCWA has requested that MWD provide them the \$44,373,872 which was previously awarded. The payment had previously been made to SDCWA, but the check was returned to MWD by SDCWA. It is unclear what will happen to the funds and if any will be refunded to member agencies.

2. **Regional Conveyance**

The Study is underway and it will likely be several months before there will be any updates on this project to build a second Colorado River Aqueduct. There has been continued outreach about the economic benefits of the project by SDCWA.

3. **FPUD/RMWD Detachment**

SDCWA has not provided any open session updates on the process. The next meeting on this with the Advisory committee is not expected until April.

4. **Urban Water Management Plan (UWMP)**

SDCWA will be taking their UWMP forward for adoption in February. There have been concerns raised by other agencies that the demand estimate is elevated by 10-20%. We are doing our own analysis of FPUD demands given the concerns raised by others.

5. **Key Upcoming Issues**

Some key issues for the upcoming year include:

- Developing a conservative low water demand projection for financial analysis and long-term planning.
- Reviewing the long-term fiscal sustainability of SDCWA and determining any structural changes to the rate structure.
- Implementing the new agricultural water program.
- Completing the next phase of the regional conveyance study and developing a plan to fund millions in additional project work if the project continues to be pursued.

Detailed updates on any of these items will be provided by the General Manager at the request of any Board members.



# Fallbrook Public Utility District

## Engineering and Operations FY21

Board Meeting February 2021

### Water PAYGO CIP FY21

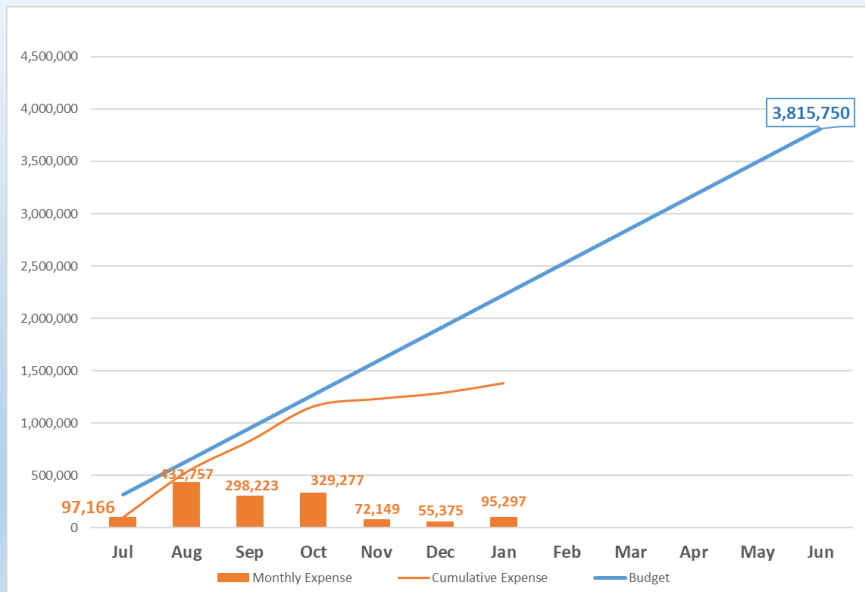

## Water SMRCUP CIP FY21

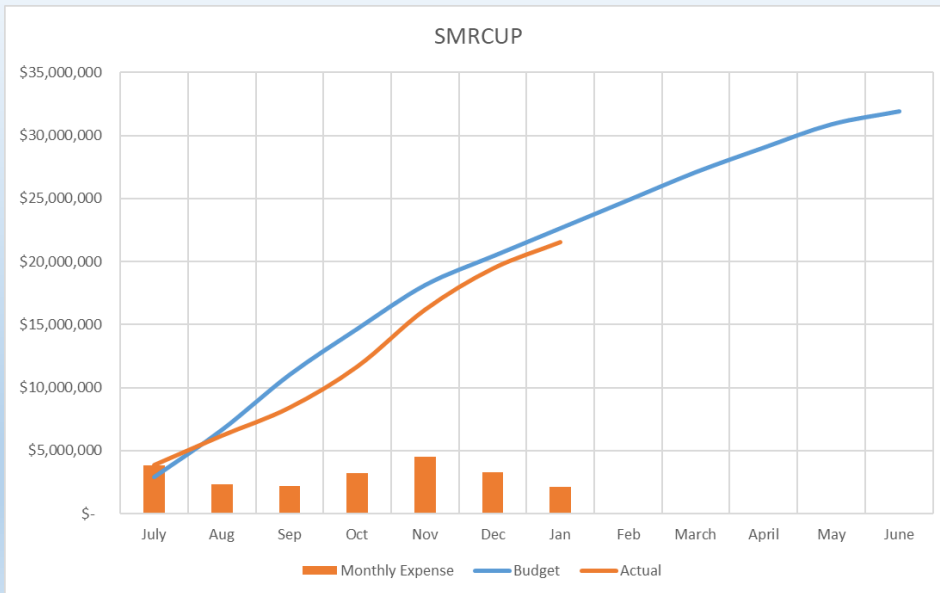

## Wastewater System CIP FY21

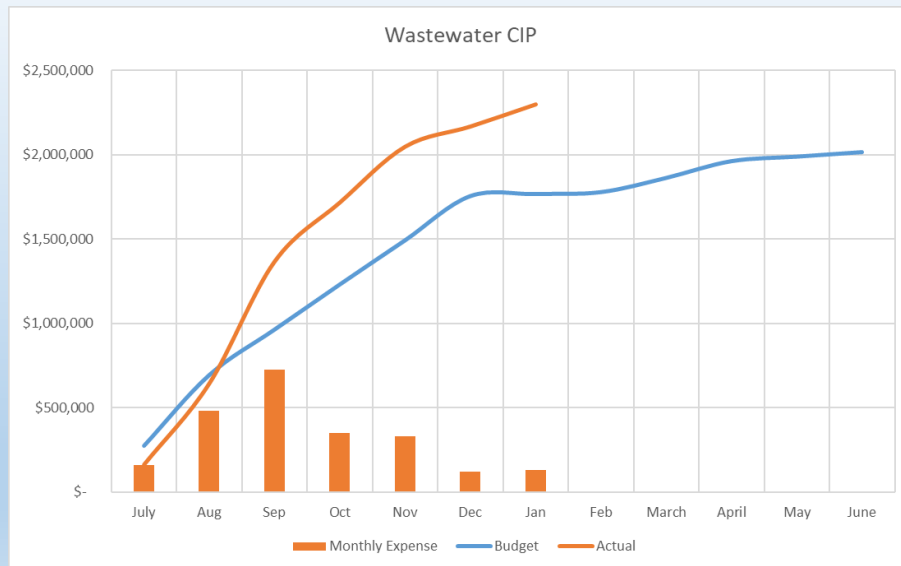

## Wastewater System Regulatory Compliance

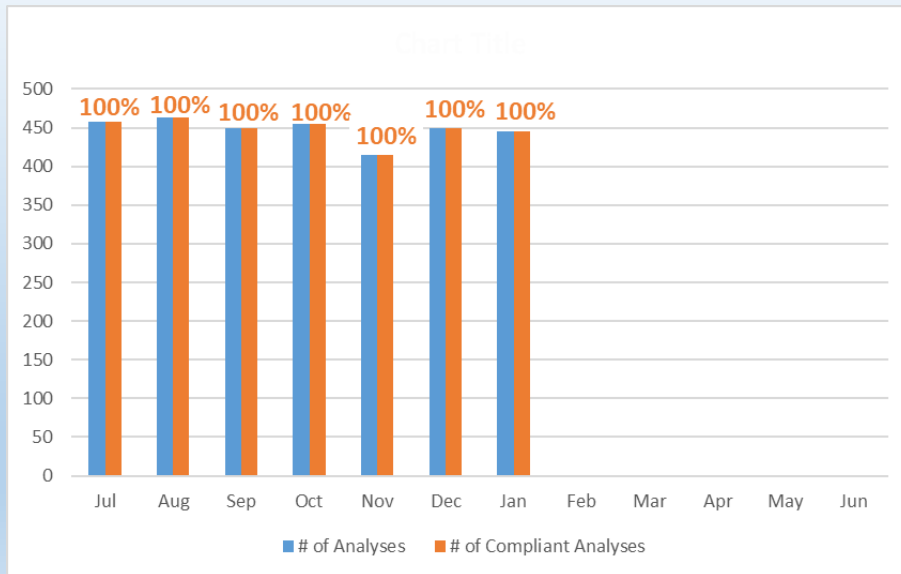

## Reclamation Plant – Preventative Maintenance Work Orders

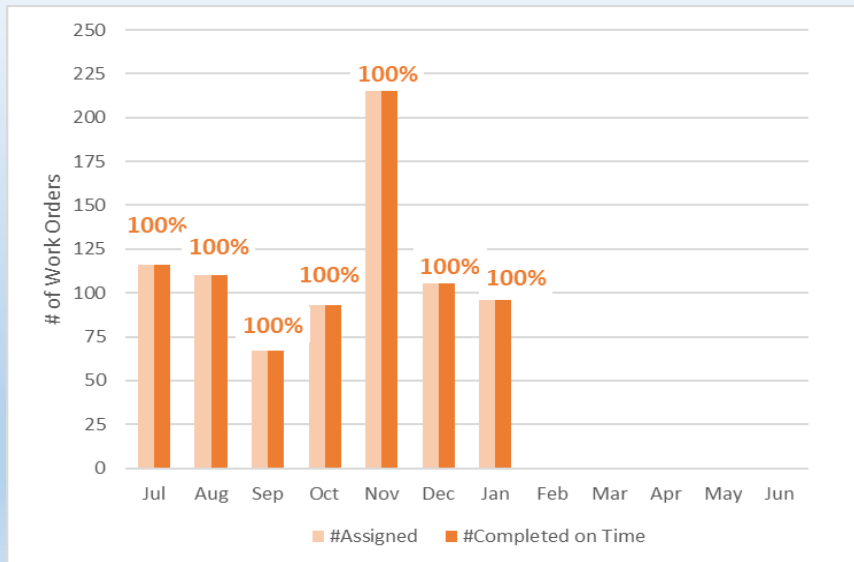

### Reclamation Plant – Energy Usage (KWh/MG Treated)

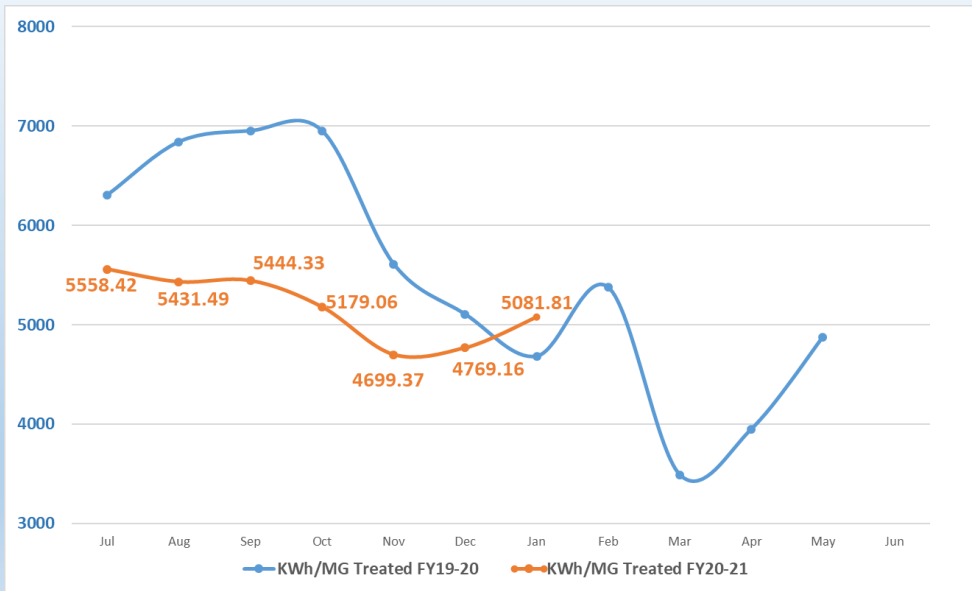

### Recycled Water – Time out of Service (Hours)

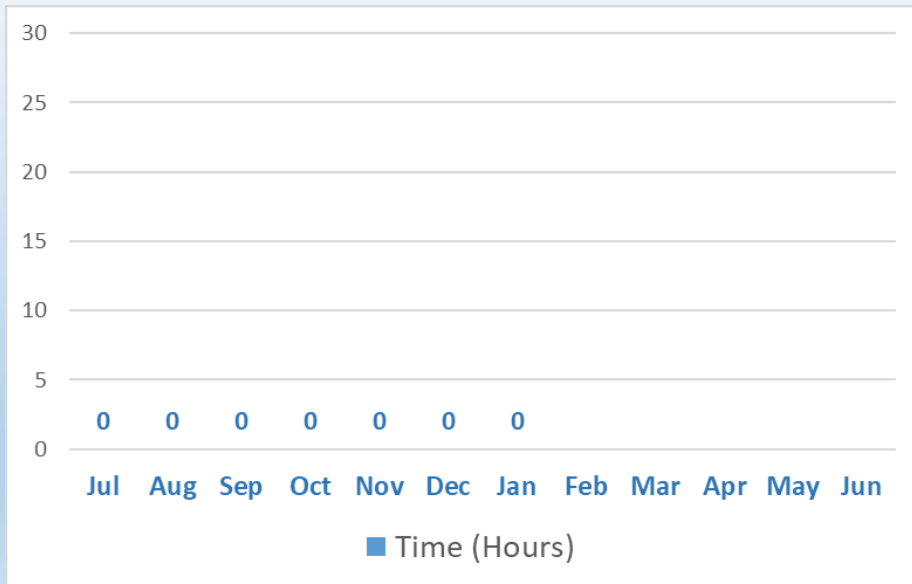

## Sewer Overflows

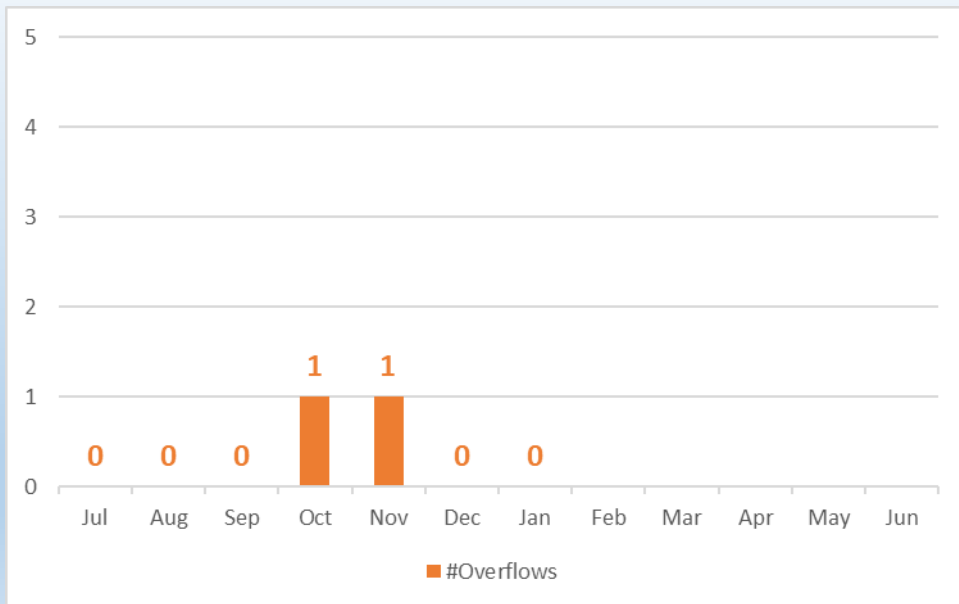

## Wastewater Spilled

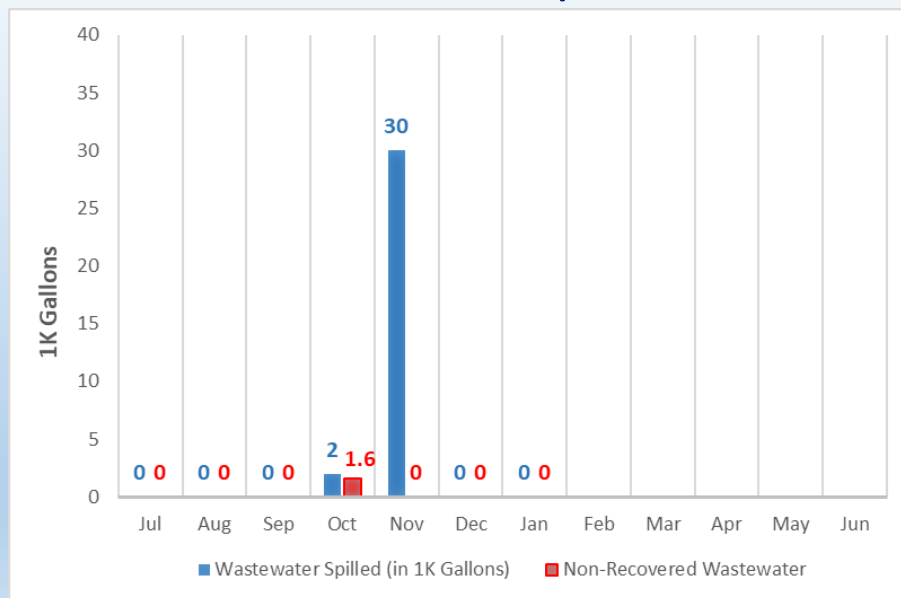



## Wastewater System Odor Complaints

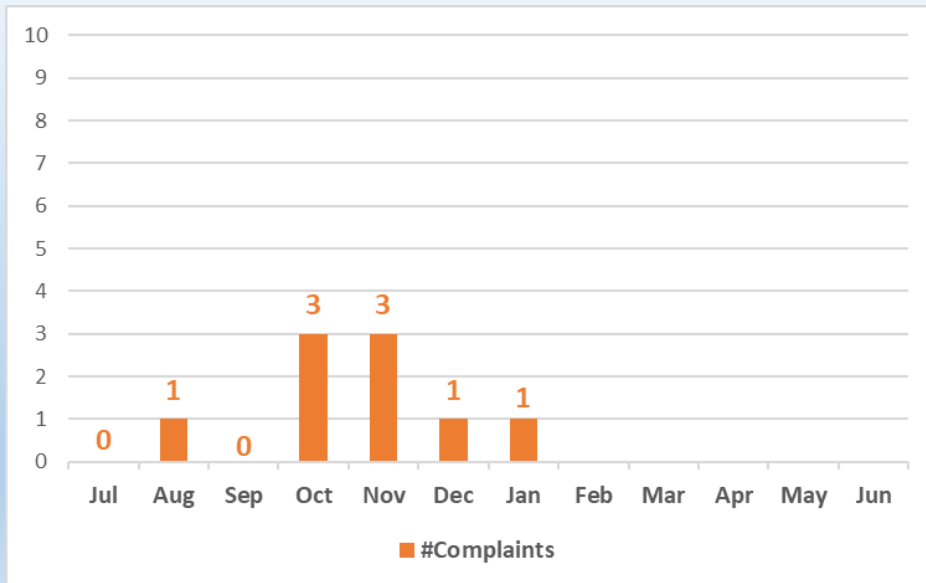

## Collections – Preventative Maintenance Work Orders

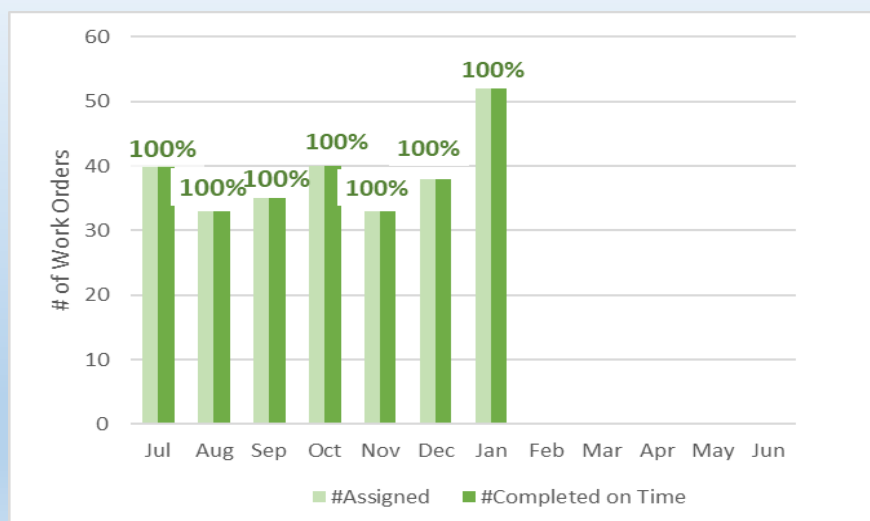

## Meter Exchange

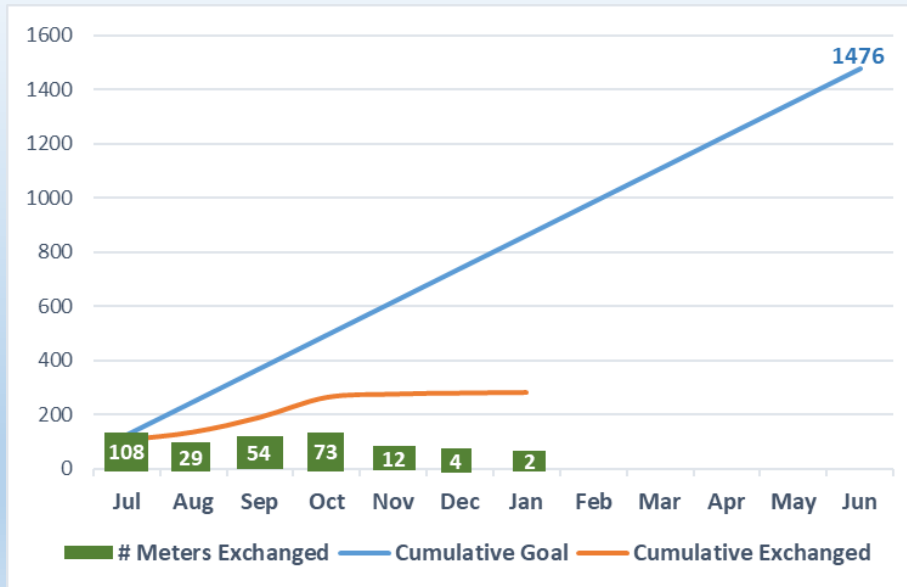

## Water System Regulatory Compliance

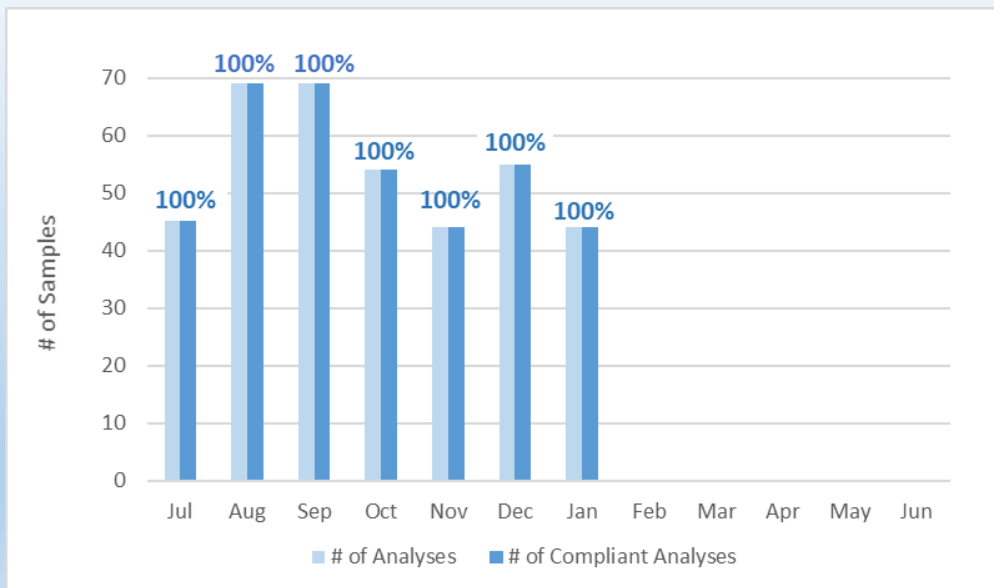

## Water Preventative Maintenance Work Orders

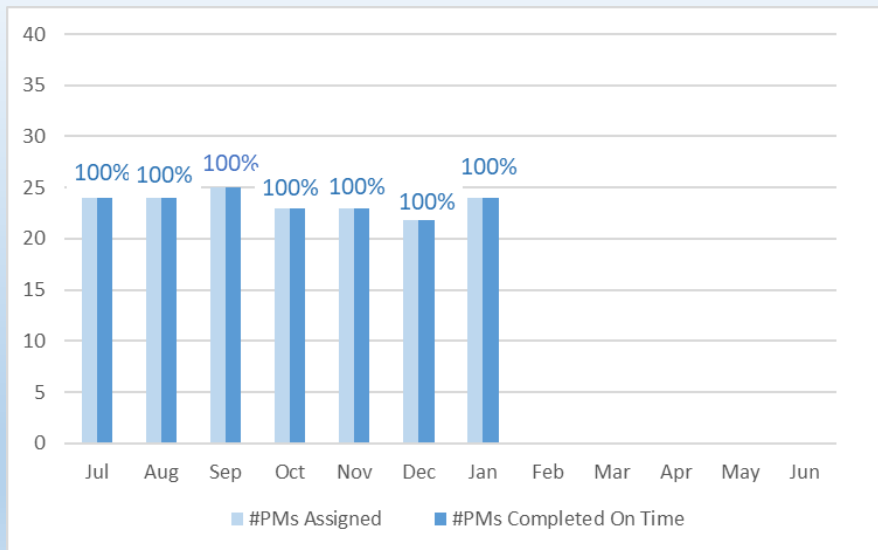

## Valve Exercise Program

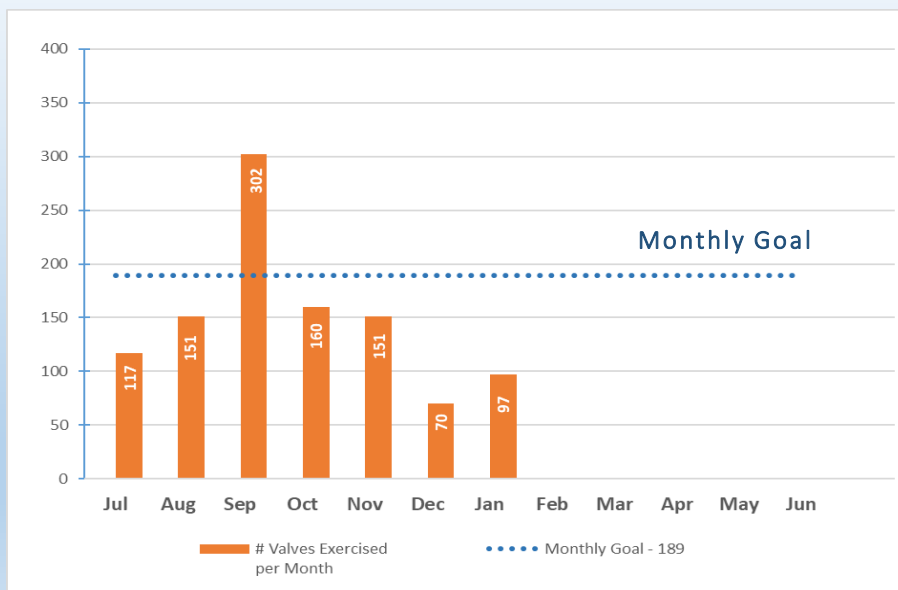

## Valves Replaced

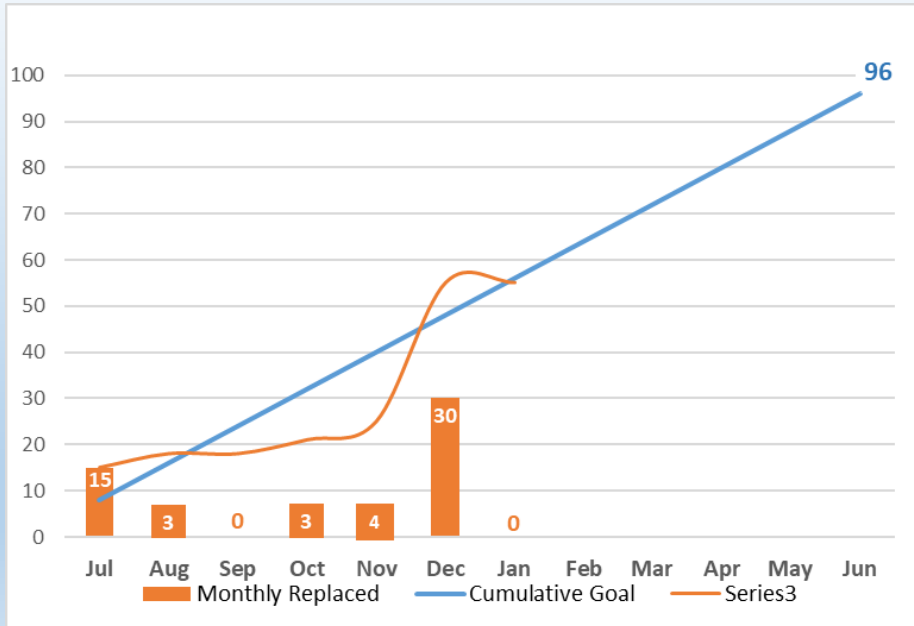

## Rolling Total Broken Valves

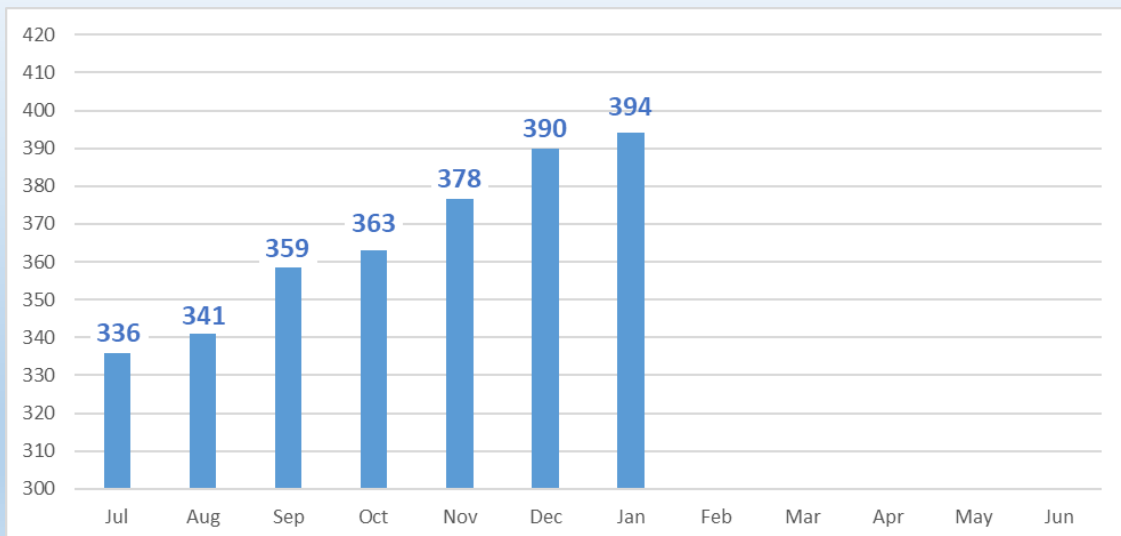

## Planned Outages > 4 Hours # of Customers Affected

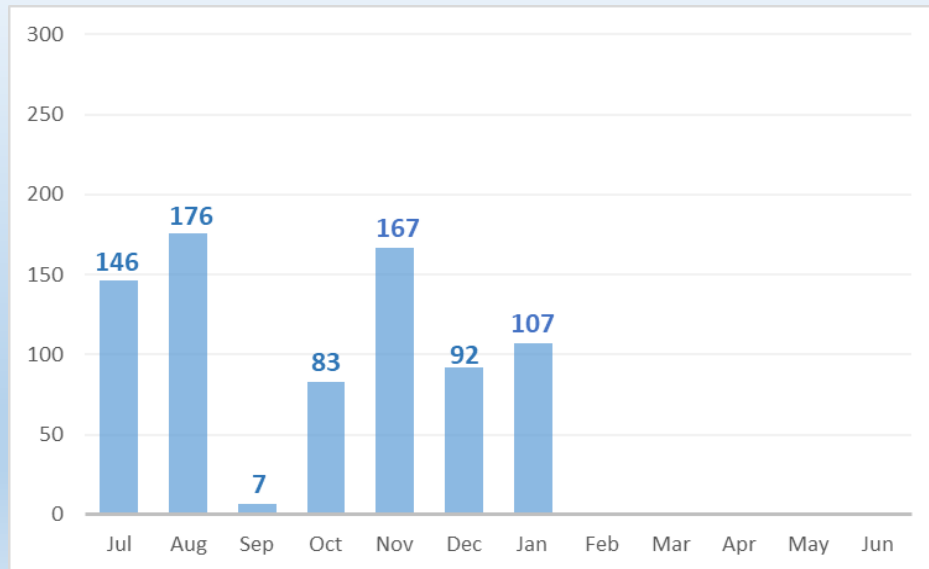

## Unplanned Disruption > 4 Hours # of Customers Affected

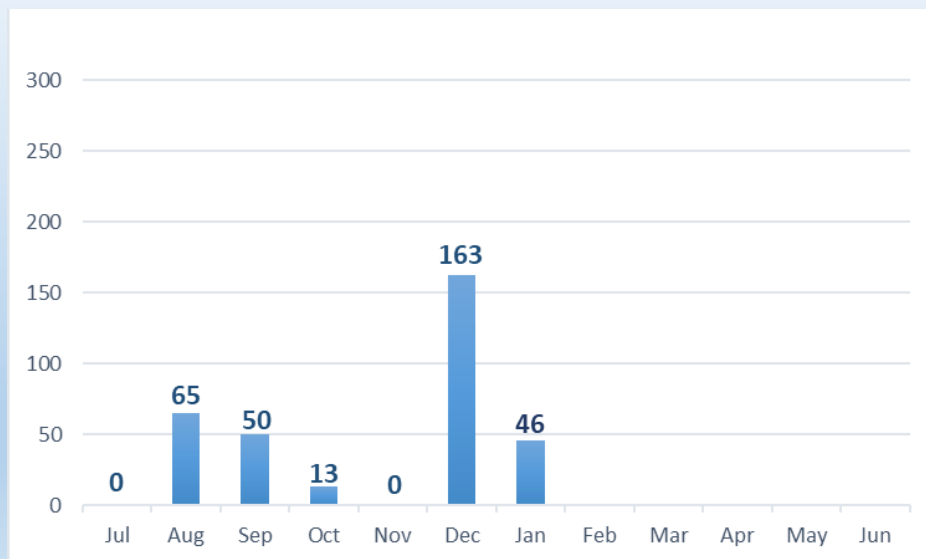



YOUR BEST PROTECTION

## ACWA JPIA

P. O. Box 619082  
Roseville, CA 95661-9082

phone  
916.786.5742  
800.231.5742

[www.acwajpia.com](http://www.acwajpia.com)

### President

E.G. "Jerry" Gladbach

### Vice President

Tom Cuquet

### Chief Executive Officer

Walter "Andy" Sells

### Executive Committee

Fred Bockmiller

Tom Cuquet

David Drake

E.G. "Jerry" Gladbach

Brent Hasty

Melody A. McDonald

Randall Reed

J. Bruce Rupp

Pamela Tobin

### Core Values

- People
- Service
- Integrity
- Innovation

January 13, 2021

Fallbrook Public Utility District (F002)  
990 E. Mission Rd.  
Fallbrook, CA 92028

### General Manager:

Each year at Fall Conference, the JPIA recognizes members that have a Loss Ratio of 20% or less in either of the Liability, Property, or Workers' Compensation programs (loss ratio = total losses / total premiums).

The members with this distinction receive the "**President's Special Recognition Award**" certificate for each Program that they qualify in.

The JPIA is extremely pleased to present Fallbrook Public Utility District (F002) with this special recognition and commends the District on the hard work in reducing claims.

Congratulations to you, your staff, Board, and District. Keep up the good work!

The JPIA wishes you the best in 2021.

Sincerely,

E.G. "Jerry" Gladbach  
President

Enclosure: President's Special Recognition Award(s)

# *President's Special Recognition Award*

*The President of the  
ACWA JPIA  
hereby gives Special Recognition to*

## *Fallbrook Public Utility District*

*for achieving a low ratio of "Paid Claims and Case Reserves" to "Deposit Premiums"  
in the Property Program for the period 04/01/2016 - 03/31/2019  
announced at the Board of Directors' Meeting in a Virtual Meeting.*

*E. G. "Jerry" Gladbach*

*E. G. "Jerry" Gladbach, President*



*December 15, 2020*

## M E M O

**TO:** Board of Directors  
**FROM:** David Shank, Assistant General Manager/CFO  
**DATE:** February 22, 2021  
**SUBJECT:** Financial Summary Report – January

---

### Purpose

Provide an overview of changes in the District's financial position.

### Summary

The graph below shows the District's year-to-date Revenues, Expenditures and Net revenues.

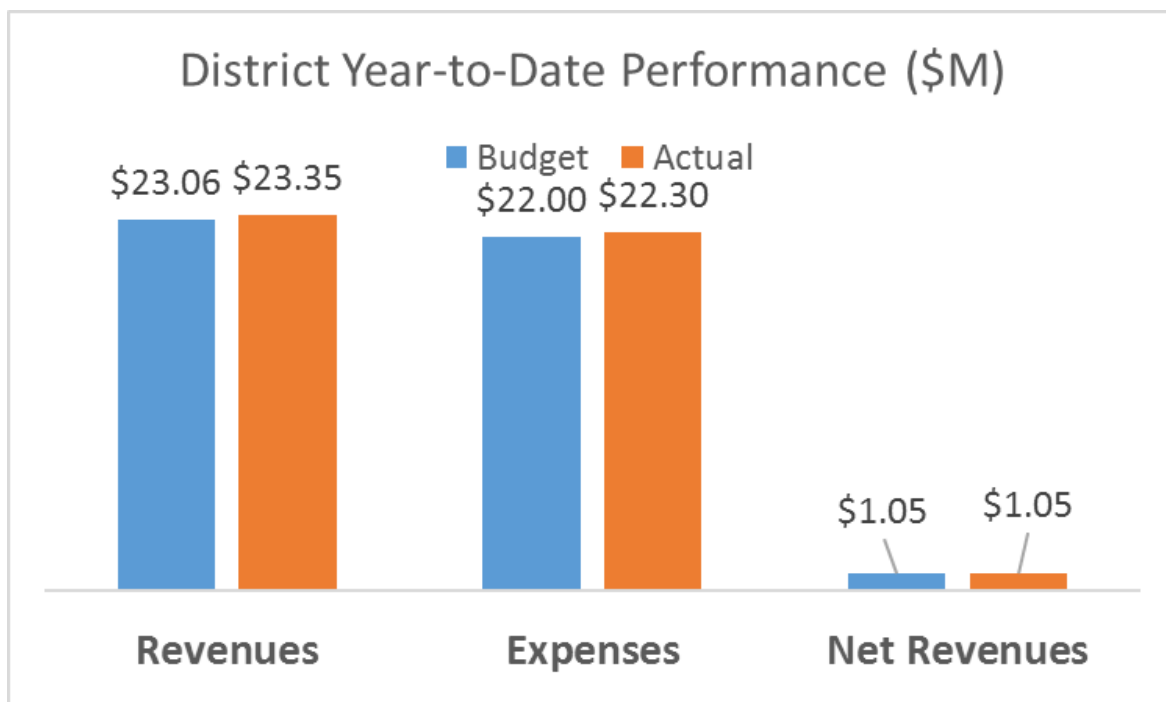

The results are tracking very close to the District's Budget. These results include the prepayment of \$1.75 million in debt, which was part of the debt refunding executed in January. The overall financial performance, after adjusting for expected State reimbursement, is in line with the Budget. The District's financial performance is expected to outperform the Budget levels given the debt service prepayment.

The graph below shows the District's bank holdings reported in the Treasurer's Report at the end of the current and prior month.



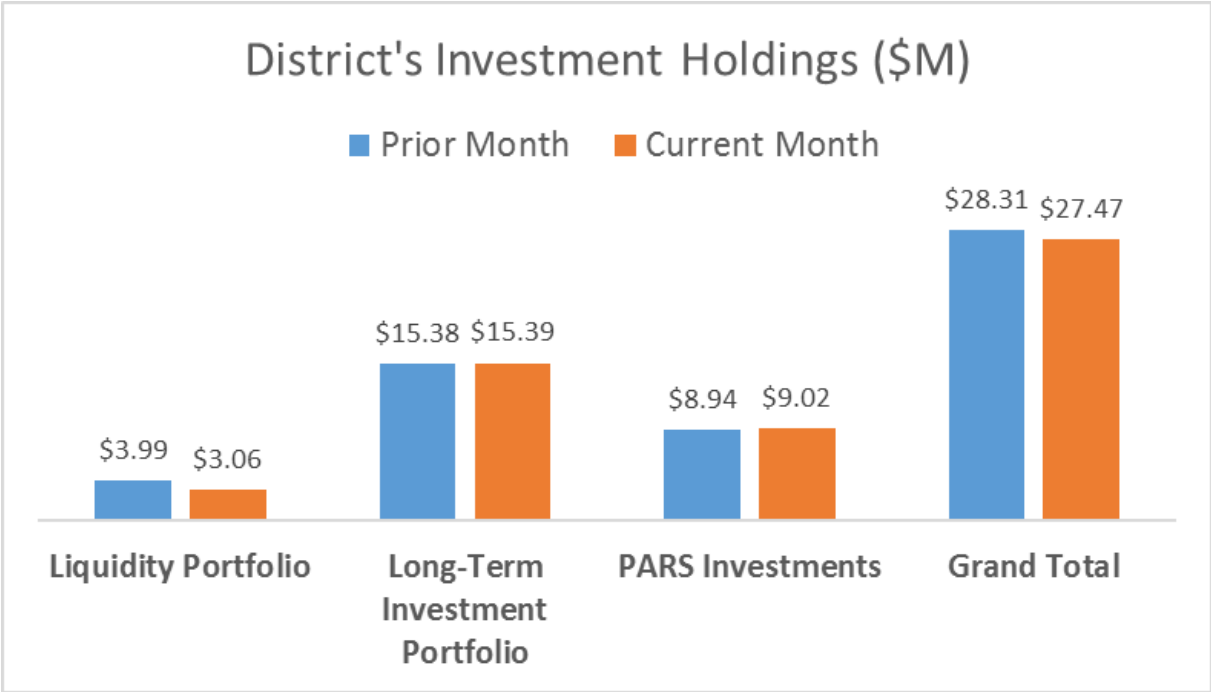

Overall, the District's financial position decreased this month with \$0.8 million less held in District accounts at month end. Operating activities related to the debt refunding drove the decrease in funds. No District funds were required this month to fund expenditures related to the Santa Margarita Conjunctive Use Project this month. The District transferred \$100,000 of the Budgeted \$500,000 to the PARS Trust this month. Overall these investments continue to perform in line with the equity markets.

Recommended Action

This item is for discussion only. No action is required.

**M E M O**

**TO:** Board of Directors  
**FROM:** David Shank, Assistant General Manager/CFO  
**DATE:** February 22, 2021  
**SUBJECT:** Treasurer's Report

---

Purpose

Provide the January, 2021 Treasurer's Report. Confirm that the District's investment portfolio is in compliance with the Investment Policy and that the District is able to meet the expenditure requirements for the next 6-months.

Notes

The State's reimbursements for the Santa Margarita Conjunctive Use Project Treatment Plant remain current as shown by the flat LAIF Account month end balances. The District continues to carefully manage its working capital to ensure its ability to meet its financial commitments. The draw on the Money Market account reflects normal operations and the \$1.75 million prepayment made on the State Revolving Loan as part of the debt refunding that was executed in January.

Summary

**Treasurer's Report January 31, 2021**

<b>Account</b>	<b>Beginning Balance</b>	<b>Ending Balance</b>
Operating Fund	\$ 19,634	\$ 19,525
Money Market	\$ 2,159,978	\$ 1,226,475
CAMP Account	\$ 1,814,680	\$ 1,814,864
<b><i>District's Liquidity Portfolio</i></b>	<b>\$ 3,994,292</b>	<b>\$ 3,060,864</b>
PFM Managed Long-term Investment Portfolio*	\$ 11,275,918	\$ 11,283,232
LAIF (Long-term Reserves)	\$ 4,100,337	\$ 4,106,394
PARS (OPEB & Pension Trust)**	\$ 8,940,899	\$ 9,021,606
<b><i>District Accounts Total</i></b>	<b>\$ 28,311,446</b>	<b>\$ 27,472,096</b>

\*\$6.21M of funds are from the sale of the Santa Margarita properties.

\*\*\$3.78M of funds are from the sale of the Santa Margarita Properties.



Dave Shank  
February 22, 2021



## Fallbrook Public Utilities District - Holdings Summary

Security Type	December 31, 2020	January 31, 2021	Change (\$)	Change (%)
U.S. Treasury	\$5,842,300.88	\$5,834,952.30	(\$7,348.58)	-0.1%
Municipal	\$171,069.30	\$170,741.20	(\$328.10)	-0.2%
Federal Agency CMO	\$112,950.57	\$112,941.24	(\$9.33)	0.0%
Corporate Note	\$3,379,172.34	\$3,374,736.71	(\$4,435.63)	-0.1%
Asset-Backed Security	\$703,856.62	\$695,045.31	(\$8,811.31)	-1.3%
<b>Securities Total</b>	<b>\$10,209,349.71</b>	<b>\$10,188,416.76</b>	<b>(\$20,932.95)</b>	<b>-0.2%</b>
Money Market Fund	\$1,066,568.23	\$1,094,815.72	\$28,247.49	2.6%
<b>Total Investments</b>	<b>\$11,275,917.94</b>	<b>\$11,283,232.48</b>	<b>\$7,314.54</b>	<b>0.1%</b>

### Summary

FY 20-21 Accrual Earnings	\$132,785.42
Yield to Maturity at Cost	2.21%
Weighted Average Maturity (Years)	1.66

### Maturity Distribution

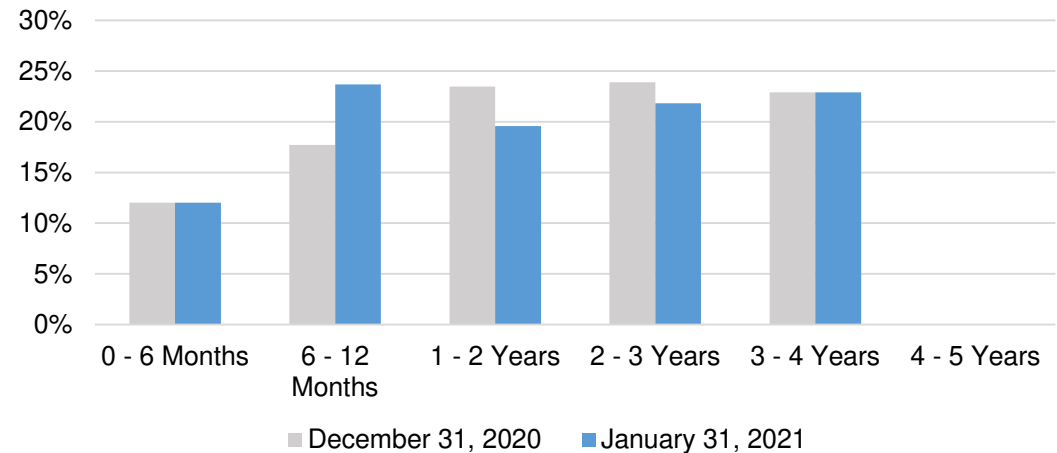

Security market values, excluding accrued interest, as on last day of month.

**FALLBROOK PUBLIC UTILITY DISTRICT  
PARS Post-Employment Benefits Trust**

**Account Report for the Period  
1/1/2021 to 1/31/2021**

David Shank  
Assistant General Manager/CFO  
Fallbrook Public Utility District  
990 East Mission Road  
Fallbrook, CA 92028

## Account Summary

Source	Balance as of 1/1/2021	Contributions	Earnings	Expenses	Distributions	Transfers	Balance as of 1/31/2021
OPEB	\$1,184,704.15	\$0.00	-\$2,299.70	\$246.81	\$0.00	\$0.00	\$1,182,157.64
PENSION	\$7,756,194.89	\$100,000.00	-\$15,131.06	\$1,615.88	\$0.00	\$0.00	\$7,839,447.95
<b>Totals</b>	<b>\$8,940,899.04</b>	<b>\$100,000.00</b>	<b>-\$17,430.76</b>	<b>\$1,862.69</b>	<b>\$0.00</b>	<b>\$0.00</b>	<b>\$9,021,605.59</b>

## Investment Selection

**Source**

OPEB	Moderate HighMark PLUS
PENSION	Moderate HighMark PLUS

## Investment Objective

**Source**

OPEB	The dual goals of the Moderate Strategy are growth of principal and income. It is expected that dividend and interest income will comprise a significant portion of total return, although growth through capital appreciation is equally important. The portfolio will be allocated between equity and fixed income investments.
PENSION	The dual goals of the Moderate Strategy are growth of principal and income. It is expected that dividend and interest income will comprise a significant portion of total return, although growth through capital appreciation is equally important. The portfolio will be allocated between equity and fixed income investments.

## Investment Return

Source	1-Month	3-Months	1-Year	Annualized Return			Plan's Inception Date
				3-Years	5-Years	10-Years	
OPEB	-0.19%	9.95%	11.93%	7.31%	-	-	2/16/2017
PENSION	-0.19%	9.95%	11.90%	7.23%	-	-	2/16/2017

Information as provided by US Bank, Trustee for PARS; Not FDIC Insured; No Bank Guarantee; May Lose Value

Past performance does not guarantee future results. Performance returns may not reflect the deduction of applicable fees, which could reduce returns. Information is deemed reliable but may be subject to change.  
Investment Return: Annualized rate of return is the return on an investment over a period other than one year multiplied or divided to give a comparable one-year return.  
Account balances are inclusive of Trust Administration, Trustee and Investment Management fees

California State Treasurer  
**Fiona Ma, CPA**



Local Agency Investment Fund  
 P.O. Box 942809  
 Sacramento, CA 94209-0001  
 (916) 653-3001

February 10, 2021

[LAIF Home](#)  
[PMIA Average Monthly Yields](#)

FALLBROOK PUBLIC UTILITY DISTRICT

TREASURER  
 P.O. BOX 2290  
 FALLBROOK, CA 92088

[Tran Type Definitions](#)

**Account Number:** 85-37-001

January 2021 Statement

Effective Date	Transaction Date	Tran Type	Confirm Number	Web Confirm Number	Authorized Caller	Amount
1/15/2021	1/14/2021	QRD	1664928	N/A	SYSTEM	6,056.96

**Account Summary**

Total Deposit:	6,056.96	Beginning Balance:	4,100,337.47
Total Withdrawal:	0.00	Ending Balance:	4,106,394.43



Account Statement - Transaction Summary

For the Month Ending January 31, 2021

Fallbrook Public Utility District - Liquidity - 6050-004

CAMP Pool	
Opening Market Value	1,814,679.71
Purchases	184.07
Redemptions	0.00
Unsettled Trades	0.00
Change in Value	0.00
<b>Closing Market Value</b>	<b>\$1,814,863.78</b>
Cash Dividends and Income	184.07

Asset Summary	January 31, 2021	December 31, 2020
<b>CAMP Pool</b>	1,814,863.78	1,814,679.71
<b>Total</b>	<b>\$1,814,863.78</b>	<b>\$1,814,679.71</b>

Asset Allocation	
CAMP Pool	100.00%



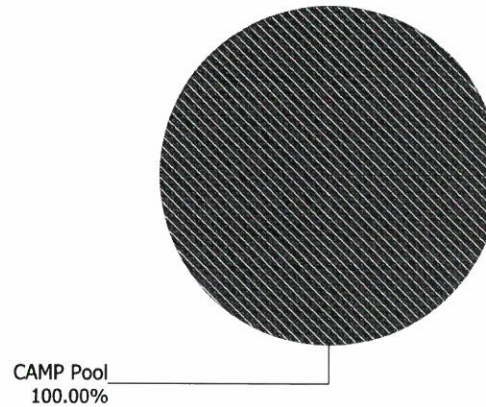

**Account Statement**

For the Month Ending **January 31, 2021**

Fallbrook Public Utility District - Liquidity - 6050-004

Trade Date	Settlement Date	Transaction Description	Share or Unit Price	Dollar Amount of Transaction	Total Shares Owned
<b>CAMP Pool</b>					
<b>Opening Balance</b>					<b>1,814,679.71</b>
01/29/21	02/01/21	Accrual Income Div Reinvestment - Distributions	1.00	184.07	1,814,863.78
<b>Closing Balance</b>					<b>1,814,863.78</b>

	Month of January	Fiscal YTD July-January		
<b>Opening Balance</b>	1,814,679.71	2,562,568.92	<b>Closing Balance</b>	1,814,863.78
<b>Purchases</b>	184.07	802,294.86	<b>Average Monthly Balance</b>	1,814,697.52
<b>Redemptions (Excl. Checks)</b>	0.00	(1,550,000.00)	<b>Monthly Distribution Yield</b>	0.12%
<b>Check Disbursements</b>	0.00	0.00		
<b>Closing Balance</b>	<b>1,814,863.78</b>	<b>1,814,863.78</b>		
<b>Cash Dividends and Income</b>	184.07	2,294.86		



Managed Account Security Transactions & Interest

For the Month Ending January 31, 2021

FPUD - INVESTMENT PORTFOLIO - 28710100

Transaction Type	Trade	Settle	Security Description	CUSIP	Par	Principal Proceeds	Accrued Interest	Total	Realized G/L Cost	Realized G/L Amort Cost	Sale Method
<b>INTEREST</b>											
	01/01/21	01/25/21	FHLMC SERIES K721 A2 DTD 12/01/2015 3.090% 08/01/2022	3137BM6P6	110,000.00	0.00	283.25	283.25			
	01/04/21	01/04/21	MONEY MARKET FUND	MONEY0002	0.00	0.00	8.99	8.99			
	01/15/21	01/15/21	MBALT 2019-B A3 DTD 11/20/2019 2.000% 10/17/2022	58769QAC5	60,000.00	0.00	100.00	100.00			
	01/15/21	01/15/21	COMET 2019-A2 A2 DTD 09/05/2019 1.720% 08/15/2024	14041NFU0	285,000.00	0.00	408.50	408.50			
	01/15/21	01/15/21	JDOT 2018-A A3 DTD 02/28/2018 2.660% 04/15/2022	47788CAC6	4,330.58	0.00	9.60	9.60			
	01/15/21	01/15/21	HAROT 2018-1 A3 DTD 02/28/2018 2.640% 02/15/2022	43814UAC3	24,716.82	0.00	54.38	54.38			
	01/15/21	01/15/21	COPAR 2019-1 A3 DTD 05/30/2019 2.510% 11/15/2023	14042WAC4	40,000.00	0.00	83.67	83.67			
	01/15/21	01/15/21	DCENT 2019-A3 A DTD 10/31/2019 1.890% 10/15/2024	254683CM5	120,000.00	0.00	189.00	189.00			
	01/15/21	01/15/21	JDOT 2019-B A3 DTD 07/24/2019 2.210% 12/15/2023	477870AC3	30,000.00	0.00	55.25	55.25			
	01/16/21	01/16/21	GM FINANCIAL SECURITIZED TERM DTD 07/24/2019 2.180% 04/16/2024	36257PAD0	50,000.00	0.00	90.83	90.83			
	01/21/21	01/21/21	HAROT 2019-2 A3 DTD 05/29/2019 2.520% 06/21/2023	43815MAC0	75,000.00	0.00	157.50	157.50			
	01/24/21	01/24/21	BANK OF AMERICA CORP CORP NOTES DTD 01/24/2012 5.700% 01/24/2022	06051GEM7	130,000.00	0.00	3,705.00	3,705.00			
	01/29/21	01/29/21	BANK OF NY MELLON CORP NOTE DTD 01/29/2018 2.950% 01/29/2023	06406RAE7	200,000.00	0.00	2,950.00	2,950.00			
	01/30/21	01/30/21	US BANCORP DTD 07/29/2019 2.400% 07/30/2024	91159HHX1	145,000.00	0.00	1,740.00	1,740.00			
	01/31/21	01/31/21	US TREASURY NOTES DTD 02/02/2015 1.500% 01/31/2022	912828H86	460,000.00	0.00	3,450.00	3,450.00			
	01/31/21	01/31/21	US TREASURY NOTES DTD 07/31/2017 1.875% 07/31/2022	9128282P4	440,000.00	0.00	4,125.00	4,125.00			
	01/31/21	01/31/21	US TREASURY NOTES DTD 07/31/2019 1.750% 07/31/2024	912828Y87	200,000.00	0.00	1,750.00	1,750.00			





**Managed Account Security Transactions & Interest**

For the Month Ending **January 31, 2021**

**FPUD - INVESTMENT PORTFOLIO - 28710100**

Transaction Type		Security Description	CUSIP	Par	Principal Proceeds	Accrued Interest	Total	Realized G/L Cost	Realized G/L Amort Cost	Sale Method
Trade	Settle									
<b>INTEREST</b>										
01/31/21	01/31/21	US TREASURY NOTES DTD 08/01/2016 1.125% 07/31/2021	912828S76	175,000.00	0.00	984.38	984.38			
<b>Transaction Type Sub-Total</b>				<b>2,549,047.40</b>	<b>0.00</b>	<b>20,145.35</b>	<b>20,145.35</b>			
<b>PAYDOWNS</b>										
01/15/21	01/15/21	COPAR 2019-1 A3 DTD 05/30/2019 2.510% 11/15/2023	14042WAC4	1,053.73	1,053.73	0.00	1,053.73	0.21	0.00	
01/15/21	01/15/21	JDOT 2018-A A3 DTD 02/28/2018 2.660% 04/15/2022	47788CAC6	1,690.44	1,690.44	0.00	1,690.44	0.12	0.00	
01/15/21	01/15/21	HAROT 2018-1 A3 DTD 02/28/2018 2.640% 02/15/2022	43814UAC3	5,357.97	5,357.97	0.00	5,357.97	0.69	0.00	
<b>Transaction Type Sub-Total</b>				<b>8,102.14</b>	<b>8,102.14</b>	<b>0.00</b>	<b>8,102.14</b>	<b>1.02</b>	<b>0.00</b>	
<b>Managed Account Sub-Total</b>					<b>8,102.14</b>	<b>20,145.35</b>	<b>28,247.49</b>	<b>1.02</b>	<b>0.00</b>	
<b>Total Security Transactions</b>					<b>\$8,102.14</b>	<b>\$20,145.35</b>	<b>\$28,247.49</b>	<b>\$1.02</b>	<b>\$0.00</b>	



## M E M O

**TO:** Board of Directors  
**FROM:** David Shank, Assistant General Manager/CFO  
**DATE:** February 22, 2021  
**SUBJECT:** Budget Status Report for Fiscal Year 2020-2021

---

### Purpose

Provide a Budget Status Report (BSR) to the Board.

### Summary

The BSR shows the District's financial performance compared to the budget for the month of January, Year-to-Date and the annual budgeted amount. This report shows the District first quarter of financial results.

Total revenues year-to-date are above budget by 1.3%, which is largely due to property tax receipts from the County and improved water sales. Water sales have improved over the past few months with water sales revenues now 3.3% over budget. Water sales, which as shown in the monthly water sales chart below, are now 3.5% over budget. Lower than Budgeted revenues were received by both the Wastewater and Recycled Water Services. While these numbers are below budget levels, they remain stable and are closer to budget than last year at this time.

Non-operating revenues are over budget driven by County property tax, Capacity charge revenues, portfolio interest and other revenues. Total non-operating revenues are expected to trend towards budget over the remainder of the year as interest earnings fall and the impact of one time other revenues diminishes.

The District's year-to-date total expenditures are under budget due to the lower than budgeted operating expenses. Vacant positions and non-operating expenditures below budget are driving this trend. Purchased water expense is slightly over budget as a result of higher water sales. The District also made a prepayment on the WWTP SRF Loan as part of its refunding as shown in the Report.

Total revenue is \$23,346,913 or 1.3% over budget and total expenditures are \$18,348,264 or 5.8% under budget. PAYGO CIP expenditures are 7.2% under budget but are expected to trend towards Budget levels. After adjusting for expected State Loan proceeds, the District's financial results are in line with the Budget.

### Recommended Action

This item is for discussion only. No action is required.

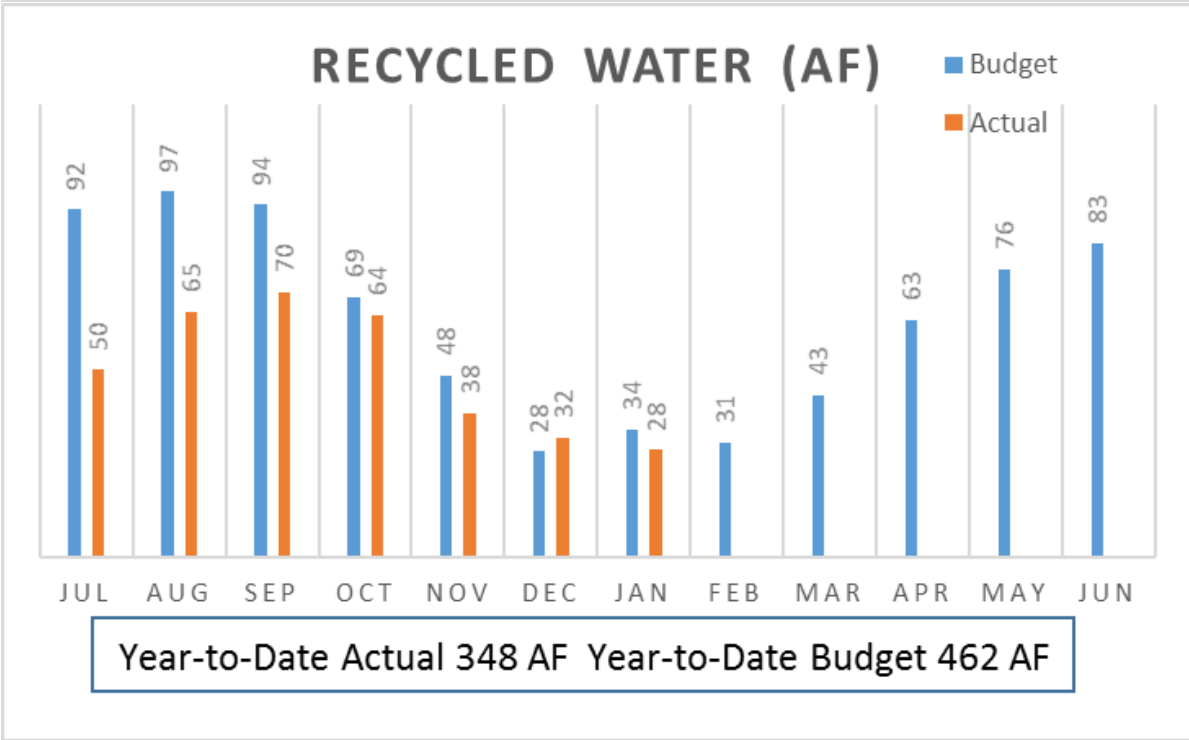
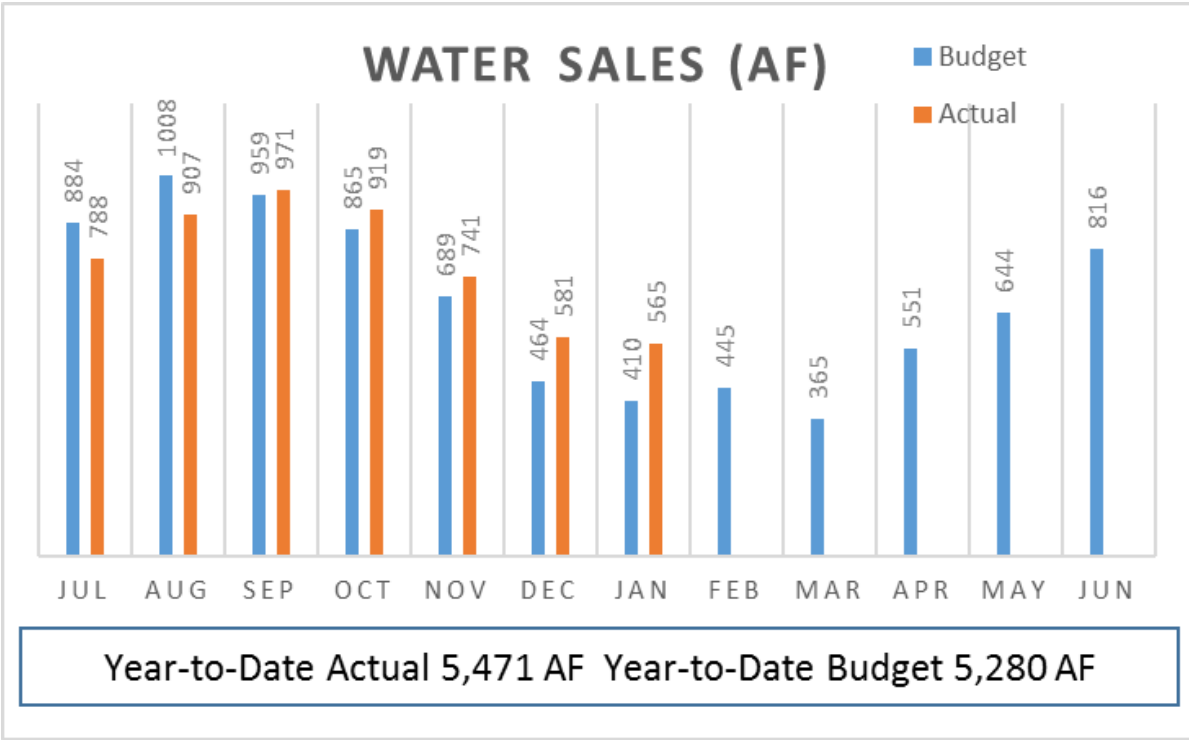

## Monthly Budget Report for January

Favorable Variance Shown as a positive number

	Current Month		Year-To-Date				Annual Budget		
	Actual	Budget	Actual	Budget	Variance	%	Budget	Remaining Balance	%
<b>Operating Revenues:</b>								Year remaining	41.7%
Water Sales	1,232,494	970,430	11,479,610	11,116,542	363,068	3.3%	17,660,076	6,180,467	35.0%
Water Meter Service Charges	631,186	653,171	4,261,713	4,281,898	(20,184)	-0.5%	7,547,752	3,286,039	43.5%
Wastewater Service Charges	482,215	486,537	3,561,923	3,753,645	(191,722)	-5.1%	6,186,330	2,624,407	42.4%
Recycled Water Revenues	57,011	58,190	639,299	699,279	(59,980)	-8.6%	1,188,242	548,943	46.2%
Other Operating Revenue	-	917	-	6,417	(6,417)	-100.0%	11,000	11,000	100.0%
Total Operating Revenue	2,402,906	2,169,245	19,942,545	19,857,780	84,765	0.4%	32,593,400	12,650,855	38.8%
<b>Non Operating Revenues:</b>									
Water Capital Improvement Charge	118,847	121,273	815,792	848,914	(33,122)	-3.9%	1,455,281	639,489	43.9%
Wastewater Capital Improvement Charge	98,037	100,594	685,735	704,160	(18,425)	-2.6%	1,207,132	521,397	43.2%
Property Taxes	323,896	44,847	1,266,506	1,175,447	91,059	7.7%	2,022,485	755,979	37.4%
Water Standby/Availability Charge	63,947	4,616	114,927	117,523	(2,596)	-2.2%	204,000	89,073	43.7%
Water/Wastewater Capacity Charges	5,778	7,083	72,645	49,583	23,062	46.5%	85,000	12,355	14.5%
Portfolio Interest	14,348	11,792	145,732	82,542	63,190	76.6%	141,500	(4,232)	-3.0%
Pumping Capital Improvement Charge	1,333	2,730	14,659	19,108	(4,448)	-23.3%	32,756	18,097	55.2%
Federal Interest Rate Subsidy	57,690	-	57,690	56,445	1,245	2.2%	110,677	52,986	47.9%
Facility Rents	18,179	18,333	127,536	128,333	(797)	-0.6%	220,000	92,464	42.0%
Other Non-Operating Revenues	13,405	2,500	103,146	17,500	85,646	489.4%	30,000	(73,146)	-243.8%
Total Non Operating Revenues	715,460	313,769	3,404,368	3,199,555	204,813	6.4%	5,508,830	2,104,462	38.2%
<b>Total Revenues</b>	<b>3,118,365</b>	<b>2,483,013</b>	<b>23,346,913</b>	<b>23,057,335</b>	<b>289,578</b>	<b>1.3%</b>	<b>38,102,230</b>	<b>14,755,317</b>	<b>38.7%</b>
<b>Expenditures</b>									
Purchased Water Expense	897,736	852,040	8,655,745	8,811,900	156,155	1.8%	14,012,905	5,357,160	38.2%
Water Services*	218,951	245,871	1,559,128	1,966,971	407,843	20.7%	3,196,328	1,637,200	51.2%
Wastewater Services*	235,208	250,104	1,757,844	2,000,830	242,985	12.1%	3,251,348	1,493,504	45.9%
Recycled Water Services*	31,459	41,884	212,749	335,073	122,324	36.5%	544,494	331,745	60.9%
Administrative Services*	482,569	497,336	3,754,181	3,978,686	224,505	5.6%	6,465,365	2,711,184	41.9%
Total Operating Expenses	1,865,922	1,887,235	15,939,648	17,093,460	1,153,812	6.8%	27,470,440	11,530,792	42.0%
<b>Debt Service Expenses</b>									
SMCUP SRF	-	-	-	-	-	NA	800,810	800,810	100.0%
Red Mountain SRF	197,925	197,926	395,850	395,851	0	0.0%	395,851	0	0.0%
WWTP SRF	1,750,772	-	1,750,772	-	(1,750,772)	NA	1,845,746	94,974	5.1%
WW Rev Refunding Bonds**	-	-	-	-	-	NA	-	-	#DIV/0!
QECB Solar Debt	-	-	261,993	261,993	-	0.0%	520,642	258,649	49.7%
Total Debt Service	1,948,697	197,926	2,408,616	657,844	(1,750,772)	-266.1%	3,563,048	1,154,433	32.4%
<b>Total Expenses</b>	<b>3,814,619</b>	<b>2,085,161</b>	<b>18,348,264</b>	<b>17,751,304</b>	<b>(596,960)</b>	<b>-3.4%</b>	<b>31,033,488</b>	<b>12,685,225</b>	<b>40.9%</b>
<b>Net Revenue/(loss) From Operations and Debt Service</b>	<b>(696,254)</b>	<b>397,852</b>	<b>4,998,649</b>	<b>5,306,032</b>	<b>(307,382)</b>	<b>-5.8%</b>	<b>7,068,741</b>	<b>2,070,092</b>	<b>29.3%</b>
<b>Capital Investment</b>									
<b>Capital Investment</b>									
Construction Expenditures	238,778	542,500	3,948,331	4,252,500	304,169	7.2%	7,221,750	3,273,419	45.3%
SMCUP Expenditures***	2,145,236	2,226,889	21,578,375	22,632,191	1,053,816	4.7%	31,900,000	10,321,625	32.4%
SRF Loan Proceeds Draw (Capital Project Funds)****	(2,145,236)	(2,226,889)	(21,578,375)	(22,632,191)	(1,053,816)	4.7%	(31,900,000)	(10,321,625)	32.4%
<b>Net Revenue/(Loss)</b>	<b>(935,032)</b>	<b>(144,648)</b>	<b>1,050,318</b>	<b>1,053,532</b>	<b>(3,213)</b>	<b>-0.3%</b>	<b>(153,009)</b>	<b>(1,203,327)</b>	<b>786.4%</b>

\*Includes share of \$100,000 PARS transfer.

\*\*Cost of issuance paid from proceeds and not included in statement

\*\*\*CIP expenditures related to the SMCUP have been updated based upon contractor draw scheduled and are funded by SRF Loan proceeds.

\*\*\*\*YTD Actual amount adjusted to reflect expected State Reimbursement for reporting purposes.

01/31/2021

Treasurer's Warrant No. January

TO: Treasurer of the Fallbrook Public Utility District

The bills and claims listed below are approved as authorized by resolution no. 3538 of the Board of Directors dated July 8, 1985. You are hereby authorized and directed to pay said prospective claims for the amounts stated (less discounts in instances where discounts are allowed).

## Payroll -01/2021

### Computer Check Register

Payroll #1	\$138,469.65
Payroll #2	<u>\$140,028.40</u>
	<u>\$278,498.05</u>

# Accounts Payable

## Checks by Date - Summary by Check Date

User: annaleceb  
Printed: 2/2/2021 1:16 PM

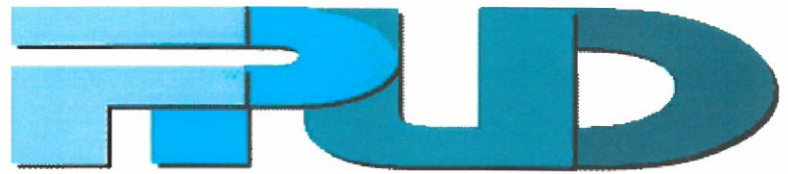

### Fallbrook Public Utility District

Purchasing Dept. Phone: (760) 728-1151, Fax: (760) 728-8491

Main Office Phone: (760) 728-1125, Fax: (760) 728-6029

Check No	Vendor No	Vendor Name	Check Date	Check Amount
85158	01460	AFLAC	01/07/2021	857.64
85159	91587	ALCO COVERS, LLC	01/07/2021	627.04
85160	91286	AMAZON CAPITAL SERVICES, INC.	01/07/2021	552.74
85161	91490	AMAZON WEB SERVICES, INC.	01/07/2021	1,118.92
85162	05778	AQUATIC BIOASSAY AND CONSULTIN	01/07/2021	1,350.00
85163	02805	ASBURY ENVIRONMENTAL SERVICES	01/07/2021	227.80
85164	05088	AT&T	01/07/2021	828.56
85165	06020	BABCOCK LABORATORIES, INC	01/07/2021	1,810.00
85166	UB*00370	KYLE & HEATHER BISSONNETTE	01/07/2021	126.82
85167	03134	CALIFORNIA WATER ENVIRONMENT.	01/07/2021	192.00
85168	03978	CAMERON WELDING SUPPLY	01/07/2021	582.43
85169	06115	CDW GOVERNMENT INC.	01/07/2021	6,448.41
85170	03205	CITY OF OCEANSIDE	01/07/2021	279.80
85171	91272	KEVIN COLLINS	01/07/2021	60.00
85172	05192	DIAMOND ENVIRONMENTAL SERVIC	01/07/2021	350.65
85173	06711	ECS IMAGING, INC	01/07/2021	3,850.00
85174	03391	ELECTRICAL SALES INC	01/07/2021	198.76
85175	06303	EXECUTIVE LANDSCAPE INC.	01/07/2021	199.38
85176	00169	FALLBROOK OIL COMPANY	01/07/2021	5,041.26
85177	04494	FEDERAL EXPRESS CORPORATION	01/07/2021	338.33
85178	01432	FERGUSON WATERWORKS #1083	01/07/2021	8,440.49
85179	91540	FIRST BANKCARD	01/07/2021	4,906.00
85180	02170	GRAINGER, INC.	01/07/2021	478.45
85181	UB*00371	CHRIS GRANT	01/07/2021	0.90
85182	06577	INFOSEND INC	01/07/2021	2,296.12
85183	00190	JCI JONES CHEMICALS INC.	01/07/2021	3,366.78
85184	91304	LEARNSOFT CONSULTING INC	01/07/2021	255.00
85185	91130	LINCOLN NATIONAL LIFE INSURANC	01/07/2021	3,201.18
85186	90887	LLOYD PEST CONTROL	01/07/2021	80.00
85187	91219	METAL & CABLE, INC.	01/07/2021	3,706.41
85188	91192	MISSION LINEN SUPPLY	01/07/2021	1,693.71
85189	06024	MATTHEW MORGAN	01/07/2021	142.49
85190	03201	NATIONAL SAFETY COMPLIANCE INC	01/07/2021	45.00
85191	06298	ONESOURCE DISTRIBUTORS, LLC	01/07/2021	3,616.78
85192	01267	PACIFIC PIPELINE	01/07/2021	21,094.63
85193	04900	PARADISE CHEVROLET CADILLAC	01/07/2021	277.20
85194	00215	PETTY CASH	01/07/2021	113.33
85195	91007	PFM ASSET MANGEMENT LLC	01/07/2021	899.25
85196	00216	PINE TREE LUMBER	01/07/2021	15.62
85197	91599	RUSH TRUCK CENTERS OF CALIFORN	01/07/2021	1,126.38
85198	03231	SAN DIEGO COUNTY WATER AUTH	01/07/2021	14,165.00
85199	00232	SAN DIEGO GAS & ELECTRIC	01/07/2021	4,157.10
85200	00236	SCRAPPYS	01/07/2021	1,959.24
85201	90929	SOUTHWEST ANSWERING SERVICE, I	01/07/2021	947.99
85202	05415	STATE WATER RESOURCE CONTROL I	01/07/2021	105.00
85203	02206	STATE WATER RESOURCES CONTROL	01/07/2021	1,400.00
85204	02815	SWRCB ACCOUNTING OFFICE	01/07/2021	34,180.08

Check No	Vendor No	Vendor Name	Check Date	Check Amount
85205	91598	TCI BUSINESS CAPITAL	01/07/2021	6,716.64
85206	00724	UNDERGROUND SERVICE ALERT	01/07/2021	321.03
85207	04290	VILLAGE NEWS, INC.	01/07/2021	495.00
85208	06554	VOLVO CONSTRUCTION EQUIPMENT	01/07/2021	916.31
85209	06231	WESTERN WATER WORKS SUPPLY CC	01/07/2021	2,072.25
85210	04995	AMERICAN MESSAGING	01/07/2021	144.78
85211	02805	ASBURY ENVIRONMENTAL SERVICES	01/07/2021	778.81
85212	05192	DIAMOND ENVIRONMENTAL SERVIC	01/07/2021	225.90
85213	06380	JANI-KING OF CALIFORNIA, INC - SA	01/07/2021	2,995.24
85214	05065	JOHNSON CONTROLS SECURITY SOL	01/07/2021	570.68
85215	06338	MYTHOS TECHNOLOGY INC	01/07/2021	1,705.22
85216	04075	RAYNE WATER SYSTEMS	01/07/2021	165.00
85217	91082	TELETRAC, INC	01/07/2021	2,084.27
Total for 1/7/2021:				156,901.80
ACH	00152	FPUD EMPL ASSOCIATION	01/14/2021	24.50
ACH	06758	US TREASURY - PAYROLL TAXES	01/14/2021	4,064.54
ACH	06759	STATE OF CA - PR TAXES	01/14/2021	799.19
ACH	06760	STATE OF CA - SDI	01/14/2021	157.20
ACH	06761	LINCOLN FINANCIAL GROUP	01/14/2021	402.80
ACH	06763	PERS - PAYROLL	01/14/2021	2,108.99
ACH	00152	FPUD EMPL ASSOCIATION	01/14/2021	465.00
ACH	00718	NATIONWIDE RETIREMENT SOLUTIO	01/14/2021	3,375.00
ACH	06758	US TREASURY - PAYROLL TAXES	01/14/2021	51,099.26
ACH	06759	STATE OF CA - PR TAXES	01/14/2021	7,647.67
ACH	06760	STATE OF CA - SDI	01/14/2021	2,457.78
ACH	06761	LINCOLN FINANCIAL GROUP	01/14/2021	7,267.47
ACH	06763	PERS - PAYROLL	01/14/2021	40,333.81
ACH	91508	CALIFORNIA STATE DISBURSEMENT	01/14/2021	346.15
85219	00231	SAN DIEGO COUNTY WATER AUTH	01/14/2021	1,023,882.04
85220	91513	ALCHEMY CONSULTING GROUP	01/14/2021	7,500.00
85221	91550	AMERICAN BUSINESS BANK	01/14/2021	4,810.58
85222	91503	BACKGROUNDS ONLINE	01/14/2021	38.50
85223	91241	LISA CHAFFIN	01/14/2021	60.00
85224	02176	CORELOGIC SOLUTIONS, LLC	01/14/2021	225.00
85225	91596	CRIDER PUBLIC RELATIONS, INC.	01/14/2021	1,487.50
85226	02925	DATA NET SOLUTIONS	01/14/2021	626.00
85227	09523	FALLBROOK EQUIP RENTALS	01/14/2021	5,728.27
85228	00169	FALLBROOK OIL COMPANY	01/14/2021	3,213.02
85229	00170	FALLBROOK WASTE & RECYCLING	01/14/2021	838.81
85230	04494	FEDERAL EXPRESS CORPORATION	01/14/2021	286.31
85231	91200	FIRST BANKCARD	01/14/2021	271.76
85232	91202	FIRST BANKCARD	01/14/2021	230.04
85233	91313	FIRST BANKCARD	01/14/2021	2,911.50
85234	02972	FISHER SCIENTIFIC COMPANY LLC	01/14/2021	432.10
85235	00182	GLENNIE'S OFFICE PRODUCTS, INC	01/14/2021	106.88
85236	02170	GRAINGER, INC.	01/14/2021	193.13
85237	05380	HACH CO	01/14/2021	2,530.43
85238	91544	HAZEN AND SAWYER, D.P.C.	01/14/2021	8,470.25
85239	06577	INFOSEND INC	01/14/2021	1,008.80
85240	06267	J2 GLOBAL IRELAND LIMITED	01/14/2021	59.91
85241	04027	JOES HARDWARE	01/14/2021	1,077.73
85242	03299	KAMAN INDUSTRIAL TECHNOLOGIE	01/14/2021	312.37
85243	03944	MISSION RESOURCE CONSV DISTRIC	01/14/2021	89.00
85244	05942	MSDSOONLINE, INC	01/14/2021	1,498.00
85245	90932	NAPA AUTO PARTS	01/14/2021	168.85



Check No	Vendor No	Vendor Name	Check Date	Check Amount
85246	00370	NUTRIEN AG SOLUTIONS, INC.	01/14/2021	127.14
85247	06298	ONESOURCE DISTRIBUTORS, LLC	01/14/2021	5,027.79
85248	91522	PACIFIC HYDROTECH CORP	01/14/2021	91,400.14
85249	04900	PARADISE CHEVROLET CADILLAC	01/14/2021	44.02
85250	91538	PUDGIL & COMPANY	01/14/2021	5,000.00
85251	91546	QUADIENT FINANCE USA, INC.	01/14/2021	800.00
85252	00232	SAN DIEGO GAS & ELECTRIC	01/14/2021	52,917.62
85253	91223	STERLING ADMINISTRATION	01/14/2021	125.00
85254	91385	VERONICA TAMZIL	01/14/2021	60.00
85255	91598	TCI BUSINESS CAPITAL	01/14/2021	1,567.44
85256	00458	VERIZON WIRELESS	01/14/2021	1,919.12
85257	91284	WM CORPORATE SERVICES, INC	01/14/2021	1,536.52
85258	91286	AMAZON CAPITAL SERVICES, INC.	01/14/2021	24.06
85259	91600	CAL PACIFIC TRUCK CENTER, LLC	01/14/2021	4,292.43
85260	03134	CALIFORNIA WATER ENVIRONMENT	01/14/2021	192.00
85261	91595	CLIFTONLARSONALLEN LLP	01/14/2021	1,800.00
85262	05179	AARON COX	01/14/2021	525.00
85263	91592	ELEMENT MATERIALS TECHNOLOGY	01/14/2021	360.00
85264	06303	EXECUTIVE LANDSCAPE INC.	01/14/2021	770.00
85265	01099	FALLBROOK IRRIGATION INC	01/14/2021	42.42
85266	06286	GARDA CL WEST, INC.	01/14/2021	292.16
85267	04958	GOSCH FORD TEMECULA	01/14/2021	25.18
85268	91071	JACOB ROBINSON	01/14/2021	205.00
85269	02265	RUPE'S HYDRAULICS	01/14/2021	910.72
85270	91486	SATELLITE PHONE STORE	01/14/2021	66.82
85271	91094	SCADA INTEGRATIONS	01/14/2021	5,418.00
85272	91107	SPECTRUM BUSINESS	01/14/2021	127.15
85273	02927	TIM STERGER	01/14/2021	60.00
85274	91223	STERLING ADMINISTRATION	01/14/2021	800.00
85275	02797	STEVE STONE	01/14/2021	218.95
85276	91123	STREAMLINE	01/14/2021	550.00
85277	UB*00372	MICHAEL & PHILENE THOMAS	01/14/2021	645.43
Total for 1/14/2021:				1,366,456.25
85278	00805	ACWA/JOINT POWERS INS.	01/21/2021	29,888.27
85279	91286	AMAZON CAPITAL SERVICES, INC.	01/21/2021	178.36
85280	02743	BEST BEST & KRIEGER	01/21/2021	26,351.89
85281	03134	CALIFORNIA WATER ENVIRONMENT	01/21/2021	475.00
85282	01719	MICKEY M. CASE	01/21/2021	60.00
85283	05953	CORODATA RECORDS MANAGEMENT	01/21/2021	739.30
85284	06675	CORODATA SHREDDING, INC	01/21/2021	64.37
85285	02925	DATA NET SOLUTIONS	01/21/2021	176.77
85286	01099	FALLBROOK IRRIGATION INC	01/21/2021	210.08
85287	91225	FIRST BANKCARD	01/21/2021	559.00
85288	91108	FLEETCREW	01/21/2021	250.00
85289	00182	GLENNIE'S OFFICE PRODUCTS, INC	01/21/2021	260.14
85290	04958	GOSCH FORD TEMECULA	01/21/2021	318.49
85291	02170	GRAINGER, INC.	01/21/2021	519.07
85292	02767	GRANGETTO FARM & GARDEN SUPPI	01/21/2021	62.35
85293	05380	HACH CO	01/21/2021	391.29
85294	90897	JOSHUA HARGROVE	01/21/2021	95.27
85295	06577	INFOSEND INC	01/21/2021	1,362.32
85296	05871	ITRON INC	01/21/2021	963.14
85297	00370	NUTRIEN AG SOLUTIONS, INC.	01/21/2021	68.39
85298	91601	QUADIENT LEASING USA, INC	01/21/2021	2,522.86
85299	06717	RDO EQUIPMENT CO	01/21/2021	3,089.83

Check No	Vendor No	Vendor Name	Check Date	Check Amount
85300	00159	SUPERIOR READY MIX	01/21/2021	780.74
85301	91598	TCI BUSINESS CAPITAL	01/21/2021	3,358.32
85302	91574	TRUSSELL TECHNOLOGIES, INC.	01/21/2021	4,458.30
85303	06231	WESTERN WATER WORKS SUPPLY CC	01/21/2021	1,014.58
85304	91602	WIENHOFF DRUG TESTING	01/21/2021	225.00
Total for 1/21/2021:				78,443.13
ACH	00152	FPUD EMPL ASSOCIATION	01/28/2021	465.00
ACH	00718	NATIONWIDE RETIREMENT SOLUTIO	01/28/2021	3,375.00
ACH	06758	US TREASURY - PAYROLL TAXES	01/28/2021	52,215.04
ACH	06759	STATE OF CA - PR TAXES	01/28/2021	7,891.64
ACH	06760	STATE OF CA - SDI	01/28/2021	2,495.03
ACH	06761	LINCOLN FINANCIAL GROUP	01/28/2021	7,267.47
ACH	06763	PERS - PAYROLL	01/28/2021	36,487.08
ACH	91508	CALIFORNIA STATE DISBURSEMENT	01/28/2021	346.15
ACH	00152	FPUD EMPL ASSOCIATION	01/28/2021	24.50
ACH	06758	US TREASURY - PAYROLL TAXES	01/28/2021	3,140.20
ACH	06759	STATE OF CA - PR TAXES	01/28/2021	555.64
ACH	06760	STATE OF CA - SDI	01/28/2021	128.10
ACH	06761	LINCOLN FINANCIAL GROUP	01/28/2021	402.80
ACH	06763	PERS - PAYROLL	01/28/2021	1,924.19
85307	91499	FILANC ALBERICI A JOINT VENTURE	01/28/2021	2,916,917.09
85309	91500	US BANK NATIONAL ASSOCIATION	01/28/2021	153,521.42
85310	00101	ACWA JPIA	01/28/2021	107,925.89
85311	UB*00373	DAWN AGUERO	01/28/2021	4.06
85312	91286	AMAZON CAPITAL SERVICES, INC.	01/28/2021	145.14
85313	06536	ARCADIS U.S., INC	01/28/2021	8,155.50
85314	91487	BADGER METER, INC.	01/28/2021	7,479.33
85315	05958	BAMM! PROMOTIONAL PRODUCTS, I	01/28/2021	435.00
85316	06413	CALIFORNIA FARM BUREAU FEDERA	01/28/2021	325.00
85317	06141	CENTRISYS CORPORATION	01/28/2021	3,933.21
85318	91241	LISA CHAFFIN	01/28/2021	60.00
85319	06041	DEMSEY,FILLIGER & ASSOC, LLC	01/28/2021	500.00
85320	05192	DIAMOND ENVIRONMENTAL SERVIC	01/28/2021	225.90
85321	05987	FALLBROOK GARAGE & QWIK LUBE	01/28/2021	269.88
85322	00169	FALLBROOK OIL COMPANY	01/28/2021	1,510.58
85323	04494	FEDERAL EXPRESS CORPORATION	01/28/2021	55.56
85324	01432	FERGUSON WATERWORKS #1083	01/28/2021	4,496.68
85325	02170	GRAINGER, INC.	01/28/2021	909.42
85326	91572	GREEN GORILLA TREE SERVICE	01/28/2021	7,425.00
85327	05380	HACH CO	01/28/2021	676.84
85328	91544	HAZEN AND SAWYER, D.P.C.	01/28/2021	735.00
85329	06577	INFOSEND INC	01/28/2021	1,260.54
85330	06359	INFRASTRUCTURE ENGINEERING CO	01/28/2021	5,100.50
85331	04926	KONICA MINOLTA PREMIER FINANCE	01/28/2021	1,910.79
85332	06555	LIEBERT CASSIDY WHITMORE	01/28/2021	150.00
85333	91130	LINCOLN NATIONAL LIFE INSURANC	01/28/2021	3,191.31
85334	90887	LLOYD PEST CONTROL	01/28/2021	169.00
85335	91427	MITEL CLOUD SERVICES, INC	01/28/2021	320.70
85336	91561	MUNICIPAL SEWER TOOLS	01/28/2021	353.42
85337	04900	PARADISE CHEVROLET CADILLAC	01/28/2021	93.39
85338	91007	PFM ASSET MANGEMENT LLC	01/28/2021	930.79
85339	91426	PRINTING SOLUTIONS	01/28/2021	452.09
85340	91155	QUALITY GATE COMPANY, INC	01/28/2021	2,689.75
85341	06064	SOLENIS LLC	01/28/2021	10,430.36
85342	91223	STERLING ADMINISTRATION	01/28/2021	125.00

Check No	Vendor No	Vendor Name	Check Date	Check Amount
85343	91598	TCI BUSINESS CAPITAL	01/28/2021	3,358.32
85344	06228	TECHNOLOGY UNLIMITED INC.	01/28/2021	48.43
85345	91419	TEMECULA TROPHY & DESIGN	01/28/2021	26.10
85346	04330	UNION BANK	01/28/2021	1,146.00
Total for 1/28/2021:				3,364,180.83
Report Total (213 checks):				4,965,982.01



Jack Bebee

General Manager